

PIRANHA III

TUNGSTEN ELECTRODE GRINDER
SAFE • PRECISION • AFFORDABLE



HEAVY DUTY DEDICATED TUNGSTEN GRINDER
DESIGNED FOR CONTINUOUS GRINDING OF .040" TO 3/16" (1.0MM-4.8MM)

SAFETY: Enclosed grinding area captures Tungsten dust for easy disposal.

WELD QUALITY: 20 Ra surface finish improves Tungsten life, arc starting, arc stability and produces consistent weld penetration.

PRODUCTIVITY: Correctly and consistently Diamond grind your Tungsten Electrode longitudinally, in less than 30 seconds.

VALUE: The PIRANHA III Diamond grinds, flats and notches your Tungsten economically.

DIAMOND GROUND PRODUCTS

Visit our web site: www.diamondground.com



PIRANHHA III

Tungsten Electrode Grinder

FEATURES

- Continuous grinding of .040" - 3/16 (1.0 - 4.8mm) tungsten. Solid construction. No vibration.
- Longitudinal grinding for maximum arc stability.
- Precision scale for setup and repeatability.
- Electrode guide accommodates 6 electrode sizes.
- Capable of a wide range of included angles.
- Electrode notching station for simple cut-off.
- Electrode guide has square end grind position.
- Detailed Manual includes engineering data and welding recommendations.
- 6.0" diamond wheel improves your surface finish.

ADDITIONAL PRODUCTS

- **Piranhha II** - Compact/Precision tungsten grinder .040" - 1/8" (1.0 - 3.2mm).
- **DGP-II** - Full feature tungsten grinder that grinds, flats and precisely cuts the tungsten to a precise length.
- **Pre Ground Electrodes** - CNC manufactured high tolerance electrodes for Orbital and Automatic Tig and Plasma welding.
- **Premium Tungsten** - Thoriated, Lanthanated, Ceriated, Zirconiated, tri-mix, pure & specialty materials.

SPECIFICATIONS

Range of Included Angle.....10 to 60 degrees
Electrode Diameters......040", 1/16", 3/32", 1/8"
5/32", 3/16", (1.0, 1.6, 2.4, 3.2, 4.0, 4.8mm)
Minimum Electrode Length.....1.75" (44.0mm)
Voltage.....(100/120 VAC, 50/60Hz) 220v.
Power Consumption.....500 Watts
Dimensions
Length.....13.5" (342mm)
Width.....7.0" (177mm)
Height.....9.5" (240mm)
Weight.....38 lbs (83.6kg)

BENEFITS

- **Safety:** Enclosed grinding area captures Tungsten dust for easy disposal.
- **Weld Quality:** 20 Ra surface finish improves Tungsten life, arc starting, arc stability and produces consistent weld penetration.
- **Productivity:** Longitudinally Diamond grind your Tungsten electrode in less than 30 seconds correctly and consistently.
- **Value:** The PIRANHHA III Diamond grinds, flats and notches your Tungsten economically.

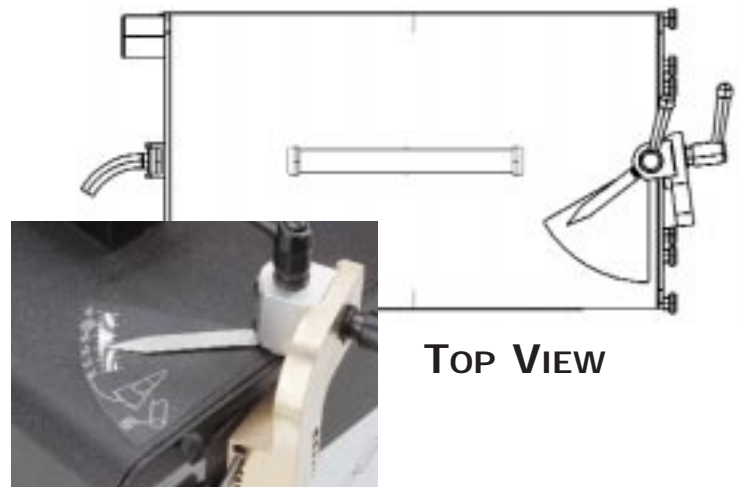
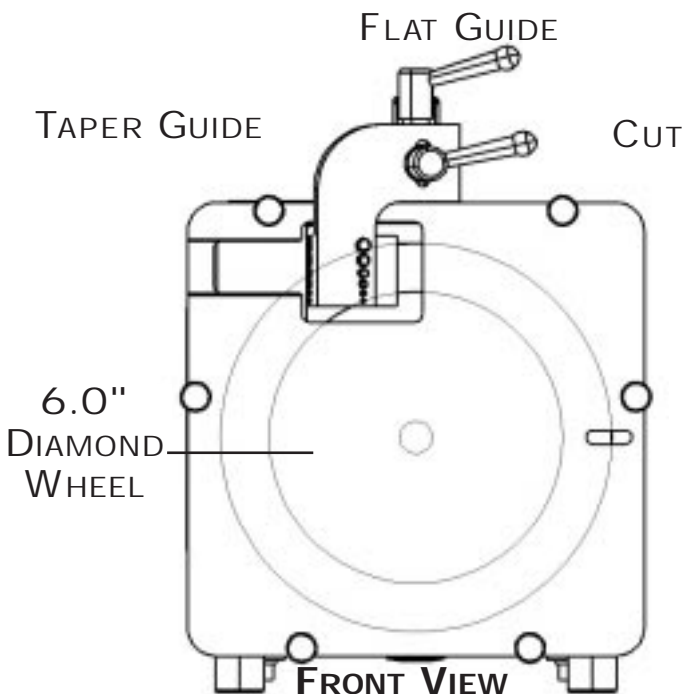

DIAMOND GROUND PRODUCTS, INC.

2550 Azurite Circle Newbury Park CA 91320

Phone (805) 498-3837 • FAX (805) 498-9347

Email: sales@diamondground.com

Visit our website: www.diamondground.com