



sheet
data

Compact 58° line laser diode module 650nm

Key features

- Visible light $\lambda = 650\text{nm}$
- Output powers 0.9mW, 4.0mW
- 58° line output
- 8mm diameter, 29mm length
- High reliability

Applications

- Industrial alignment
- Patient positioning

650nm Compact 58° Line Laser Diode Modules

The 650nm Compact Line Laser Diode Modules produce a 58° line output, with output powers of 0.9mW or 4.0mW. Operating voltage is from 3V to 6V DC at an operating current of 30mA typ (0.9mW) or 40mA typ.(4mW). Operating temperature range is -10°C to +40°C.

The modules consist of a brass housing, laser diode, drive circuit and line generating optics.

Electrical connections are made via external flying leads. The output is factory focused at 1m which provides a useable line up to 1500mm.

Focus can be set at other distances to order.

The Compact range of line laser diode modules has been designed as a complete laser diode solution for OEM use.

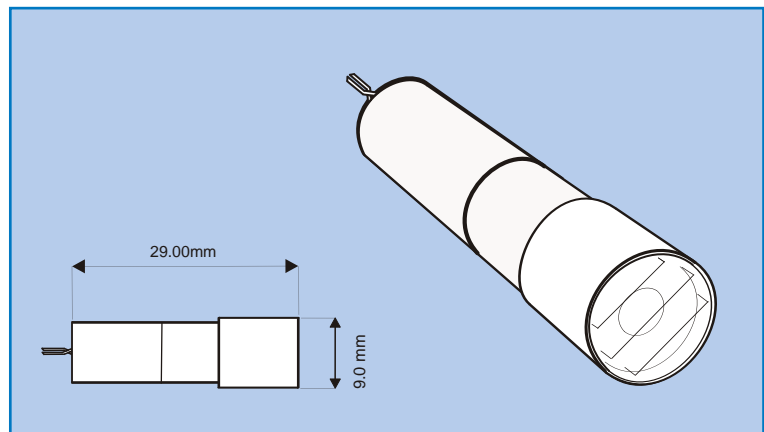

laser diode solutions



PHOTONIC
PRODUCTS

Compact 58° line laser diode module 650nm

Specifications (typical @ tc = 25°C)

Part no.	300-0228-00	300-0231-00
Wavelength	650nm typ., 660nm max	650nm typ., 660nm max
Output Power	0.9mW ±5% @ 25°C	4mW ±5% @ 25°C
Power Stability	< 5%	< 5%
Output Structure	line 58° full angle	line 58° full angle
Focus Distance (other distance can be set to order)	1m	1m
Operating Voltage (DC)	3.0-6.0V	3.0-6.0V
CW Operating Current	30mA typ., 45mA max	40mA typ., 50mA max
Operating Temperature (non-condensing)	-10°C to +40°C	-10°C to +40°C
Storage Temperature	-40°C to +85°C	-40°C to +85°C
Length	29mm	29mm
Diameter	8mm (9mm for lens cap)	8mm (9mm for lens cap)
Housing Material	Brass	Brass
Flying Lead Length	300mm	300mm
Circuit Protection	Static, Surge and Reverse Polarity Protected	

Heat Sinking

If the case temperature of the laser diode exceeds its maximum specification, premature or catastrophic failure may occur. To ensure the maximum life of the laser diode, it is recommended that an additional electrically insulated heatsink, of at least 35 sq.cm. be used. Thermal transfer cream can be used to improve contact and heat dissipation. Do not restrict air circulation around the device.

Power Connections

The Compact laser diode modules require a regulated input voltage of 3.0-6V DC. Connections are made via the 2 pre-tinned external flying leads, (red is positive, black is negative).

WARNING: The housing is internally connected to the positive supply rail.

Specifications subject to change without notice. E&OE

Laser Safety

The light emitted from these devices has been set in accordance with IEC60825. However, staring into the beam, whether directly or indirectly, must be avoided. IEC60825 classifies laser products into three different categories depending on light emitted, wavelength and eye safety.

CLASS II

"Caution", visible laser light less than 1.0mW. Considered eye safe, normal exposure to this type of beam will not cause permanent damage to the retina.

CLASS IIIR

"Danger", visible laser light between 1.0mW and 5.0mW. Considered eye safe with caution. Focusing of this light into the eye could cause some damage.

CLASS IIIB

"Danger", infrared (IR), and high power visible lasers considered dangerous to the retina if exposed.

NB: It is important to note that while complying with the above classifications, unless otherwise stated, our laser diode products are not certified and are designed solely for use in OEM products. The way in which the device is used in the final product may alter its original design classification, and it is the responsibility of the OEM to ensure compliance with the relevant standards.

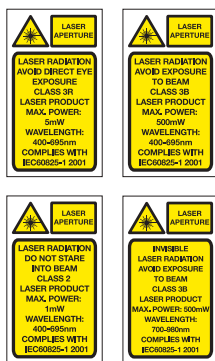

PHOTONIC PRODUCTS UK LIMITED

Pierce Williams, Sparrow Lane
Hatfield Broad Oak, Hertfordshire CM22 7BA UK
Telephone: +44 (0) 1279 717170
Facsimile: +44 (0) 1279 717171
E-mail: sales@photonic-products.com
www.photonic-products.com

PHOTONIC PRODUCTS USA

Telephone: +1 714-841-1960
E-mail: salesusa@photonic-products.com

PHOTONIC PRODUCTS GERMANY

Telefon: +49 (0) 8142 / 669 8364
E-mail: salesgermany@photonic-products.com
www.photonic-products.com



PHOTONIC
PRODUCTS