

A RANGE OF TOP QUALITY MOBILE AND STATIC VESSELS WITH CAPACITIES FROM 30 TO 2,000 LITRES



#### PHARMAVESSEL INTRODUCTION

Suncombe PharmaVessels provide a total solution for liquid mixing and storage in the high quality processing industries.

PharmaVessels can be supplied from our standard range — comprising the most commonly requested mobile and static vessels with a choice of optional extras — or in bespoke configurations with your choice of equipment options. Standard or custom-built, PharmaVessels are available either as pressure or atmospheric vessels.

PharmaVessels are one element of the Suncombe product range, which incorporates high quality, economically priced tanks, vessels, mixers and processors with capacities from 10 to 10,000 litres. With over 40 years' experience in the field, Suncombe has a firmly-established reputation for the high quality and durability of its equipment.

#### TYPICAL INDUSTRIES

Biotech, Pharmaceutical, Medical, Healthcare, Personal Care and other critical processing industries.

#### INTEGRATED SYSTEMS

PharmaVessels are easily integrated into complete process systems. Suncombe offers integration services including process evaluation, PFD and P&ID development, plant layout, detail design, critical path analysis, equipment construction, procurement of ancillaries, installation/commissioning, documentation and validation, training — operation and maintenance.

#### EQUIPMENT STANDARDS

Process standard (180 grit) or Purified Water Handling standard ( $\leq 0.4$  mmRa surface finishes).  $\leq 0.1$  mmRa and electropolished finishes available.

#### CLEANING PROFILE

Suncombe PharmaVessels are supplied with a computer-generated simulation of the cleaning pattern for the internals of the vessel. This provides confirmation of the cleanability of the vessels and can be used for validation purposes.

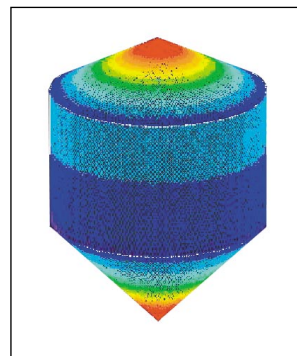

*Typical  
spray  
pattern*

#### COMPLEMENTARY CLEANING SYSTEMS

Suncombe manufactures a range of systems suitable for cleaning PharmaVessels. These include static and mobile CIP systems — JetCIP25 and 50, Mobile CIP, PharmaCIP and VICIP — UltraWasher cabinet cleaners, SIP and drying systems.

# SUNCOMBE PHARMAVESSELS

## FEATURES

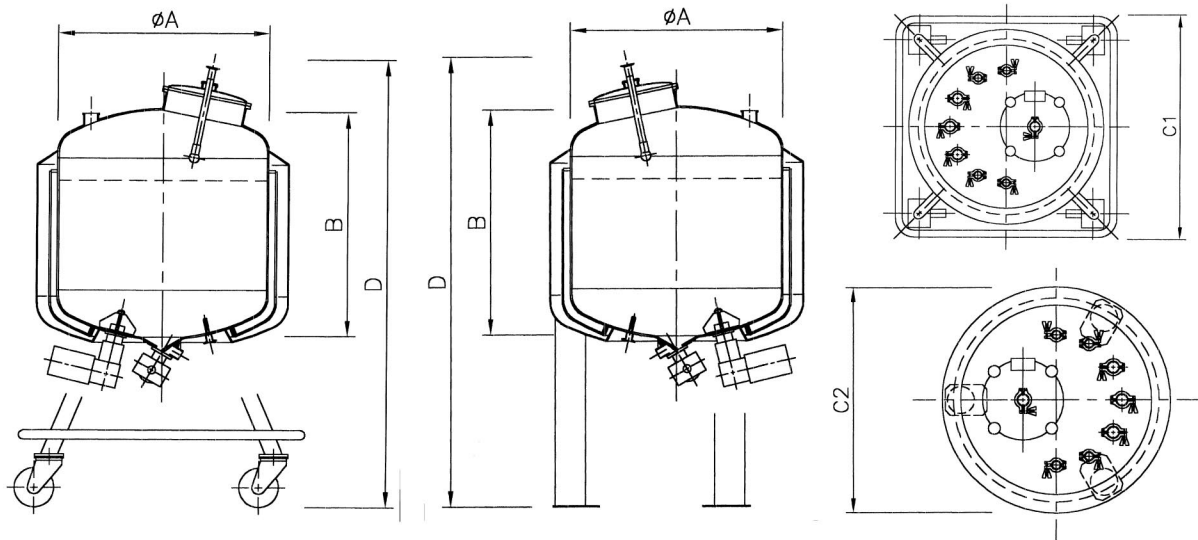

Volume litres	ØA mm	B mm	C1 mm	C2 mm	D mm
30	412	450	600	560	1100
40	412	525	600	560	1150
50	450	600	700	600	1200
60	450	650	700	600	1250
100	550	700	800	700	1350
150	600	800	850	750	1450
250	800	850	1100	950	1700
300	800	1000	1100	950	1800
500	1000	1075	1250	1150	1850
600	1000	1250	1250	1150	2000
750	1000	1450	x	1150	2200
1000	1100	1500	x	1250	2250
1500	1250	1650	x	1400	2400
2000	1400	1875	x	1550	2550

### STANDARD FEATURES

PharmaVessels are available in the following sizes (capacity in litres): 30, 40, 50, 60, 100, 125, 150, 200, 250, 500, 750, 1000, 1250, 1500 and 2000 litres. Other volumes on request.

### OPTIONAL EXTRAS

- Top and bottom entry mixers/homogenisers
- Remote operator interfaces
- Interface to product and CIP/SIP equipment
- CIP spray devices
- Data logging and control via SCADA package
- Ex-rated and zoned versions
- Installation
- Service panels/flowplates
- Networked control systems
- Special construction
- Temperature control
- Heat exchangers
- Automatic PLC control
- Colour touch panel operator interface
- Full validation package
- Jacket control and relief devices with burst discs
- Limpet coils
- Stainless steel platforms
- Discharge pumps
- Vacuum pumps
- Powder incorporation hoppers
- Other process sensors
- Third party inspection by Lloyds or nominated agency
- Full design service
- Free lifetime telephone support