



## Features

- Load-lock sample exchange capabilities
- High stability operation from 10 K to 400 K
- Active cryogenic control of the cold head and radiation shield
- Measurements from DC to 67 GHz
- Top load accommodates up to 51 mm (2 in) diameter wafers; up to 12.7 mm (0.5 in) diameter wafers using load-lock
- Configurable with up to six micro-manipulated probe arms
- Probe arms with 3-axis adjustments and  $\pm 5^\circ$  theta planarization
- Sample stage with  $\pm 5^\circ$  in-plane rotation
- Cables, shields, and guards minimize electrical noise and thermal radiation losses
- High resolution optical system
- Options and accessories for customization to specific research needs

## Model LLTTP6 Probe Station

### Introduction

The Model LLTTP6 is a versatile, load-lock cryogenic micro-manipulated probe station. It is used for non-destructive testing of devices on full and partial wafers up to 51 mm (2 in) in diameter when top loaded, or 12.7 mm (0.5 in) in diameter using the load-lock assembly. The LLTTP6 is a platform for the measurement of electrical, electro-optical, parametric, high Z, DC, RF, and microwave properties of materials and test devices. Nanoscale electronics, quantum wires and dots, and semiconductors are typical materials measured in a LLTTP6. A wide selection of probes, cables, sample holders, and options makes it possible to configure the LLTTP6 to meet your specific measurement applications.

The LLTTP6's load-lock capability allows sample exchange without warming the vacuum chamber or breaking vacuum, significantly improving efficiency and throughput by reducing cycle time to roughly one hour. Load-lock also allows samples to be exchanged under controlled environmental conditions.

The LLTTP6 operates over a temperature range of 10 K to 400 K, and provides efficient temperature operation and control with a continuous refrigeration system using either helium or nitrogen. Vapor-cooled shielding optimizes efficiency and intercepts blackbody radiation before it reaches the sample. Two control heaters on the cold head minimize temperature gradients across the sample and, along with the radiation shield heater, provide the probe station with fast thermal response.

The LLTTP6 is user configured with up to six ultra-stable micro-manipulated probe arms. Each arm provides precise 3-axis control of the probe position to accurately land the probe tip on device features. The sample stage provides in-plane rotation to allow alignment of patterns with stage axes. Proprietary probe tips in a variety of sizes and materials minimize thermal mass and optimize electrical contacts to the device under test (DUT). Probe tips are thermally linked to the cold head to minimize heat transfer to the DUT.

For increased versatility, LLTTP6 options include vibration isolation systems, LN<sub>2</sub> Dewar kit, higher magnification monoscopes, vacuum turbo pumping system, and probe arm fiber optic cable.

### Headquarters and Sales

Lake Shore Cryotronics, Inc.

575 McCorkle Boulevard ■ Westerville, Ohio 43082

Phone 614-891-2244 ■ Fax 614-818-1600

[info@lakeshore.com](mailto:info@lakeshore.com) [www.lakeshore.com](http://www.lakeshore.com)

All specifications subject to change. Rev 7/6/2006

## Applications

- Sample exchange under vacuum and controlled environmental conditions
- Electrical and electro-optical measurements over a wide temperature range
- RF and microwave
- Parametric testing
- Shielded/guarded/low noise characterization
- High Z
- Non-destructive, full wafer testing

## Materials

- Nanoscale electronics (carbon nanotube transistors, single electron transistors, molecular electronics, nanowires, etc.)
- Quantum wires and dots, quantum tunneling
- Single electron tunneling (Coulomb blockade)
- Basic semiconductor devices including organics, LEDs, and dilute magnetic semiconductors

## Specifications

### Temperature

<b>Operating temperature range—all probe types</b>	10 K to 400 K
<b>Temperature control (heaters)</b>	
Cold head	50 W (2 parallel heaters, 25 W each)
Two radiation shields	100 W and 50 W
Probe arm	Measurement only

### Probe Arm and Sample Stage Adjustments

<b>Travel</b>	
X axis	51 mm (2 in)
Y axis	25 mm (1 in)
Z axis	18 mm (0.7 in)
<b>Translation resolution</b>	
X axis	20 $\mu$ m
Y and Z axes	10 $\mu$ m
Theta planarization*	$\pm 5^\circ$
<b>Sample stage (sample holder) in-plane rotation</b>	$\pm 5^\circ$

\* Included with microwave probes

## Frequency Range

<b>ZN50 DC/RF probe frequency range</b>	
Tungsten with cryogenic coax cable	0 to 50 MHz*
Tungsten with semirigid coax cable	0 to 1 GHz* <sup>†</sup>
Paliney 7 with cryogenic coax cable	0 to 50 MHz*
Paliney 7 with semirigid coax cable	0 to 1 GHz* <sup>†</sup>
BeCu with cryogenic coax cable	0 to 50 MHz*
BeCu with semirigid coax cable	0 to 1 GHz* <sup>†</sup>
<b>GSG microwave probe frequency range</b>	
Low frequency with K connector	0 to 40 GHz*
Mid frequency with 2.4 mm connector	0 to 50 GHz*
High frequency with 1.8 mm connector	0 to 67 GHz*

\*Selectable equipment

<sup>†</sup> S21 > -10 dB up to 1 GHz, except for a (-40 dB) spike between 400 MHz and 800 MHz depending on probe model and placement; S11 < -3 dB up to 1 GHz

## Optical

<b>Optical viewport—located on top lids</b>	Ø54 mm (2.1 in) outer window and Ø51 mm (2 in) inner window
Outer, clear fused quartz	99% IR transmittance
Inner	IR absorbing with narrow band visible light transmittance
<b>Optical resolution—monoscope</b>	
7:1 zoom	5 µm
12.5:1 zoom	4 µm*
16:1 zoom	3 µm*

\*Selectable equipment

## Sample Holder (Chuck)

<b>Maximum sample size—overall</b>	Up to Ø51 mm (2 in)
SH-0.50-G, Grounded chuck	Up to Ø12.7 mm (0.5 in) and 400 K
SH-1.25-G, Grounded chuck	Up to Ø31.8 mm (1.25 in) and 400 K*
SH-1.25-I, Isolated chuck	Up to Ø31.8 mm (1.25 in) and 400 K*
SH-1.25-C, Coaxial chuck	Up to Ø31.8 mm (1.25 in) and 400 K*
SH-1.25-T, Triaxial chuck	Up to Ø31.8 mm (1.25 in) and 400 K*
SH-2.00-G, Grounded chuck	Up to Ø51 mm (2 in) and 400 K*
SH-2.00-C, Coaxial chuck	Up to Ø51 mm (2 in) and 400 K*
SH-2.00-T, Triaxial chuck	Up to Ø51 mm (2 in) and 400 K*

\*Selectable equipment – cannot be used in combination with load-lock assembly

## Standard Equipment

<b>Open cycle multi-stage refrigerator</b>	10 K to 400 K
<b>Cold head stage temperature sensor</b>	Lake Shore Model DT-670-SD-1.4H calibrated silicon diode
<b>Cold head stage heater</b>	50 W (2 parallel heaters, 25 W each)
<b>Cooled radiation shield and cooled IR-absorbing window above the sample</b>	
<b>Two radiation shield temperature sensors</b>	Lake Shore Model DT-670C-CU silicon diode
<b>Two radiation shield heaters</b>	100 W and 50 W
<b>Removable top lid with viewport</b>	Ø51 mm (2 in) window
<b>Temperature controllers</b>	Two Lake Shore Model 332Ss and one Model 142 200 W (2 channels, 100 W each) power supply (independent regulation of cold head stage, radiation shield, and probe arm temperature monitoring)
<b>Vacuum chamber</b>	
<b>Diameter</b>	25.4 cm (10 in)
<b>Removable top lid with clear fused quartz viewport</b>	Ø54 mm (2.1 in) window
<b>Probe ports</b>	6 surround the sample thermal radiation shield
<b>Machined aluminum base plate</b>	66.0 × 53.3 cm (26 × 21 in)
<b>Vibration isolation table</b>	Low vibration, non-magnetic stand, PVC construction with sand-weighted legs and brass fittings
<b>Six XYZ precision micro-manipulated probing stages</b>	
<b>Probe arms, thermal radiation shields, stainless steel welded bellows, and feedthrough ports</b>	
<b>Thermally linked probe mounts</b>	Probe mounts and radiation shield are thermally anchored to the cold head; one probe mount includes a platinum temperature sensor installed and wired to a 6-pin feedthrough
<b>Grounded sample holder</b>	SH-0.50-G, accommodates up to a Ø12.7 mm (0.5 in) sample with a Ø12.7 mm (0.5 in) probe area
<b>Optics</b>	
<b>Zoom 70 monoscope</b>	7:1 zoom with 5 µm resolution
<b>Color CCD camera</b>	
<b>Swing arm</b>	Optics can be manipulated to view any part of the sample or wafer, and can be retracted and swung away to allow access to the top of the vacuum chamber for sample exchange
<b>Video monitor</b>	High resolution, 17-inch
<b>Sample illumination</b>	Coaxial via fiber optic from an adjustable light source and power supply <b>NOTE: The PS-RL ring light option is recommended for highly reflective materials</b>
<b>High efficiency helium transfer line with foot valve for precise flow regulation</b>	
<b>Basic tools, spares, and cleaning kit</b>	

## Probes, Probe Tips, and Cables — Required User Configurable Equipment

### ZN50 DC/RF PROBES

- Ideal for: DC biasing, low/high frequency measurements, low noise shielded, and low-leakage guarded measurement
- ZN50 probe base incorporates a pair of copper braids that connect to the sample stage to dynamically cool/heat the probe to the sample temperature
- SMA connector mounted directly to a replaceable alumina ceramic blade with a 50 Ω stripline routed to the probe contact

We understand that today's researcher requires flexibility. Our wide selection of probes, cables, sample holders, and options make it possible to configure a probe station to meet your specific measurement applications.

Part number (probe body)	Description
ZN50-26U	50 Ω stripline probe body mount (each probe body mount requires a ceramic blade—selectable below)

Part number (ceramic blade)	Tip material	Maximum frequency (GHz)	Tip radius (μm)
ZN50R-03-W	Tungsten	1*	3
ZN50R-10-W			10
ZN50R-25-W			25
ZN50R-03-P7	Paliney 7		3
ZN50R-10-P7			10
ZN50R-25-P7			25
ZN50R-03-BeCu	BeCu		3
ZN50R-10-BeCu			10
ZN50R-25-BeCu			25
ZN50R-100-BeCu			100
ZN50R-200-BeCu			200

\*Maximum frequency 50 MHz with Z50-CU-SS-3650-G or Z50-CU-SS-3650-T cable; maximum frequency 1 GHz with K-085-K cable

### ZN50 DC/RF CABLES

Part number	Cable type	Connector type	Feedthrough type	Measurement configuration	Maximum frequency	Maximum temperature
Z50-CU-SS-3650-G	Ultra-miniature cryogenic coax	SMA	BNC	Shielded	50 MHz	400 K
Z50-CU-SS-3650-T	Ultra-miniature cryogenic coax	SMA	2-lug triax	Low leakage	50 MHz	400 K
K-085-K-09	Stainless semirigid microwave coax	K	Loss-less compression seal	High frequency	1 GHz*	400 K

\* S21 > -10 dB up to 1 GHz, except for a (-40 dB) spike between 400 MHz and 800 MHz depending on probe model and placement; S11 < -3 dB up to 1 GHz

### GSG MICROWAVE PROBES

- Coplanar waveguide probe with ground-signal-ground (GSG) contact geometry
- User-specified pitch (spacing)
- Optimized low thermal conductivity coax leading to low thermal conductivity tips
- Include a copper braid assembly to cool the probe to near sample temperature
- Separate theta planarization module with  $\pm 5^\circ$  rotation mechanism is also provided

Part number	Connector type	Maximum frequency (GHz)	Pitch ( $\mu\text{m}$ )
GSG-050-40A-26U-D	K	40	50
GSG-100-40A-26U-D			100
GSG-150-40A-26U-D			150
GSG-200-40A-26U-D			200
GSG-250-40A-26U-D			250
GSG-050-50A-26U-D	2.4 mm	50	50
GSG-100-50A-26U-D			100
GSG-150-50A-26U-D			150
GSG-200-50A-26U-D			200
GSG-250-50A-26U-D			250
GSG-050-67A-26U-D	1.8 mm	67	50
GSG-100-67A-26U-D			100
GSG-150-67A-26U-D			150
GSG-200-67A-26U-D			200
GSG-250-67A-26U-D			250

### GSG MICROWAVE CABLES

- Loss-less compression seal
- Semirigid with stainless steel outer jacket, silver plated BeCu inner conductor, and Teflon® dielectric

Part number	Cable type	Feedthrough type	Maximum temperature	Connector type	Maximum frequency
K-085-K-09	Stainless semirigid microwave coax	Loss-less compression seal	400 K	K	40 GHz
2.4-085-2.4-09				2.4 mm	50 GHz
1.8-085-1.85-09				1.8 mm	67 GHz

### SAMPLE HOLDERS (CHUCKS)

Typical sample holder configuration characterized by:

- Leakage resistance between
  - Top surface and guard
  - Guard and ground
- Capacitance between
  - Top surface and guard
  - Guard and ground

### Types of sample holders

- Grounded sample holder—sample mount surface at system ground
- Isolated sample holder—backside contact not needed; sample mount surface is electrically non-conductive and isolated from ground
- Coaxial sample holder—backside contact can be made; sample mount surface is isolated from ground
- Triaxial sample holder—guarded backside contact can be made; sample mount surface has guarded isolation from ground

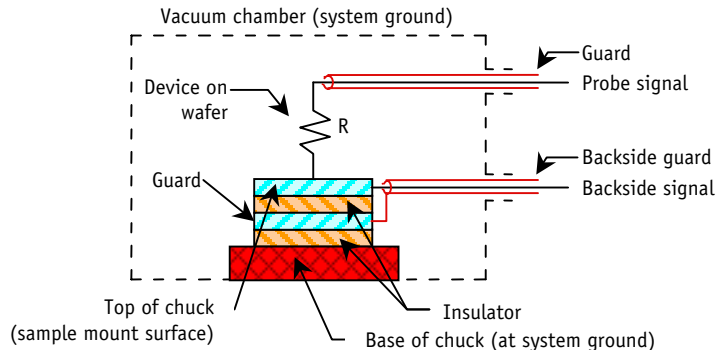

Part number	Measurement configuration	Separate feedthrough required	Maximum sample (diameter)	Maximum temperature
SH-0.50-G	Grounded	No	Ø12.7 mm (0.5 in)	400 K
SH-1.25-G	Grounded			
SH-1.25-I	Isolated	Yes*	Ø31.8 mm (1.25 in)***	
SH-1.25-C	Coaxial			
SH-1.25-T	Triaxial			
SH-2.00-G	Grounded	No	Ø51 mm (2 in)***	
SH-2.00-C	Coaxial	Yes*		
SH-2.00-T	Triaxial	Yes**		

\*Coaxial sample holders require one FT-BNC or FT-TRIAX feedthrough as listed below

\*\*Triaxial sample holders require one FT-TRIAX feedthrough as listed below

\*\*\*Cannot be used in combination with load-lock assembly

Part Number	Description
FT-BNC	Coaxial feedthrough and coax cable, installed and wired
FT-TRIAX	Triaxial feedthrough and coax cable, installed and wired

### Equipment Options

Part number	Description
PS-FOA	Fiber optic probe arm modification. Transmit or receive light or IR/UV radiation. Fiber optic terminated with SMA connector or compression feedthrough. (Fiber optic wire not included. Fiber optic and probe cannot be used simultaneously.)
PS-RL	Ring-lit sample illumination—includes ring light and fiber optic— <b>recommended for highly reflective materials</b>
PS-Z12.5	12.5:1 zoom monoscope upgrade for 4 µm resolution NOTE: upgrade is not field-installable
PS-Z16	16:1 zoom monoscope upgrade for 3 µm resolution NOTE: upgrade is not field-installable
PS-DPC	Automatic Dewar (gas) pressure controller, regulates Dewar liquid flow
PS-V70TP	Turbo pumping system—includes Varian V-70 Turbo Pump cart with DS 102 backing pump, vacuum gauging for high vacuum and fore line, controller, and adaptors (specify 110 V/60 Hz or 220 V/50 Hz)
PS-V70DP	Turbo pumping system. Includes Varian V-70 Turbo Pump cart with oil free backing pump, vacuum gauging for high vacuum and fore line, controller, and adaptors (specify 110 V/60 Hz or 220 V/50 Hz)

## Equipment Options, continued

Part Number	Description
PS-LN2	Nitrogen Dewar with stainless fittings, gauges, and adaptors; allows LN <sub>2</sub> use with the LHe transfer line
PS-PLVI-25	Pump-line vibration isolator—includes NW-25 fittings, 1 m stainless steel bellows, clamps, and rings (placed between pump cart and system); requires one bag of cement
PS-TTVIS	Pneumatic tabletop vibration isolation system—compact pneumatic isolator with self-leveling (isolator resonance: vertical 3.2 Hz, horizontal 3.6 Hz; isolation efficiency at 10 Hz: vertical 90%, horizontal 96%; amplification at resonance: vertical 12 dB, horizontal 10 dB); 80 psi nitrogen or air
PS-OAC	Oil-less compressor for PS-TTVIS or PS-TMC-B (only available in 110 V)
PA-SEN	Probe arm modification with platinum temperature sensor installed and wired to a 6-pin feedthrough
PA-LLTTP6	Probe arm and base for LLTTP6
MMS-LLTTP6	Micro-manipulated stage for LLTTP6
CS-5	Calibration substrate for GSG probes. Pad size: 50 μm <sup>2</sup> ; calibration type: SOLT (short-open-load-through), LRL (line-reflective-line), LRM (line-reflective-match); pitch range: 75 to 250 μm

A division of Lake Shore Cryotronics, Desert Cryogenics is a leading supplier of cryogenic, superconducting magnet-based, electromagnet-based, high vacuum, and load-lock probe stations. We offer a full line of standard probe stations to meet your specific research requirements.

### *Our standard line of probe stations includes:*

#### **Model TTP4**

- Up to four micro-manipulated probe stages
- Temperature range capabilities from 3 K to 475 K
- Up to 51 mm (2 in) diameter wafer capabilities

#### **Model TTP4-1.5K**

- Up to four micro-manipulated probe stages
- Standard temperature range from 1.5 K to 475 K
- Up to 25 mm (1 in) diameter wafer capabilities

#### **Model TTP6**

- Up to six micro-manipulated probe stages
- Temperature range capabilities from 3 K to 475 K
- Up to 51 mm (2 in) diameter wafer capabilities

#### **Model FWP6**

- Up to six micro-manipulated probe stages
- Standard temperature range from 4.5 K to 475 K
- Up to 10.2 cm (4 in) diameter wafer capabilities

#### **Model LLTTP6**

- Load-lock — for fast sample exchange at any temperature
- Up to six micro-manipulated probe stages
- Standard temperature range from 10 K to 400 K
- Up to 51 mm (2 in) diameter wafer capabilities; up to 12.7 mm (0.5 in) with load-lock assembly

#### **Model HFTTP4**

- 1 T horizontal field split pair superconducting magnet
- Up to four micro-manipulated probe stages
- Temperature range capabilities from 2 K to 400 K with field on or off
- Up to 25 mm (1 in) diameter wafer capabilities

#### **Model VFTTP4**

- 2.5 T vertical field solenoid superconducting magnet
- Up to four micro-manipulated probe stages
- Temperature range capabilities from 2 K to 400 K with field on or off
- Up to 51 mm (2 in) diameter wafer capabilities

#### **Model EMTP4 — Coming Soon**

- 0.55 T horizontal (in-plane field) electromagnet
- Up to four micro-manipulated probe stages
- Standard temperature range from 10 K to 450 K
- Up to 25.4 mm (1 in) diameter wafer capabilities

#### **Model HVTP6**

- High vacuum to 10<sup>-7</sup> torr
- Up to six micro-manipulated probe stages
- Temperature range capabilities from 2 K to 475 K
- Up to 51 mm (2 in) diameter wafer capabilities