

## Ronningen-Petter™ DCF-800



## Mechanically Cleaned Filter System

The DCF-800 disc clean filter (DCF) is an innovative, proven solution for filtering a wide range of liquids in a wide range of applications.

Designed to address the challenges of increasing environmental costs and pressures, loss of valuable product, and the need for greater operator safety, the DCF-800 is like no other filtration system on the market. Key benefits include:

- No loss of valuable product caused by media changeout
- No replacement media costs or disposal needs
- Mechanically cleaned permanent media
- Reduced operator exposure
- Reduced environmental impact
- Reduced labor demands – no more media changeouts
- Increased profitability – improves overall system efficiency and reduces downtime
- Longer life – high screen strength and erosion resistance
- Space-saving design – small, compact footprint
- Collection and removal of contaminant from fluid being filtered – with no interruption of operation
- Unattended operation capability – with optional automation packages

### How the DCF-800 works

The patented design uses a spring-loaded cleaning disc that travels up and down inside the filter media – removing collected contaminants. Filtrate flows from the top down and from the inside of the media outward to increase retention of undesirable solids. Contaminants are trapped on the screen for easy removal and evacuation to the purge collection chamber.

On the downstroke, any remaining contaminants are driven downward. This process concentrates the solids for easy, complete elimination through the purge chamber.



On the upstroke, the cleaning disc removes particles from the media surface. System fluid flow washes the particles downward toward the purge chamber past the cleaning disc.



**RPA Process Technologies**

Ronningen-Petter • Aoustin • Filtrés Philippe • Filtrés Vernay • Malaxeurs Guittard

**Industrial liquid filtration,  
separation and mixing solutions**

# Ronningen-Petter DCF-800

## Mechanically Cleaned Filter System

# Product Specifications

### Dimensions

Weight: 75 lbs (34 kg)  
Height: 51.3 in. (1,303 mm)  
Service: 69.3" in. (1,760 mm)  
Footprint: 15.8 in. (402 mm) x  
15.8 in. (402 mm)  
Volume: 3.9 gal (15 l) total  
Debris Volume: 25 fl. oz. (.74 l)  
capacity

### Connection

Standard: 2 in. (50 mm) I/O NPT thread, 1.5 in. (40 mm) purge valve NPTI thread  
Optional: Flanged (ANSI, DIN), tri-clamp or BST thread

### Process Parameters

Temperature: 400°F (204°C) max.  
Flow: 10–60 gpm (40-230 l/min)  
Operating pressure: 30–150 psig (2–10.5 bar)

### Media

Wedge wire: 15 $\mu$  – 1125 $\mu$ , or defined pore 25 $\mu$  – 100 $\mu$   
Screen: diameter 7 in. (178 mm), length 12 in. (305 mm), area 264in<sup>2</sup> (1,703 cm<sup>2</sup>)

### Elastomer Seals

Standard:

Element and lid: Viton® (400°F (204°C) maximum),  
Shaft seal: urethane (220°F (105°C) maximum)

Optional:

Element and lid: EPT (300°F (149°C) maximum), or Teflon® 400°F (204°C) maximum  
Shaft seal: Teflon (400°F (204°C) maximum)

### Cleaning Disc

Standard: Polyethylene (UHMWPE) (180°F/82°C)  
Optional: Teflon (400°F/204°C)  
Kynar (285°F/140°C)

### Housing/Wetted Parts Materials

Standard: 316 stainless steel, glass bead blasted

### Stand Materials

Standard: painted carbon steel  
Options: 304 stainless steel

### Controllers

Standard: continuous cleaning valve (CCV)  
Options: push button, semi-automatic electric, electric timer, single pneumatic timer, dual pneumatic timer, PLC minicomputer

### Utilities

Electrical: (if equipped with optional electrical automatic control timer): 110 or 220 Volt, 50 or 60 Hz, single-phase.

Air: 60 psig (4 bar) at 5 CFM (140 m<sup>3</sup>/m). Air must be clean, dry, and non-lubricated

Water:

when equipped with optional FluidSeal: flow rate <1 gpm (3.8 l/min)  
when using water (rather than filtrate) with optional Stealth Purge: 35 psig (2.4 bar) or less than filter's inlet pressure

### FluidSeal Option

Advanced dual seal design replaces standard single seal. Available in Teflon or urethane to suit liquid properties. With Twin Actuators, also available as a retrofit kit.

### Other Options

Twin actuators – retrofit kit available  
Stealth Purge with semi-automatic or PLC mini computer – water flush available

Steam jacketed housing  
ASME UM code

Electropolish external/internal  
Polished internal surface finish  
1/4in. (6.4 mm) NPTI gauge ports  
Multiplex configuration

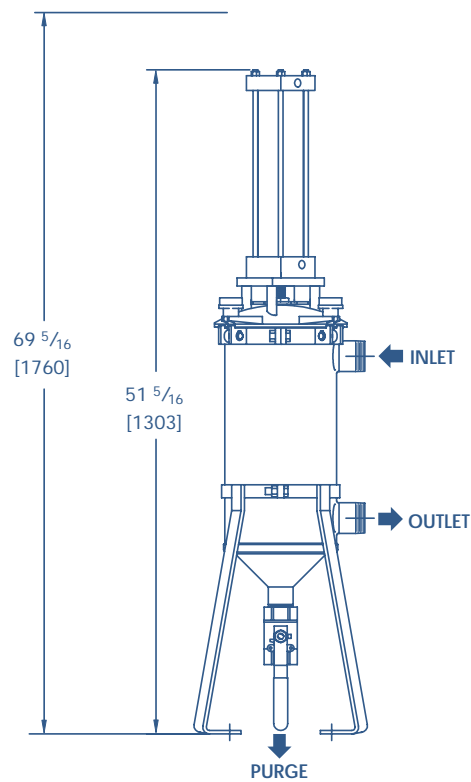

RPA Process Technologies  
9151 Shaver Road  
P.O. Box 188  
Portage, Michigan 49081-0188 USA  
Toll Free: 800-656-3344 (North America only)  
Phone: +1 616-323-1313  
Fax: +1 616-323-0065  
E-mail: info@RPAprocess.com  
Web: www.RPAprocess.com

RPA Process Technologies SAS  
Immeuble Colisée Défense  
50-64 avenue François Arago  
F-92022 Nanterre Cedex France  
Phone: +33 (0)1 56 83 83 00  
Fax: +33 (0)1 56 83 83 01

RPA Process Technologies reserves the right to change specifications without prior notice.

DCF is a registered trademark and FluidSeal is a trademark of RPA Process Technologies. All other trademarks are the properties of their respective owners.

©2002 RPA Process Technologies  
RPA-DCF800SS  
PWB RPF-140 02/02 4M  
Litho in U.S.A.



**RPA Process Technologies**

Ronningen-Petter • Aoustin • Filtres Philippe • Filtres Vernay • Malaxeurs Guittard