

Lightweight Waveguide Switches

WR62, WR75, WR90

| | |
|--------------------|--------------------|
| WR62T1-4321 | WR62T2-4321 |
| WR75T1-4321 | WR75T2-4321 |
| WR90T1-4321 | WR90T2-4321 |

Description

Dow-Key latching Lightweight Waveguide Switches are superior to previous designs in terms of weight, size, and current consumption. In addition, these switches are equipped with Indicator Circuitry and with Transient Suppression Diodes.

The total weight for the WR62 has been reduced by 46% and by 55% for both WR75 and WR90 waveguide models. The overall dimensions are slightly smaller when compared to earlier Dow-Key designs and they draw 65% less current.

These waveguide switches are excellent for use in all types of applications where size and weight are critical in such as military and commercial airborne programs. For Space Qualified requirements consult with factory for our Hi-Rel Waveguide Switch product line, ranging in sizes from WR15 to WR112.

Frequency Ranges

| | |
|--------------|---------------|
| WR62Tx*-4321 | 12.4-18.0 GHz |
| WR75Tx*-4321 | 10.0-15.0 GHz |
| WR90Tx*-4321 | 8.2-12.4 GHz |

* Available Flange Types: T1 = Cover Flange T2 = Choke Flange

RF Characteristics

| | |
|----------------------|---------|
| VSWR (max) | 1.10:1 |
| Insertion Loss (max) | 0.10 dB |
| Isolation (min) | 60 dB |

Actuation Data

| | |
|-----------------------------|-----------------------|
| Operating Voltage (range) | 24-30 Vdc |
| Operating Voltage (nominal) | +28 Vdc |
| Operating Current (max) * | 0.35 A |
| Switching Time (max) | 100 ms |
| Operating Mode | Latching Self Cut-Off |

* At +28 Vdc and 20 °C

Mechanical

| | |
|--------------|---------------------|
| Weight (max) | 300 gram (10.6 oz.) |
| Design Life | 200,000 Cycles |



WR90T2-4321

Materials and Finishes

| | |
|----------------------|------------------------------|
| RF Waveguide Housing | Aluminum, Chem Film |
| Actuator Housing | Aluminum, Electroless Nickel |

Environmental

| | |
|-----------------------|------------------|
| Operating Temperature | -54 °C to +85 °C |
| Storage Temperature | -54 °C to +85 °C |

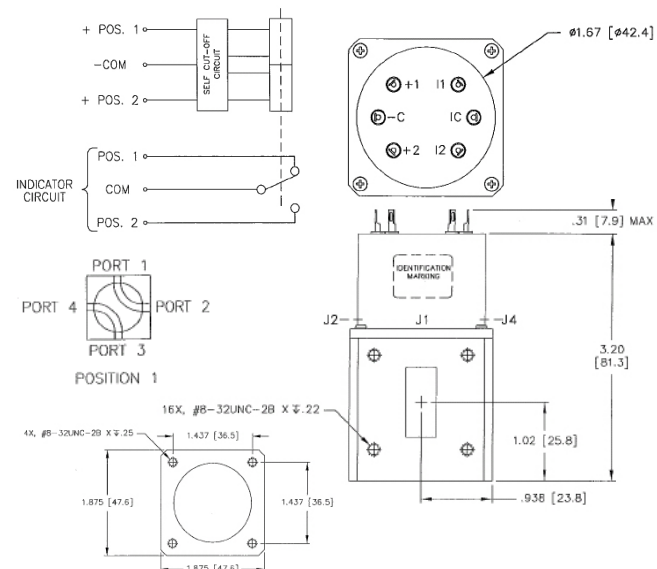

Microwave Products

4822 McGrath Street, Ventura, CA 93003
 Tel: (805) 650-0260 Fax: (805) 650-1734
 Visit us at www.dowkey.com