



PIC32™ Industrial Host Microcontroller for StackableUSB™ USB1032



Features

- ✓ 80MHz System Clock
- ✓ 1.56 DMIPS/MHz Performance
- ✓ 512KB Flash, 32KB SRAM Memory
- ✓ Single-Cycle Multiply and High-Performance Divide Unit
- ✓ Onboard RS232 Transceiver
- ✓ Easy Development with Microchip's MPLAB IDE
- ✓ Small 1.85" x 1.78" board
- ✓ -40° to +85°C operation



The USB1032 is the ideal module for applications requiring more performance than typical micro-controllers have offered but not needing the full blast offered by an SBC. Well-suited for applications confined to small, tight spaces, the 125 DMIPS performance requires only 100mA power, considerably less than an SBC.

The USB1032 is powered by the PIC32 microcontroller whose USB 2.0 On-The-Go (OTG) functionality allows the microcontroller to be used as a Host. Operating as a Host device, design engineers can easily and cost-effectively stack StackableUSB client I/O devices onto the controller making a small, embedded controller ideally suited to harsh environments.

Available onboard is a host of control features including 10-bit ADC, COM1, 8 programmable LEDs, and digital I/O. Developers will appreciate the PIC32's easy-to-use and solidly-supported software tools as they program and debug.

The 1.85" x 1.78" module is USB 2.0 compliant providing users the advantages of plug-and-play interfacing. The module stacks onto the top or bottom of any StackableUSB client single board computer or microcontroller forming a small, rugged, embeddable system, ideal for harsh environments. The USB1032 can be connected to desktop PCs and laptops via a Type B mini-USB connector for development.

Software/Driver Support

- Windows XP, Vista
- MPLAB IDE
- MPLAB C32 C Compiler
- USB Host stack
- TCP/IP Stack with SSL
- Graphics & audio library
- 16- and 32-bit File System
- Sample software

Compatible Hardware

- StackableUSB Client Devices
- ICE
- ICD2

Mounting/Packaging

- ¼-Size 104™ Form Factor
- Standoffs, STDOFFUSB

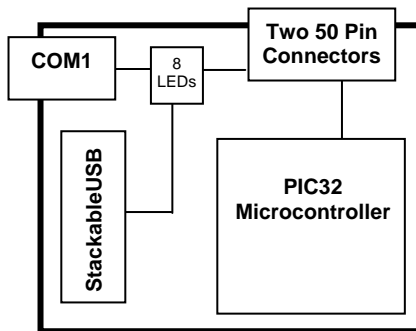

Specifications:

Mechanical:

- ❑ 1.85" x 1.78" StackableUSB
- ❑ ¼-Size 104™ Form Factor

Power Requirements:

- ❑ +5v ±5% at 100mA typical

Environmental:

- ❑ -40 to +85°C operating
- ❑ -40° to +85°C storage
- ❑ 5%-95% relative humidity, non-condensing

Processor:

- ❑ MIPS32® M4K™ 32-bit Core
- ❑ 80MHz, 1.56DMIPS/MHz
- ❑ 5-stage pipeline, 32-bit ALU
- ❑ Single-Cycle Multiply and High-Performance Divide Unit
- ❑ User and Kernel Modes to Enable Robust Embedded System
- ❑ Prefetch Cache Module to Speed Execution from flash
- ❑ 512KB Flash, 32KB SRAM

Serial Ports:

- ❑ COM1 available from 20-pin header

LEDs/Switches:

- ❑ Eight (8) Programmable user LEDs
- ❑ One (1) PB reset switch

Peripheral Features:

- ❑ 4-Channel Hardware DMA Controller with Automatic Data Size Detection
- ❑ USB 2.0 Compliant Full Speed Controller
- ❑ USB has a Dedicated DMA Channel
- ❑ Two (2) I2C Modules
- ❑ Two (2) UART Modules with:
 - RS232, RS485 and LIN 1.2 support
 - IrDA® with On-Chip Hardware Encoder and Decoder
- ❑ Parallel Master and Slave Port
- ❑ Hardware Real-Time Clock/Calendar
- ❑ Five 16-bit Timers/Counters (two 16-bit pairs combine to create two 32-bit timers)
- ❑ Five (5) Capture Inputs
- ❑ Five (5) Compare/PWM Outputs
- ❑ Five (5) External Interrupt Pins
- ❑ High-Speed I/O Pins Capable of Toggling at Up to 80MHz
- ❑ High-Current Sink/Source (18 mA/18 mA) on All I/O Pins
- ❑ Configurable Open-Drain Output on Digital I/O Pins

Analog Features:

- ❑ 16-Channel 10-bit Analog-to-Digital Converter
- ❑ 500 KSPS Conversion Rate
- ❑ Conversion Available During Sleep, Idle
- ❑ Two (2) Analog Comparators
- ❑ 5.5V Tolerant Input Pins (digital pins only)

Debug Features:

- 2-wire ICSP interface with unobtrusive Access and Real-time Data Exchange with Application
- 4-wire MIPS Standard Enhanced JTAG interface
- Unobtrusive Hardware-Based Instruction Trace
- IEEE Std 1149.2 Compatible (JTAG) Boundary Scan

External Connections:

- 2-pin power terminal
- StackableUSB
- 20-pin header for COM1
- 6-pin ICSP debug port
- 6-pin JTAG debug port
- 2x50-pin headers for I/O and peripherals

Internal Electrical Interface:

- StackableUSB
- USB 1.1 & 2.0 compatible, full-speed

Development Kit:

- Module with all options installed
- Complete cable set
- Documentation, schematics, sample software

Ordering Information:

OEM Single Board Computers:

USB1032-ST PIC32 Industrial Host
Microcontroller

Related Products:

STDOFFUSB StackableUSB Standoff Kit

Development Board Kits*

DK1032-ST PIC32 Industrial Host
Microcontroller; Windows-
ready development kit

**See Development Kit Specifications*