

Under Cabinet Light Panels From Inspired LED



Light Panels are ideally suited for under the counter task lighting applications, kitchen lighting, jewelry lighting, decorative lighting and reading lighting. Light Panels are brushed aluminum in color to blend with today's kitchen styles. Components are sold as a kit and can be also purchased individually to create a system of up to Ten Light Panels.

Features

- ✘ Low Cost Modular Design
- ✘ Both Warm and Cool Color Light Options
- ✘ Long Life 80,000HRs
- ✘ Easy Installation
- ✘ Highly Efficient PS
- ✘ Low Energy Consumption
- ✘ UV or IR free

Interconnection

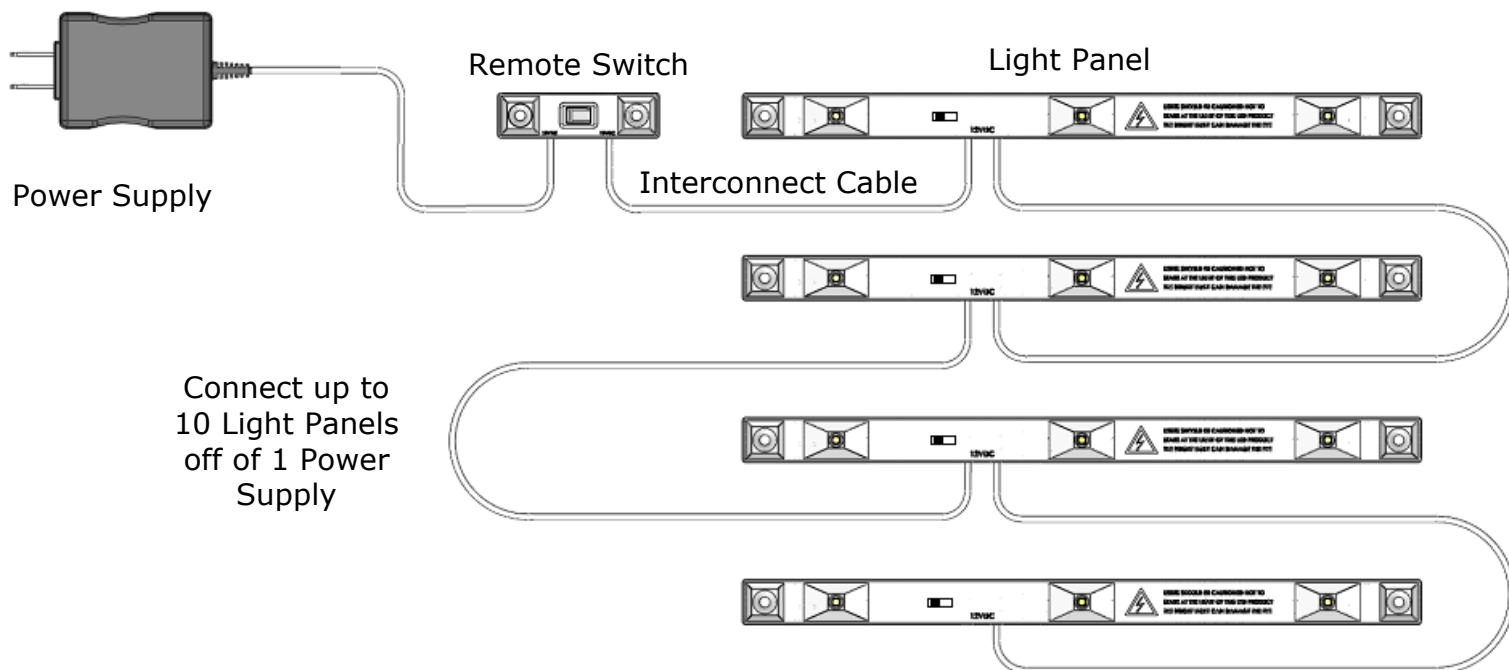

Specifications

- ✘ Power Supply – 45 x 60 x 25mm Energy Star UL Listed 100 - 120VAC in 12VDC / 1Amp output.
- ✘ $\frac{3}{4}$ Watt Light Panel – 280(L) x 15.5(W) x 10(H)mm 12VDC, 3 LEDs, Screw or Tape mounting.
- ✘ Remote Switch – 55(L) x 20(W) x 20(H)mm, Screw or Tape mounting.
- ✘ Interconnect Cable – 3', 6' & 12' lengths available.