

June 2009



Measurement *of* Light  
Measurement *with* Light

# BTS256-LED Tester

Light Analyzer  
for  
Luminous Flux & Illuminance  
Spectral Distribution & Color  
of  
Single LEDs, LED Modules  
LED Luminaires  
and other Light Sources

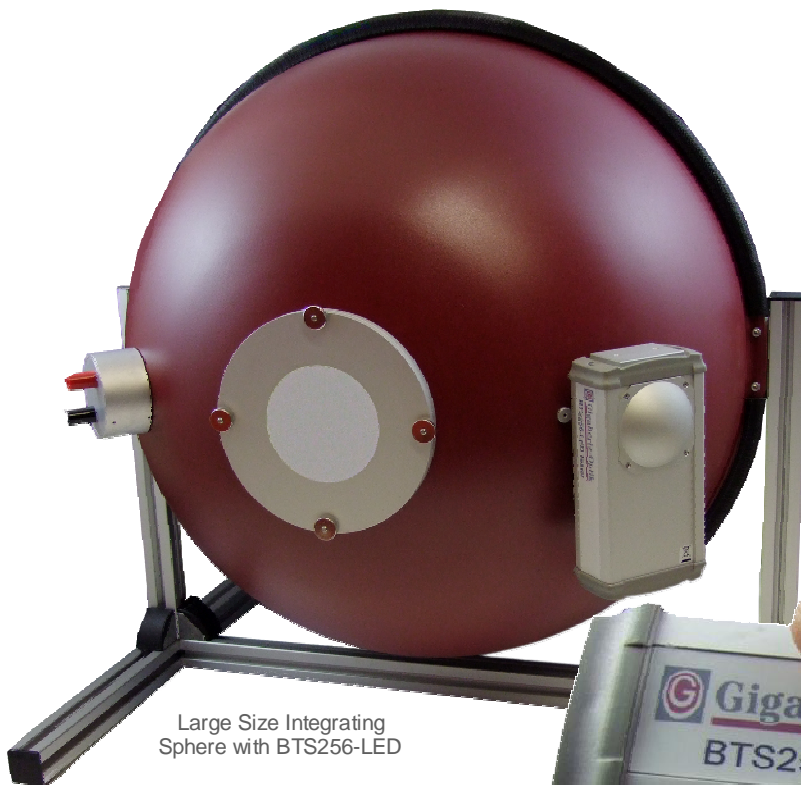

Large Size Integrating  
Sphere with BTS256-LED

BTS256-LED Tester



## ***New Light Measurement Technology for New Light Source Technology***

Traditional light meters for photometric or luminous color measurement quantities are built with photometric or tristimulus filtered detectors. Their spectral sensitivity is made to match as close as possible the spectral sensitivity of the human eye  $V(\lambda)$  and  $x,y,z$  color curves as standardized by CIE and DIN. For decades this type of light meter has been the basic tool for all kinds of light measurement applications in research and industry. It is still in use and does an excellent job when properly applied. Gigahertz-Optik GmbH is one of the leading manufacturers of traditional light meters with ongoing continuous development of new catalogue and OEM products. *But today's lighting industries continue to be transformed by new light source technologies.* Traditional incandescent lamps are being replaced by discharge lamps, physical (LED) and organic (OLED) Light Emitting Diodes. These sources are characterized predominantly by narrow wavelength band emission spectra. Since the ideal integral filter detector with a perfect spectral match to the target standard spectral function does not exist, measurement uncertainty runs high or is often unknown when measuring test sources with a different spectral distribution than the calibration source, typically Illuminant A. *New alternative light meter technologies* are required that can offer accurate and traceable light measurements in absolute units independent of the light source emission spectrum. *Spectral measurement technology* is recommended for this new type light source. But traditional moving grating monochromators representing the high end in light measurement instrumentation are too expensive for regular everyday industrial applications. *Diode array spectrometers* currently being promoted as the preferred measurement device to the standard light meter have limitations in absolute scale light measurements. Due to these limitations Gigahertz-Optik has developed a new highly accurate and cost effective light meter generation based on it's new BTS256P Bi-Technology Sensor. The BTS256-LED tester is the first light meter with this compact Bi-Tech Sensor that combines a photodiode and diode array for mutual improvement of each technology. The hand-held instrument allows qualification of luminous flux, spectral flux distribution and color data of single LEDs already assembled to a printed circuit board. In combination with a 6, 12 or 20 inch integration sphere, offered optionally, LED arrays or complete luminaires can be measured. Although compact in size the instrument offers all CIE recommended features like auxiliary lamps for integrating sphere based measurements and integrating time related offset compensation for the diode array. The full function BTS256-LED tester is favorably priced for small or large LED processing plants in incoming inspection, production control and final product qualification. Other spot source type light sources such as endoscopes, cool light fiber bundle sources, lensed sources can also be measured.

Light measurement plays a significant role in science and industrial research as well as in production and quality control. But it is not as well known a science as say voltage or current measurement. To help inform and support our customers in classifying their application and to use the BTS256-LED tester successfully this datasheet includes basic information on light and light measurement. Our technical sales support staff will be happy to provide individual product and application support if additional information is required.

### **Table of Contents**

	<b>Page</b>
Basics of LED Measurement : Light - Photometry - Light Measurement - Light Meter - Luminous Flux	2
Basics of LED Measurement : Luminous Intensity - Luminance - Illuminance - Color Sensations	3
Basics of LED Measurement:: Correlated Color Temperature - Color Rendering Index	4
Basics of LED Measurement:: Luminous Flux Measurement with Integrating Sphere - Substitution Error	5
Basics of LED Measurement: Spectral Flux Measurement - Illuminance Measurement	6
BTS256-LED Tester	7 - 8
BTS256-LED Tester Software	9 - 11
BTS256-LED Accessory: External Large Diameter Integrating Spheres - Illuminance Adapter	12 - 14
BTS256-LED Application Note: Luminous Flux and Color Measurement of LED Modules	15 - 16
BTS256-LED Application Note: Flux and Color Measurement of Surgical Endoscope Lighting	17
BTS256-LED Application Note: Switch-on Function Measurement	18
BTS256-LED Specifications	19
External Integrating Sphere Dimensions	20

## Basics of LED Light and Color Measurement

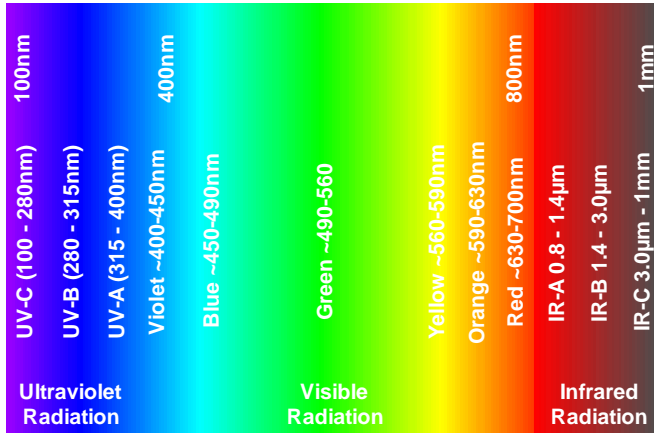

Optical Radiation Spectrum

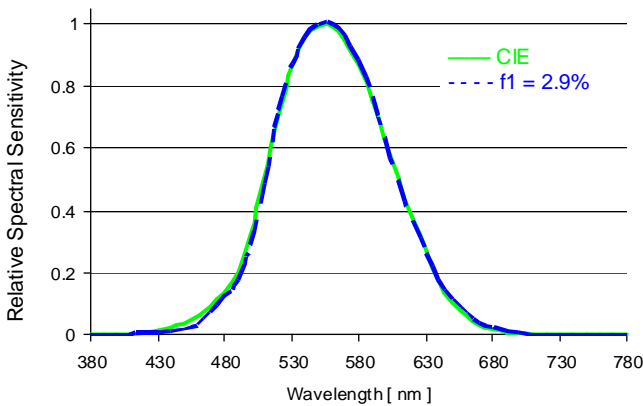

CIE Spectral Sensitivity of the Human Eye  $V(\lambda)$   
As Compared to Photometric Detector with Fine Spectral Match  $\lambda = 380 - 780\text{nm}$

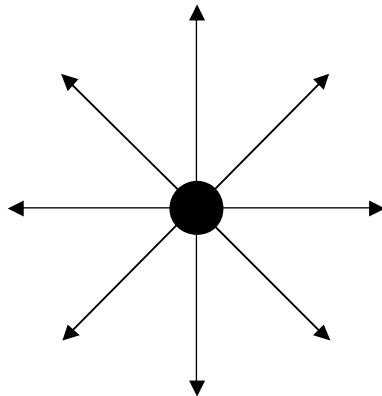

Luminous Flux of  $\Phi_v$  of a Light Source is defined as its total emitted Visible Optical Radiation (Light)

**Light**, or the visible part of the electromagnetic radiation spectrum, is the medium through which human beings receive a major portion of environmental information. Evolution has optimized the human eye into a highly sophisticated sensor for electromagnetic radiation. Joint performance between the human eye and visual cortex, a large part of the human brain, dwarfs recent technical and scientific developments in image processing and pattern recognition. In fact a major part of the information flow from external stimuli to our brain is transferred visually.

**Photometry** deals with the measurement of this visible light energy. The human eye perceives light with different wavelengths as different colors, as long as the variation of wavelength is limited to the range between 400 nm and 800 nm (1 nm = 1 nanometer =  $10^{-9}$  m). Outside this range, the human eye is insensitive to electromagnetic radiation and thus we have no perception of ultraviolet (UV, below 400 nm) and infrared (IR, above 800 nm) radiation. The **sensitivity of the human eye** to light of a certain intensity varies strongly over the wavelength range between 380 and 800 nm. Under daylight conditions, the average normal sighted human eye is most sensitive at a wavelength of 555 nm, resulting in the fact that green light at this wavelength produces the impression of highest "brightness" when compared to light at other wavelengths. The spectral sensitivity function of the average human eye under daylight conditions (photopic vision) is defined by the **CIE and DIN spectral luminous efficiency function  $V(\lambda)$** .

**Light measurement** when correlated to human vision perception is called photometry. The goal of photometric measurements is to quantify human impressions, e.g. brightness, brilliance, brightness contrast, darkness. CIE and DIN specify light measurement quantities for the quantification of light sources and lighting conditions in numbers directly relating to the perception of the human eye. Photometric light measurement quantities are distinguished from radiometric quantities by the index "v" for "visual".

**Light-Meters** for photometric measurements must offer a light spectral sensitivity correlating to that of the human eye, typically the day-light adapted eye response  $V(\lambda)$ . The quality of the  $V(\lambda)$  spectral match to that specified by CIE and DIN is one of the key parameters for photometer specifications. Spectral mismatch error is the key source for measurement uncertainty with light sources other than tungsten lamps. The most common photopic measurements quantities are:

**Luminous flux  $\Phi_v$**  is the basic photometric quantity and describes the total amount of electromagnetic radiation emitted by a source, spectrally weighted with the human eye's spectral luminous efficiency function  $V(\lambda)$ . Luminous flux is the photometric counterpart to radiant power. The unit of luminous flux is lumen (lm), and at 555 nm, where the human eye has its maximum sensitivity, a radiant power of 1 W corresponds to a luminous flux of 683 lm.

### Basics of LED Light and Color Measurement

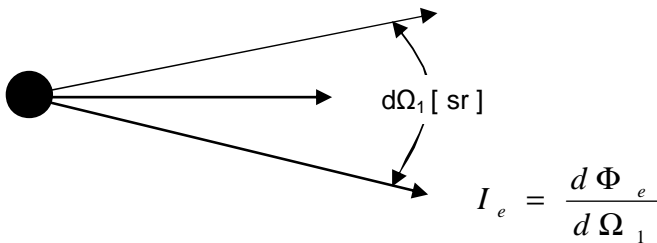

Luminous Intensity is Directional Flux

$dA_1 =$  area source

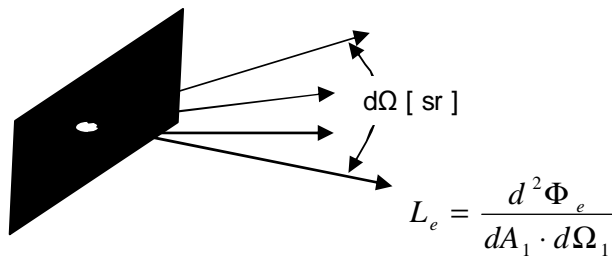

Luminance

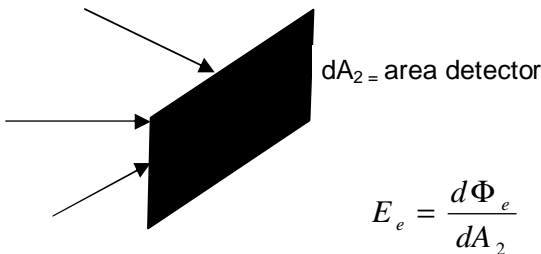

Illuminance is defined as Incident Luminous Flux  $d\Phi_v$  per surface area element  $dA$  at  $P$

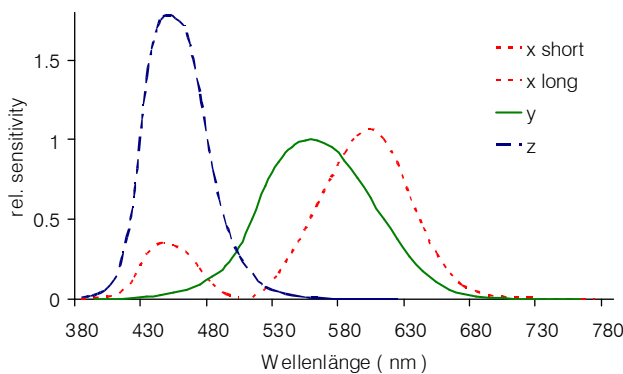

Human eye rod spectral sensitivity is responsible for color impressions

**Luminous intensity  $I_v$**  quantifies the luminous flux emitted by a source in a certain direction. In detail, the source's (differential) luminous flux  $d\Phi_v$  emitted in the direction of the (differential) solid angle element  $d\Omega$  is given by

$$d\Phi_v = I_v \cdot d\Omega \quad \text{and thus} \quad \Phi_v = \int_{4\pi} I_v d\Omega$$

The unit of luminous intensity is lumen per steradian ( $\text{lm / sr}$ ), which is abbreviated with the expression "candela" (**cd**).  $1 \text{ cd} = 1 \text{ lm / sr}$  and also foot-Lambert ( $1 \text{ cd/m}^2 = 0.2919 \text{ fL}$ )

**Luminance  $L_v$**  describes the measurable photometric brightness of a certain location on a reflecting or emitting surface when viewed from a certain direction. It describes the luminous flux emitted or reflected from a certain location on an emitting or reflecting surface in a particular direction (the CIE definition of luminance is more general. In detail, the (differential) luminous flux  $d\Phi_v$  emitted by a (differential) surface element  $dA$  in the direction of the (differential) solid angle element  $d\Omega$  is given by  $d\Phi_v = L_v \cos(\theta) \cdot dA \cdot d\Omega$  with  $\theta$  denoting the angle between the direction of the solid angle element  $d\Omega$  and the normal of the emitting or reflecting surface element  $dA$ . The unit of luminance is  $1 \text{ lm m}^{-2} \text{ sr}^{-1} = 1 \text{ cd m}^{-2}$

**Illuminance  $E_v$**  describes the luminous flux per area impinging upon a certain location of an irradiated surface. In detail, the (differential) luminous flux  $d\Phi_v$  upon the (differential) surface element  $dA$  is given by  $d\Phi_v = E_v \cdot dA$ . Generally, the surface element can be oriented at any angle towards the direction of the beam. Similar to the respective relation for irradiance, illuminance  $E_v$  upon a surface with arbitrary orientation is related to illuminance  $E_{v,\text{normal}}$  upon a surface perpendicular to the beam by  $E_v = E_{v,\text{normal}} \cos(\vartheta)$  with  $\vartheta$  denoting the angle between the beam and the surface's normal.

The unit of illuminance is **lux (lx)** and also foot-candle.

$$1 \text{ lx} = 0.0929 \text{ fc (lm/ft}^2\text{)}$$

Beside brightness sensitivity **color sensations** are human sensory perceptions and light measurement technology must express them in descriptive and comprehensible quantities. In light measurement applications luminous color of incident light and light sources is of main interest. According to the tristimulus theory, every color which can be perceived by the normal sighted human eye can be described by three numbers which quantify the stimulation of red, green and blue cones. If two color stimuli result in the same values for these three numbers, they produce the same color perception even when their spectral distributions are different. Around 1930, Wright and Guild performed experiments during which observers had to combine light at 435.8 nm, 546.1 nm and 700 nm in such a way that the resulting color perception matched the color perception produced by monochromatic light at a certain wavelength of the visible spectrum. Evaluation of these experiments resulted in the definition of the standardized **RGB color matching functions**



### Basics of LED Light and Color Measurement

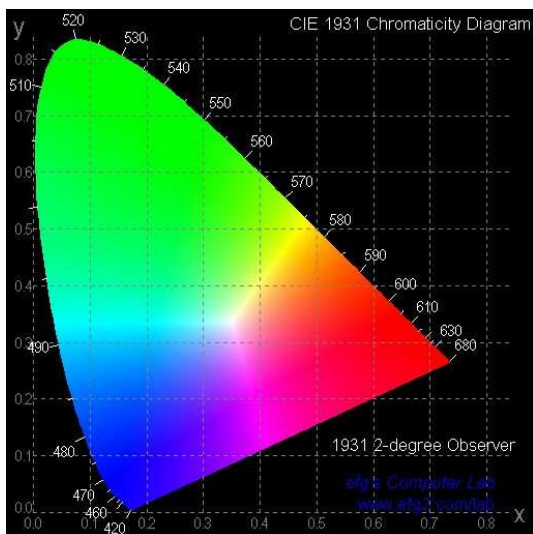

The CIE 1931 (x,y) chromaticity diagram

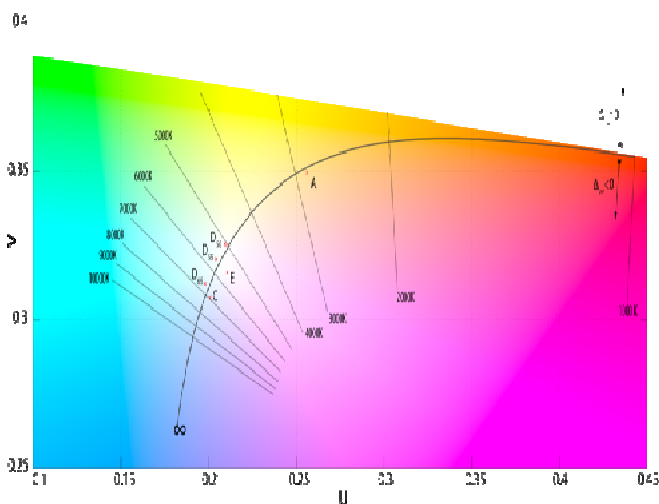

Correlated Color Temperature (CCT)

which have been transformed into the CIE 1931 XYZ color matching functions. These color matching functions define the CIE 1931 standard colorimetric observer and are valid for an observer's field of view of 2°. Practically, this observer can be used for any field of view smaller than 4°. Although the XYZ tristimulus values define a three-dimensional color space representing all possible color perceptions, for most applications the representation of color in a two-dimensional plane is sufficient. One possibility for a two-dimensional representation is the CIE 1931 (x, y) chromaticity diagram with its coordinates x and y calculated from a projection of the X, Y and Z values.

The Color Temperature (CT) is a specification for visible light and used to specify lighting conditions in lighting, photography, film recording, publishing, and other applications. The color temperature of a light source is determined by comparing its chromaticity with that of an ideal black body source. The color temperature describes the emission spectrum of a black body sources or sources which match the color temperature of a black body source. Most artificial light sources such as fluorescent or discharge lamps and LEDs are only nearly-Planckian black body sources. They can be judged by their correlated color temperature (CCT). The CCT can be calculated for any chromaticity coordinate but the result is meaningful only if the light sources are nearly white. The CIE recommends that the correlated color temperature should not be used if the chromaticity differs more than  $\Delta_{uv}=5 \times 10^{-2}$  from the Planckian radiator.

Color rendering is the effect of a light on the color appearance of objects. Sources that include light of all spectral colors, e.g. sun light, effect natural color sensations from illuminated objects. Here the color rendering is good. Light sources with irregular spectral color distribution effect unnatural color sensations. Here the color rendering is poor. If for example the color of the object is not included in the source spectrum the color rendering is gray.

The Color Rendering Index CRI specifies the quality of the color rendering of illuminants. The CRI is calculated by comparing the color rendering of an sample source to that of a reference source. For example a black body radiator with CCT below 5000K as compared to day light source like D65 with CCT higher than 5000K. A selection of reflective test color samples (TCS), specified by the CIE are used to calculate the CRI of a test lamp. The first eight samples with relative low saturation are used to calculate the general CRI  $R_a$  of a light source. The other seven samples provide supplementary information. Four are with high saturation the others represent well known objects.

CR	Appearance	CRI	Appearance
Ra	General CRI	R8	Light reddish purple
R1	Light greyish red	R9	Strong red
R2	Dark greyish yellow	R10	Strong yellow
R3	Strong yellow green	R11	Strong green
R4	Moderate yellowish green	R12	Strong blue
R5	Light bluish green	R13	Light yellowish pink (Skin)
R6	Light blue	R14	Moderate olive green
R7	Light violet	R15	Asian skin

Color Rendering Index Reference Colors

## Basics of LED Light and Color Measurement

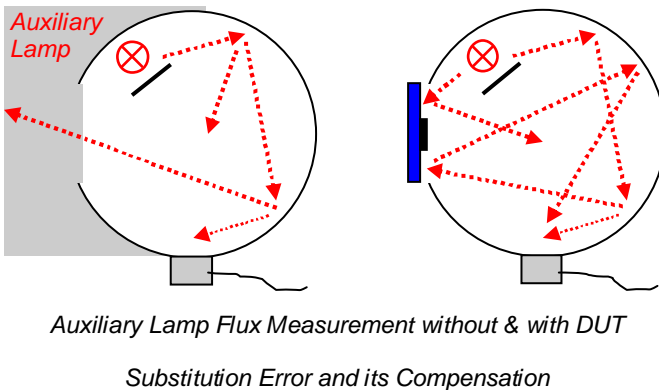
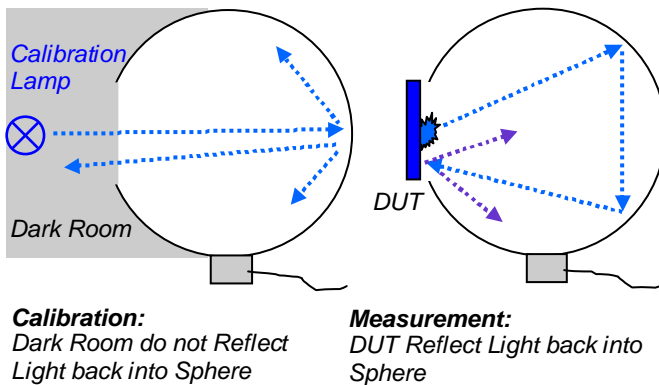
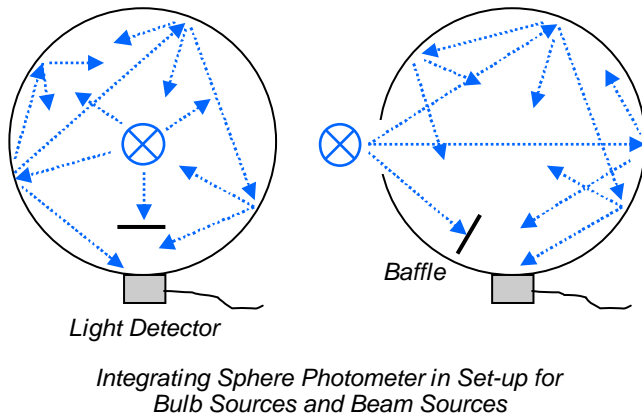
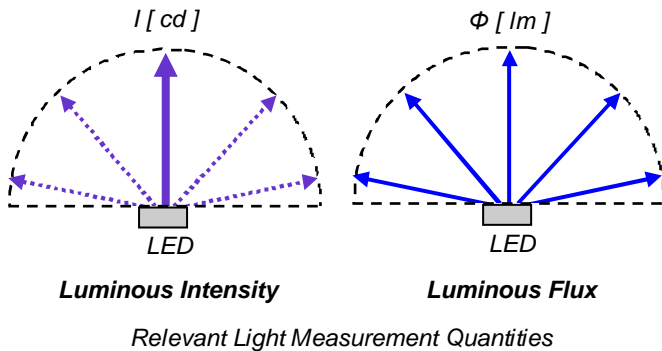

**Light Emitting Diodes (LED)** are semiconductor device incoherent light sources with high efficacy electrical power to light power conversion. As with any semiconductor device, operating temperature effects changes in light output and color performance. This is referred to as a device's temperature coefficient. Thermal management is therefore of primary importance in the successful implementation of LEDs. **Due to thermal drift** LEDs are often operated in pulsed mode. High peak intensities can be generated in this mode with reduced average electrical power and therefore reduced junction temperature. Sorting or grading of individual LEDs by color differences caused by tolerances in the semiconductor process is a common practice offered by most semiconductor manufacturers. But due to differences in LED manufacturer's sorting processes and environmental conditions, the LED lighting industry is forced to do in-house qualification measurements.

**The most common light measurement quantity used in LED testing is luminous flux measured in lumen.** This quantity corresponds to LED efficacy by correlation of the total light output to the electrical power. Measurement of the total light output in lm instead of luminous intensity in cd produces much better reproducibility because it is independent of spatial light distribution which may be influenced by temperature, humidity, distance, different viewing angles, misalignment and other experimental error. In research and industry the most commonly used measurement devices for luminous flux are **light meters with an integrating sphere**. The integrating sphere acts as a light integrator for spatially emitted light. The light source may be mounted inside or outside the sphere. The integration effect is the result of multiple diffuse reflections on the diffuse reflecting surface of the hollow sphere which results in a uniform light distribution at the sphere surface. The illuminance measured at any position on the integrating sphere surface is therefore an indicator of the total flux generated by a light source inside or outside of the sphere. **The size of the integrating sphere** should be much larger than the size of the test sample to keep measurement uncertainty low and independent of the spatial light emission characteristics of the test sample. If a smaller integrating sphere is used this must be accounted for in the calibration procedure of the measurement device.

**One large source of measurement uncertainty** inherent with integrating sphere use is the **substitution effect**. During calibration of the sphere photometer some of the light irradiated into the sphere will exit the sphere through the measurement port and be absorbed in the dark room. But during actual use, the measurement port of the integrating sphere will be fully or partially covered by the device under test DUT. So light leaving the sphere through the measurement port will be reflected back into the sphere adding erroneously to the DUT light signal. Depending on the spectral reflectivity and color of the DUT the re-reflected light will vary in intensity and color and effect an unknown measurement error. Auxiliary lamps are used to compensate this substitution error by measuring the signal of the auxiliary lamp with

### Basics of LED Light and Color Measurement

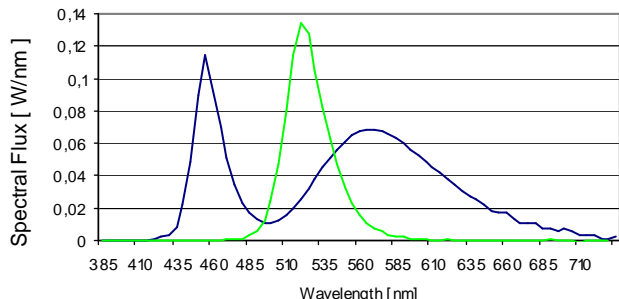

Spectral Flux of LED Measured with BTS256-LED Tester

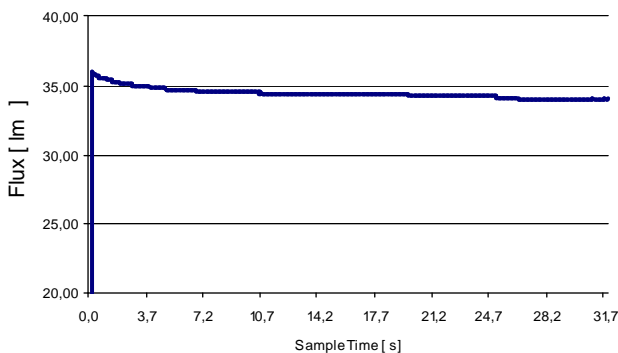

LED Switch-on Characteristic Measured with BTS256-LED

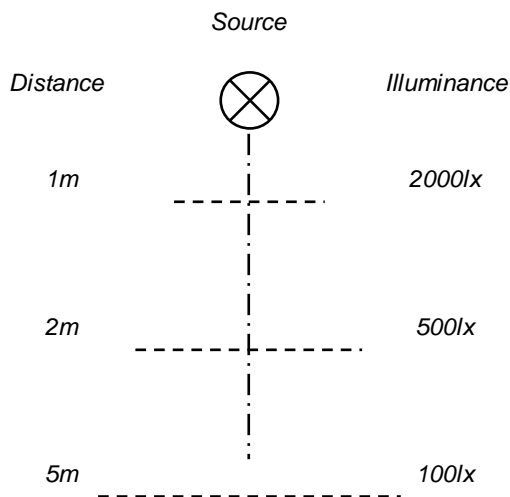

Distance dependent Illuminance Specification

and without the DUT at the measurement port of the integrating sphere. The difference in intensity is used as a correction factor for subsequent measurements of the same kind of DUT.

Along with light intensity and color data, **spectral intensity distribution** is another important test property in LED analysis. Spectrometer based light meters are used for this type of measurement. Filter type light meters employing photometric or tristimulus (RGB) detectors are restricted to comparative or relative measurements, e.g. LED sorting and binning against gold-standards. However spectrometers offer different levels of quality levels, especially diode array type spectrometers which are often limited by intensity linearity and stray light characteristics.

An alternative method is **to mate a photodiode with a diode array** like Gigahertz-Optik's BTS256P Bi-Technology Sensors. It's **photodiode** with a precise photometric response provides a highly linear ratio between light input and signal output over a very wide dynamic range for very accurate luminous flux measurements. The photodiode also offers a fast response time mostly independent from the light intensity so that the measurement signal of the photodiode can be used for **fast data logging** and **pulse synchronized measurement** applications. **Spectral distribution data** is provided by a separate diode array sensor. The spectral data enables the measurement device to calculate **color data** e.g. xy and u'v' color coordinates, color temperature CT, correlated color temperature CCT, color rendering index CRI, peak wavelength  $\lambda_{peak}$  and dominant wavelength.

Typical semiconductor light source (SLS) based luminaires consist of several individual LEDs. So the ideal light meter for this SLS type light source should support the complete production process. This includes the qualification of unassembled LEDs or on board mounted LEDs, the complete LED Matrix and the complete luminaire assembly. The two most common measurement quantities for LED testing are luminous flux and color. The recommended measurement quantities for luminaire testing are luminous flux and illuminance. Illuminance is typically presented in luminaire specifications as function of distance for the benefit of lighting designer and architects. State of the art light meters like Gigahertz-Optik's BTS256-LED tester support the measurement of single LEDs, LED arrays and SLS luminaires.

### BTS256-LED Tester

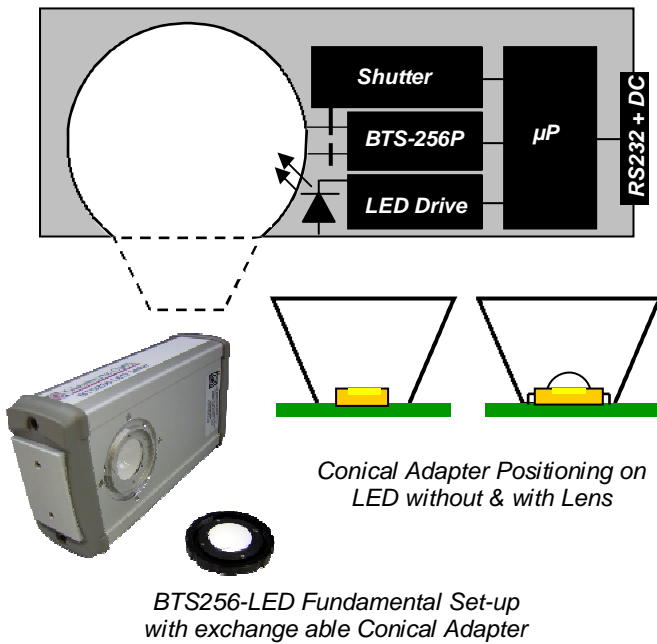

#### Common Incident Light Polychromatic or Monochromatic

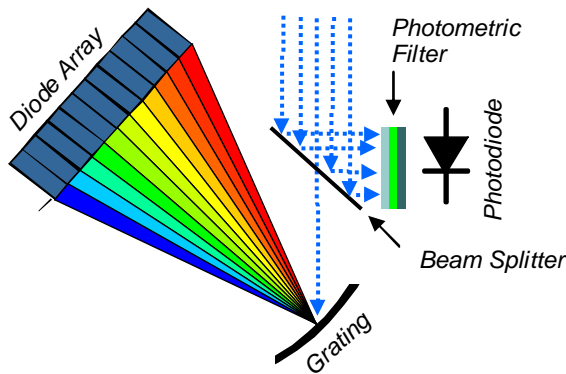

*BTS256P Light Detector Basic Set-up Design*

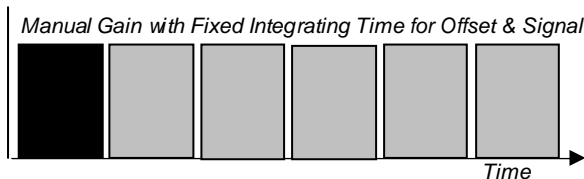
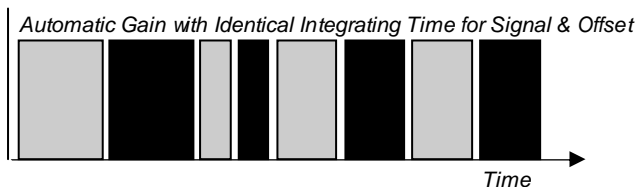

*Offset Compensation Measurement Modes*

The compact and portable design of BTS256-LED tester belies the fact that it is one of the most powerful and unique instruments available for the measurement of luminance flux and spectral data of LEDs and other light sources. The design goal was to make an accurate cost effective light and color meter that could be brought on-line to the application. The end user is able to measure his light sources under real application conditions like LEDs assembled and operated on printed circuit boards (board-mounted LEDs).

The BTS256-LED design includes a compact size **integrating sphere**. The integrating sphere coating is Gigahertz-Optik's rugged ODM98 type OP.DI.MA. with a nearly perfect diffuse reflection characteristic. To reduce risk of contamination the sphere input is sealed with a 3D formed window. The light input is a conical type adapter which can be set over the DUT LED. The adapter with its **bayonet type connection** is exchangeable. Adapters with other port sizes or for use as spare parts are available. To measure the total flux emitted by the LED the surface of the LED must be within the conical adapter. To **compensate substitution errors** white LEDs act as auxiliary lamps. The LEDs are remote controlled to support the substitution correction function included in the G.O.O.S. software supplied with the instrument.

Gigahertz-Optik's state of the art BTS256-P light sensor offers a **fine photometric response** photodiode for accurate wide dynamic range flux detection. To work in concert with the integral detector a compact **low stray light spectrometer** is included. It's 256 pixel CMOS sensor enables spectral distribution measurements with a 5nm bandwidth for color measurements. An ultra compact remote controlled shutter is provided for **on-line offset compensation** of the diode array through dark signal measurement. For best signal to noise ratio the offset compensation is done in an on-line mode for each measurement with identical integration time equal as that of the measurement. In applications where the flux level of different test samples remains within the same range, in production control for example, a fixed integrating time and therefore a fixed offset value can be used. This reduces the measurement time since the on-line dark signal measurement can be omitted.

The spectral measurement data are **absolutely scaled** for spectral flux distribution in W/nm. Spectral flux peak intensity wavelength, dominant wavelength, xy and u'v' color coordinates, color temperature and color rendering index are calculated by the spectral measurement data. The spectral data is also used for **on-line correction** of the spectral mismatch error of the photometric detector to CIE spectral V(λ) response. The mismatch is caused by limitations in current optical filter manufacturing technology. By knowing the spectral sensitivity of the photometric detector, the emission spectrum of the calibration lamp used for calibration and the emission spectrum of the test sample (DUT) a correction factor can be calculated using the published a(Z) method. In applications where emission spectra does not vary a constant a(Z) factor can be used for flux measurement with pho-



## BTS256-LED Tester

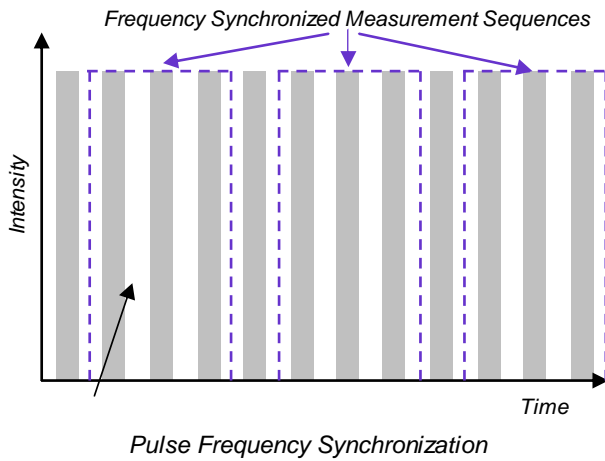

BTS256-LED in Remote Set-up

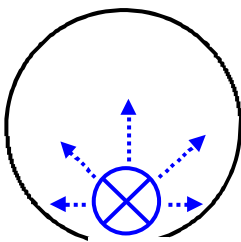

Calibration with Spatially Emitting Calibration Lamp



Hard-shell Carry Case

photodiode detector only.

The **fast response** time of the integral detector is useful in applications where spectral data is not needed, e.g. flux inspection..

For more stable measurements in applications with low frequency modulated light or light with AC components the BTS256P sensor can be **synchronized to the frequency** of the light signal. The fast integral sensor (photodiode) is used to detect the frequency of the AC component of the light. Both sensors (integral and diode array) are then synchronized to that frequency. The measurement time (integration time) is set to integer multiples of the input signal AC component time period.

The BTS256-LED tester is **fully remote controlled** via it's RS232 interface. To reduce the data transfer the **micro-processor** supports the complete set-up, measurement and calculation routine. A USB to RS232 adapter is supplied to allow connection to the more commonly supplied USB interfaces in today's laptops and PCs. The USB/RS232 adapter also passes the required 5V operating voltage from the USB to the RS232 interface. The RS232 interface and the USB to RS232 adapter are modified to supply power to the LED tester. Both devices are therefore non standard devices and should only be used with the BTS256-LED and not on any other conventional interface device.

To operate the BTS256-LED it needs to be connected to a laptop or PC with USB interface by using the USB-RS232 adapter (picture 10.2) supplied. The adapter also supplies the 5VDC operating voltage from the computer power supply to the BTS256-LED. The driver software for the adapter is available on the G.O.O.S. software CD and installed during the G.O.O.S. installation routine.

Because the BTS256-LED integrating sphere is relatively small, to reduce measurement uncertainty calibration is performed using a calibration lamp with spatial emission characteristics that simulates that of the typical device under test. Calibration is done by Gigahertz-Optik's calibration laboratory for light measurement quantities against calibration standards traceable to national and international metrology laboratories. The calibration procedure, absolute values with calibration uncertainty are stated on the individual calibration certificates supplied for each device. Re-calibration is recommended every 12 months.

The BTS256-LED tester is designed for remote control operation. The operation software, based on Gigahertz-Optik's G.O.O.S. is supplied with the instrument. **Gigahertz-Optik's Object Oriented Software G.O.O.S.** is the basis for remote control operation of many of Gigahertz-Optik's products. The main concept is hardware and functional DLLs with a graphical user interface (GUI). The BTS256-LED Tester G.O.O.S. version supports set-up, measurement routine, data display and presentation as well as documentation.

### BTS256-LED Tester

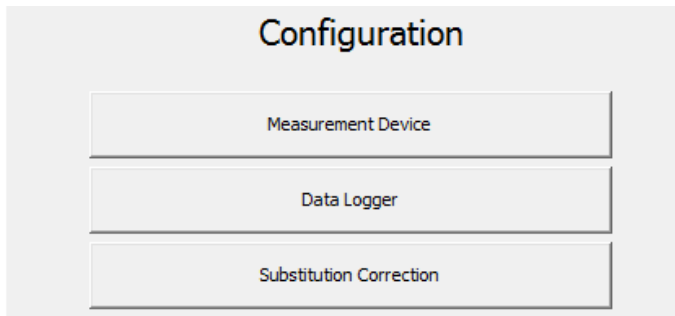

The software supports measurement routines in a simple way for uncomplicated light and color measurements. Normally the configuration file is used only once when the system is first set-up or in cases where different measurement routines are used.

The **measurement device configuration** includes independent set-up of the integral and spectral measurement device. The **data logger configuration** enables setting of the sample rate and a start and stop time for remote start of data logging in absence of the operator. The **substitution correction configuration** is used on evaluation of substitution error correction files during one measurement session with a reload function to enable the storage of substitution correction factors for future use.

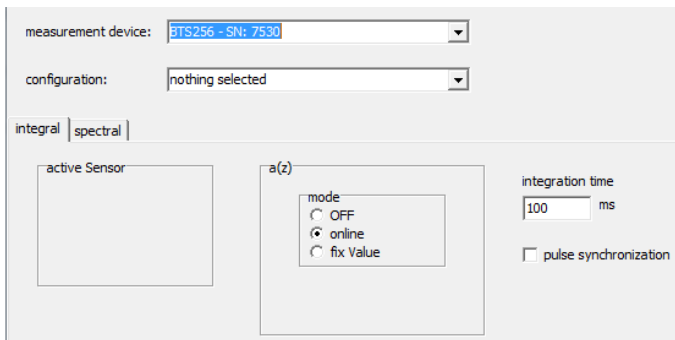

Configuration window for the integral measurement device.

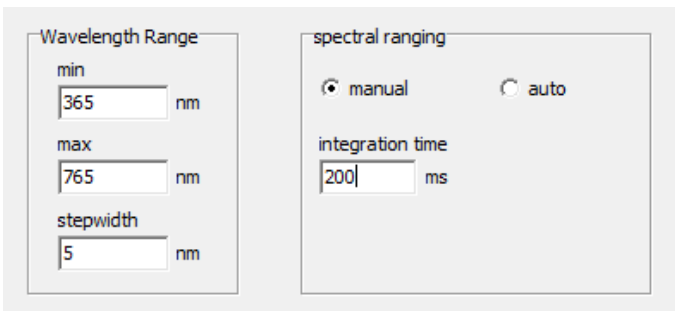

Configuration window for the spectral measurement device.

Numerical measurement display with functional buttons. The graphic shows the activated display of the color rendering measurement values.

Phi [lm]	x	y	T	0% array saturation 100%
2,499E+1	0,306	0,301	7220	<div style="width: 100%; height: 10px; background: linear-gradient(to right, blue, white);"></div>
a(z)	dominant wavelength [nm]	peak wavelength [nm]	peak level [W/nm]	
0,995	472,6	458,1	1,022E+0	
<input checked="" type="checkbox"/> show CRI				

Ra	85,1	R5	81,9	R10	81,6
R1	87,6	R6	82,2	R11	72,6
R2	94,7	R7	87,0	R12	53,5
R3	91,4	R8	78,5	R13	91,8
R4	77,5	R9	45,9	R14	95,5

display data  
 numeric  
 graphic

scan  
start  
stop  
reset

store data  
clear data  
print

meas time [ms]  
150

EXIT

### BTS256-LED Tester

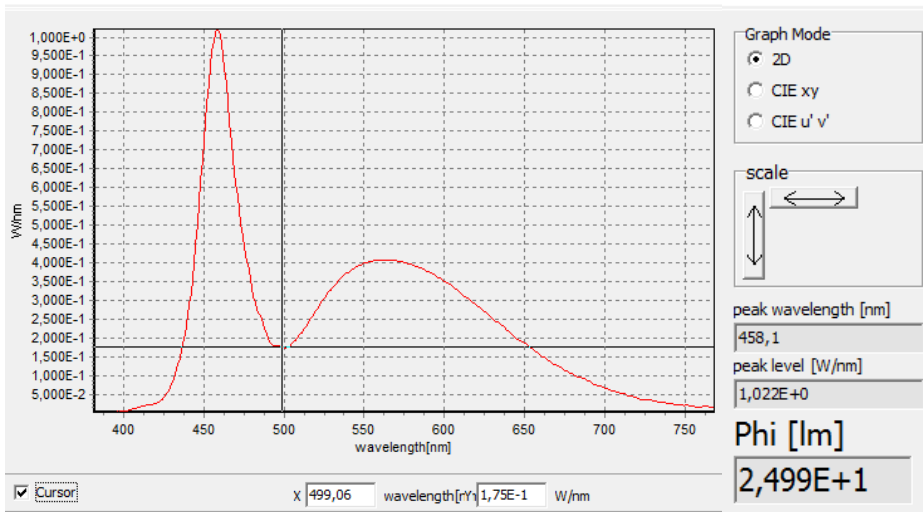

The graphic display mode includes a two dimensional display of the spectral flux distribution in W/nm as well as the CIE xy and u'v' graph.

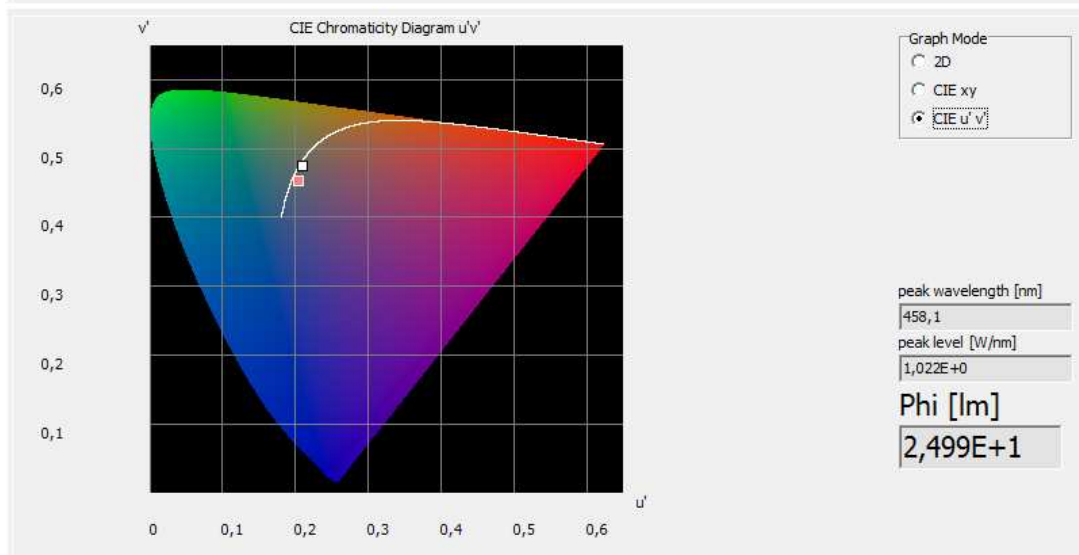
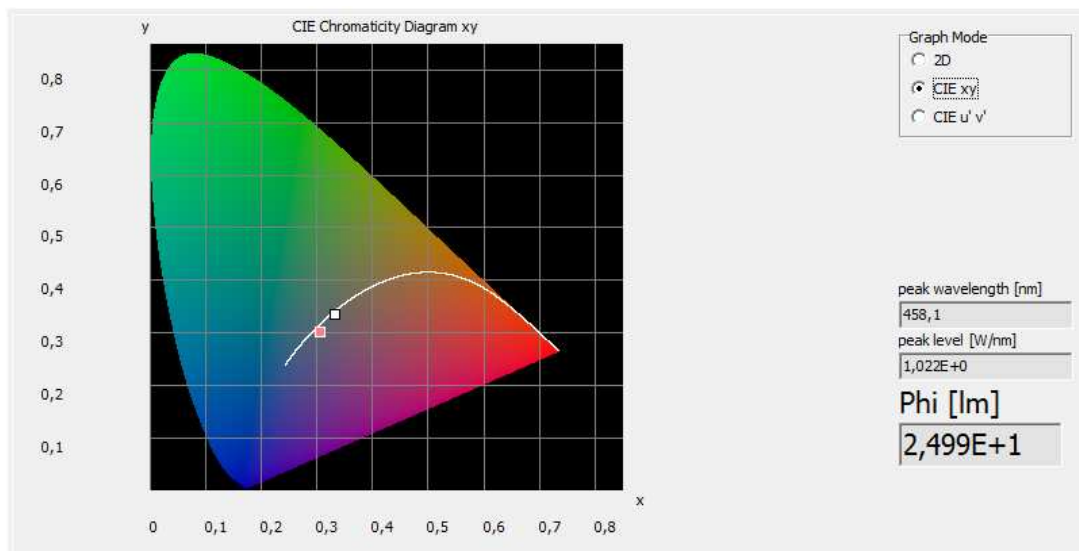

### BTS256-LED Tester

The GOOS software allows storage of the integral measurement values and spectral data and also supplies a simple measurement protocol to print-out documentation.

### measurement protocol

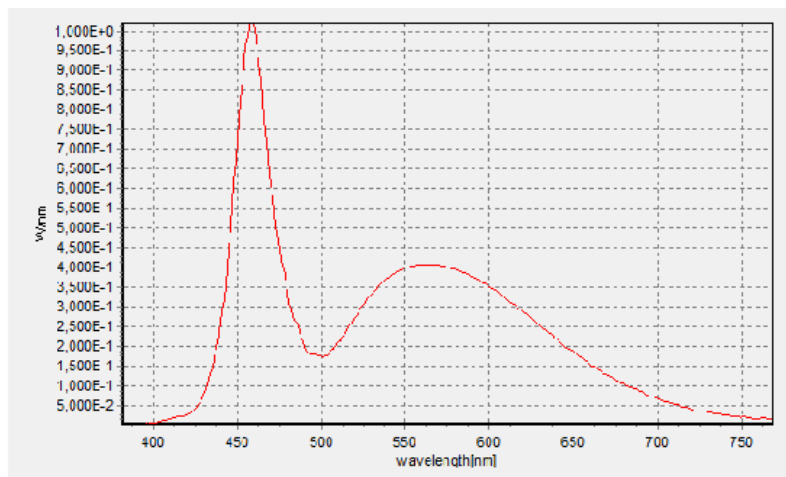

Comment  
White Golden Dragon

### tabular data

Time	meas. value		unit	CCT	x	y	peak wl[nm]	peak power[W/nm]						
4	24,987		lm	7220,3	0,306	0,300	458,1	1,0224						
Ra	R1	R2	R3	R4	R5	R6	R7	R8	R9	R10	R11	R12	R13	R14
85,1	87,6	94,7	91,4	77,5	81,9	82,2	87	78,5	45,9	81,6	72,6	53,5	91,8	95,5



## BTS256-LED Accessory

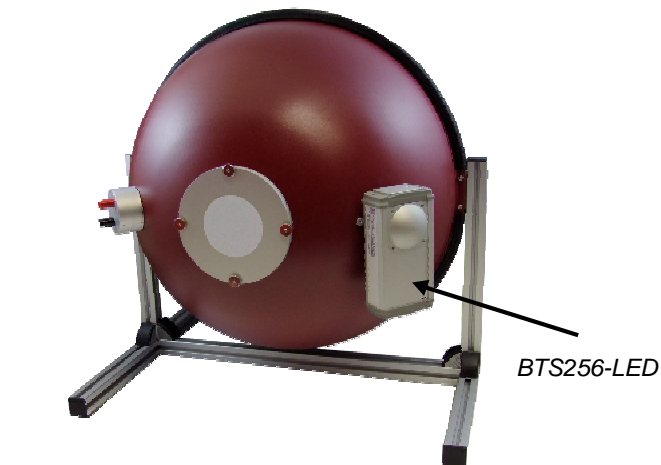

### Large Diameter Integrating Spheres:

**Large size** LEDs, LED arrays, LED modules, LED lamps and compact sources require integrating spheres with a larger diameter than the one built into the BTS256-LED tester. For these applications the BTS256-LED tester can be combined with large diameter integrating spheres. The spheres are built from components out of Gigahertz-Optik's UM<sup>1)</sup> series the most extensive integrating sphere system programs available.

\*) *Ulbrichtsche Kugel (Integrating Sphere)* is named for the designing engineer Richard Ulbricht (1849 to 1923). *M* stands for **Modular** concept

### Spheres for Beam Type Sources ( $2\pi$ Geometry):

Due to the narrow or **hemispherical beam** characteristic of single LEDs and LED arrays and modules integrating spheres in a  $2\pi$  set-up are commonly used. The device under test DUT is placed at the measurement port looking into the sphere so that all emitted light enters the sphere. The size of the measurement port must correlate to the maximum size of the test device because all emitted light of the LED must enter the sphere.

### Spheres for Bulb Type Sources ( $4\pi$ Geometry):

For LEDs and other sources with a spherical emittance characteristic the device under test must be placed in the center of the sphere in what is called a  $4\pi$  configuration. Positioning the DUT in the center of the sphere can be done through the measurement port using an insertable sample holder. An alternative is to use a hinge frame integrating sphere that allows the sphere to open for sample handling.

All spheres are set-up with an **auxiliary lamp** for correction of the substitution error caused by test samples and other absorption factors. The substitution correction measurement routine is integrated into the set-up and measurement routine of the G.O.O.S. software supplied with the BTS256-LED tester. Note that the Gigahertz-Optik BTS256-LED-ALP power supply remote on-off control is supported by the software as well.

### Illuminance Measurement Adapter:

The BTS256-LED tester measurement functionality can be extended for illuminance measurements in lux. For this purpose the input nozzle used for lumen measurement is exchanged with a large 20mm diameter diffuser adapter. The screw-on type mount offers tool-less exchange and precise positioning. The software supplied with the BTS256-LED tester supports the illuminance measurement including spectral distribution and luminous color data. The illuminance option includes both an illuminance and color sensitivity calibration of the BTS with the adapter so if ordered later on factory recalibration will be necessary.



Simple BTS256-LED Assembly to Sphere

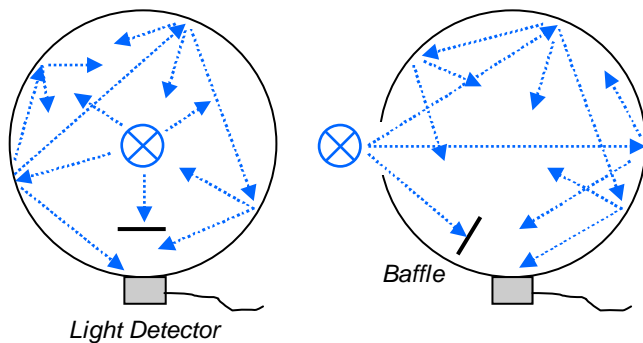

Integrating Sphere Photometer in  $4\pi$  &  $2\pi$  Set-up for Bulb Sources and Beam Sources Respectively



BTS256-LED Tester with Illuminance Adapter

## BTS256-LED Accessory

### UMBB-210-BTS256-LED:

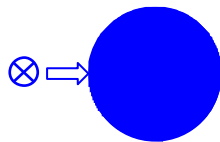
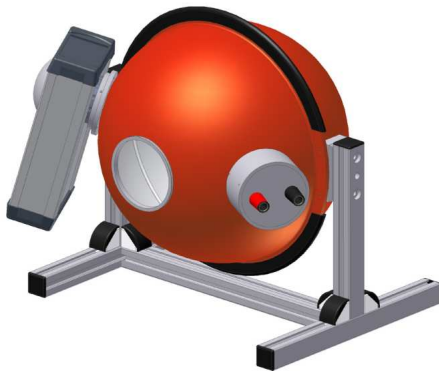

CIE Publication 127 states that 8 inches / 200 mm diameter is the minimum size for luminous flux measurements using integrating spheres. The model UMBB-210-BTS256-LED 8.3 inch / 210 mm diameter integrating sphere meets this recommendation. The  $2\pi$  geometry sphere set-up for beam emitter type lamps is comprised of components from Gigahertz-Optik's UM integrating spheres series. The sphere is coated with Gigahertz-Optik ODP97 coating (Barium Sulfate) and includes a stable bench-top stand. The 2.5 inch / 63.5 mm diameter measurement port is supplied with a 2 inch / 50.5 mm diameter port reducer with knife edge design. This aperture is used for the calibration of the integrating sphere with BTS256-LED tester. The substitution effect error caused when using an optionally available smaller diameter port reducer or full aperture with a port reducer is evaluated and corrected with the auxiliary lamp. The auxiliary lamp is also used to correct the substitution error effected by the test sample itself. The BTS256-LED-ALP auxiliary lamp power supply is offered by Gigahertz-Optik for proper and remote controlled operation of the auxiliary lamp. The calibration certificate supplied for integrating sphere with the LED tester includes the description of the calibration procedure and the traceability of the calibration.

### UMBB-500-BTS256-LED:

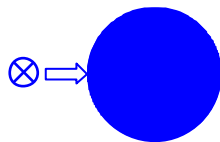
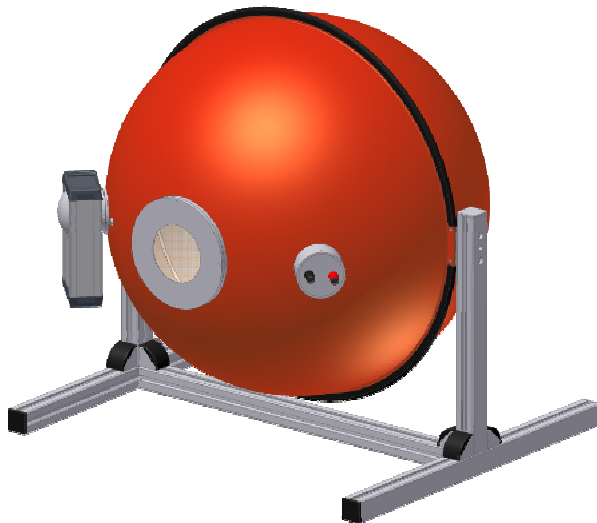

20 inch / 500 mm diameter  $2\pi$  geometry integrating sphere set-up for measurements of beam emitter lamps is done with components from Gigahertz-Optik UM integrating spheres series. The sphere is coated with Gigahertz-Optik ODP97 coating (Barium Sulfate) and is includes a stable bench-top stand. The 5 inch / 127 mm diameter measurement port is supplied with a 3 inch / 76.2 mm diameter port reducer with knife edge design. This aperture is used for the calibration of the integrating sphere with BTS256-LED tester. The substitution effect error caused when using an optionally available smaller diameter port reducer or full aperture with a port reducer can be evaluated and corrected with the auxiliary lamp. The auxiliary lamp is also used to correct the substitution error effected by the test sample itself. The BTS256-LED-ALP auxiliary lamp power supply is offered by Gigahertz-Optik for proper and remote controlled operation of the auxiliary lamp. The calibration certificate supplied for integrating sphere with the LED tester includes the description of the calibration procedure and the traceability of the calibration.

### UMPR Port Reducer:

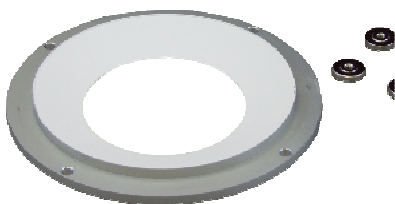

UMPR-5.0-50 Port Reducer with Knife-edge

Gigahertz-Optik supplies different size exchangeable port reducers for the measurement ports of the UM type integrating spheres. This enables the user to adapt the size of the measurement port to that of the test sample (DUT). The port reducer's knife edge optimizes the sphere's acceptance angle. Any change in sensitivity effected by the port reducer is compensated using the auxiliary lamp.

## BTS256-LED Accessory

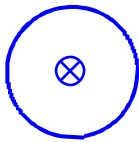
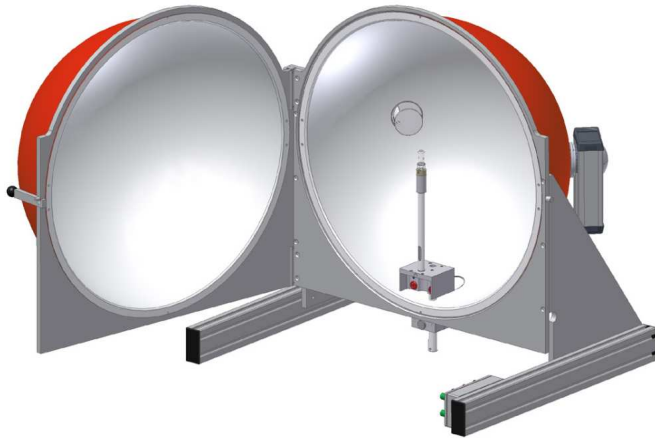

### UMBB-500HF-BTS256-LED:

20 inch / 500 mm diameter integrating sphere set-up in  $4\pi$  geometry for measurements of all-directional bulb type light sources with components from Gigahertz-Optik UM integrating spheres series. The hinge frame stand allows one hemisphere to open for mount and removal of the device under test in the centre of the sphere. The UMSH-AP500 all-purpose sample holder supports positioning and electrical connection of the device under test in the sphere center position. An auxiliary port located at the bottom of the sphere enables handling of test devices with non standard cables and connections. A port plug is available to cover this port when not in use. The sphere is coated with Gigahertz-Optik ODP97 coating (Barium Sulfate). The substitution effect error due to light absorption by the test sample inside the sphere is evaluated and corrected with the auxiliary lamp. The BTS256-LED-ALP auxiliary lamp power supply is offered by Gigahertz-Optik for proper and remote controlled operation of the auxiliary lamp. The calibration certificate supplied for integrating sphere with the LED tester includes the description of the calibration procedure and the traceability of the calibration.

### BTS256-LED-ALP:

Gigahertz-Optik BTS256-LED-ALP power supply is available on option for use with external integrating spheres. It provides stable operation of the quartz halogen auxiliary lamp plus offers a trigger input for remote on/off control via the BTS256-LED-C USB/RS232 adapter supplied with the BTS256-LED tester. The power supply (110/230V 50/60Hz) can be manually set to the auxiliary lamp specifications in use.

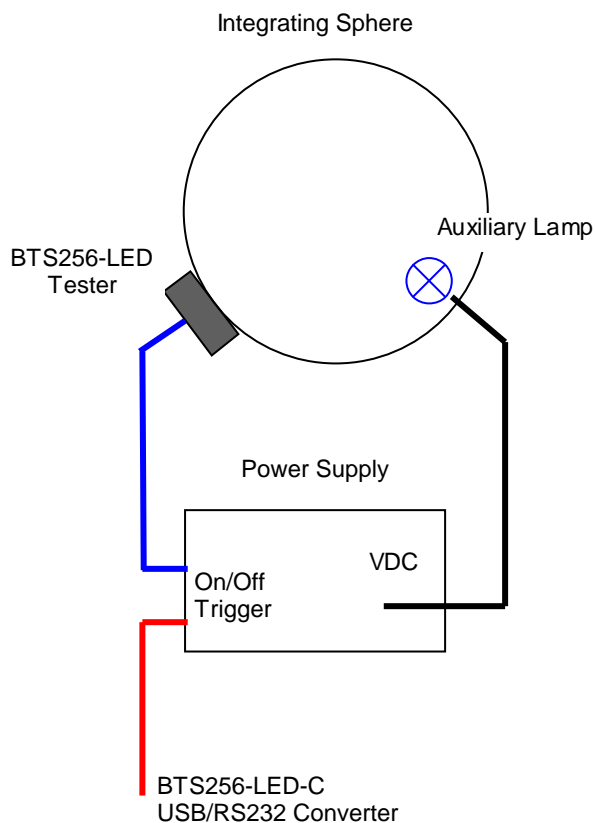

Set-up for Remote Auxiliary Lamp Control

## BTS256-LED Application: Flux Measurement of LED Modules

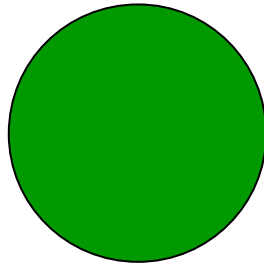
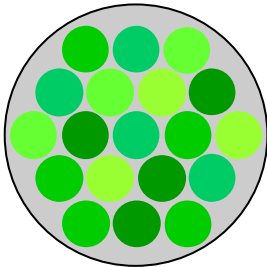

Area Source or Virtual Spot Source by Viewing Distance

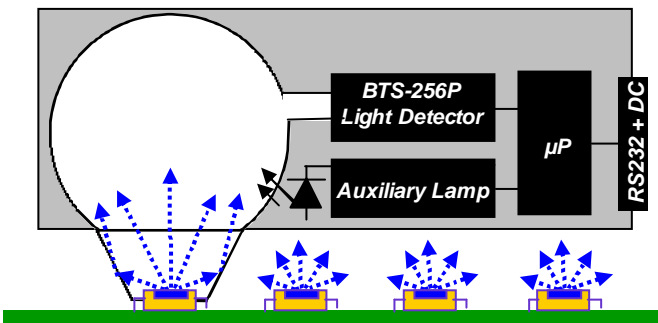

Flux Measurement of Single LEDs within a LED Array



Single LED Measurement with Conical Adapter

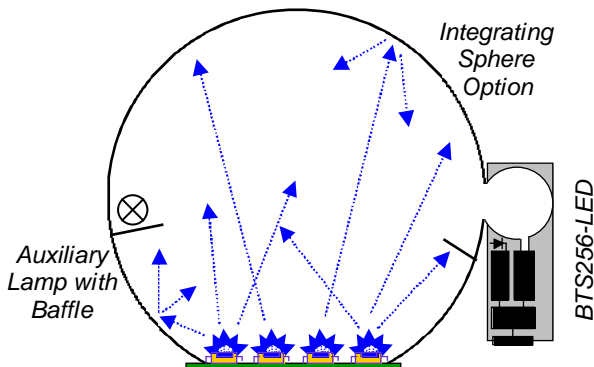

LED Array Measurement with Integrating Sphere Adapter

It is a very common practice to use a matrix of LEDs (LED Module) to increase total luminous flux. Qualification of such devices can be accomplished in two different ways:

1. Measurement of the single LED flux and color, then calculating the total flux and averaged color temperature by summing the measured values
2. Measurement of the integral flux and averaged color temperature of all LEDs in the matrix configuration

The main selection criterion for using one of these strategies over the other is whether the single LED flux and color uniformity is important or not. That question may be answered by classification of the LED matrix as a spot source or area source.

- A. For an area source the human eye will perceive the individual LED sources and therefore any variation in flux and color. So obviously the uniformity of all LEDs within the array must be individually qualified by flux and color measurements of each one.
- B. For a spot (point) source the integral of the flux and color of all LEDs will be perceived. A spot source is a point source emitting light equally in all directions (spherical symmetry). At a distance  $r$  that is much larger than the largest physical dimension of the source itself, the actual size of the source can be neglected and assumed that the light is emitted from a virtual point. As a rule of thumb, this approximation is justified if distance  $r$  is at least 10 times larger than the dimensions of the light source.

The BTS256-LED tester enables measurement of the total flux and color of discrete LEDs and LED matrix configurations.

### Measurement of single LEDs or discrete LEDs within a LED module configuration:

The conical adapter on the basic instrument serves as its input optic and collects all emitted light of single LEDs. The instrument must be positioned over the LED so as to ensure that all emitted light enters the conical adapter and therefore the instrument. Where space allows the LED under test may also project into the conical adapter. Light contamination from neighboring LEDs must not enter the instrument! Beside the measurement of assembled LEDs the BTS256-LED tester can also be used to measure LEDs mounted on a bar or rope in incoming inspection and for binning by flux and color characteristics.

### Measurement of LED modules:

The BTS256-LED tester measurement capabilities in terms of test sample size can be expanded using an integrating sphere. For example, an integrating sphere at 20 inch / 500mm diameter with a measurement port of 5 inch / 127mm diameter is offered. The port area can and should be reduced for smaller size test samples. For accurate measurement the surface of the LED must be positioned so that



**BTS256-LED Application: Flux Measurement of LED Modules**

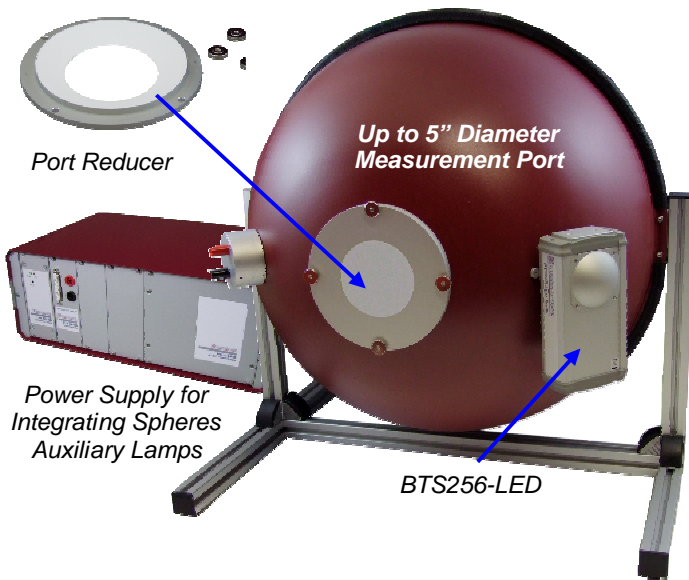

all emitted light enters the sphere. Multiple diffuse reflections within the sphere cause an average signal to be measured.

Integrating sphere based light meters require an auxiliary lamp to compensate for the substitution effect caused by the test sample!

*Integrating Sphere Model UMBB-500 to expand the measurement area of BTS256-LED up to 5 inch / 127mm Diameter. Port Reducer (2) or the Measurement Port enable the Port Size Adjustment to the Test Sample Size. The Remote Control Auxiliary Lamp support the Substitution Error Compensation effected by the Test Sample Itself*

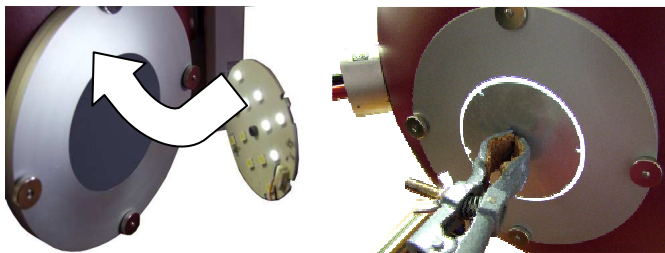

*BTS256-LED Tester with Large Size Integrating Sphere for Luminous Flux Measurements of LED Arrays*

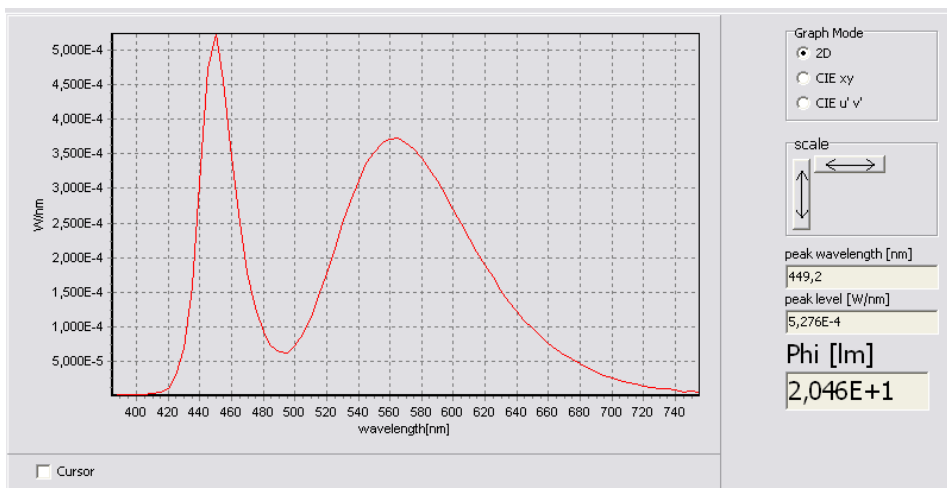

The BTS256-LED tester as a fully remote controlled measurement device requires a PC or Laptop for operation. The G.O.O.S. software (Gigahertz-Optiks Object Orientated Software) supports the measurement set-up of the photodiode and diode array integrated into the Bi-Technology Sensor. This includes offset compensation with the integrated electromagnetic shutter as well as the substitution compensation with the integrated auxiliary lamp. If an optional integrating sphere is used the software manages the additional calibration data and external auxiliary lamp assembled to the integrating sphere. The measured data is displayed in graphical and numerical format. Beside the print with preview function the measurement values can be stored in ASCII format and re-loaded into spreadsheet software such as Excel for individual processing and presentation.

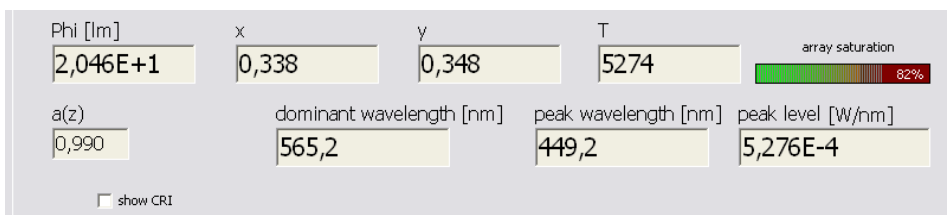

## BTS256-LED Application: Flux and Color of Surgical Endoscope Lighting



*Flux Output Qualification of Surgical Endoscope*



*Exchangeable Bayonet Type Alignment Adapter*

Surgical endoscopes are medical tools that assist doctors and surgeons in certain types of operations. The endoscope includes a light source for illuminating the objective of the surgical procedure. Beside luminous flux emission, color temperature is of interest for brightness and real color rendering of the tissue.

### Luminous flux:

Endoscopes do not typically fulfill the definition of a point source a prerequisite for illuminance measurements so illuminance is not the right type of measurement for qualification of these devices. The measurement of luminous flux is therefore the recommended and most often practiced method. Surgical endoscopes offer axial or radial orientation of their light output accompanied by different dispersions of the light beam. Total flux measurement with an integrating sphere as provided by the BTS256-LED tester makes flux measurements nearly independent of the light output geometry. To increase the reproducibility and accuracy of endoscope flux measurement alignment adapters that fix the scope at the input optic are recommended.

### Luminous Color:

Color rendering effected by the endoscope lighting is important for real color impression by the doctor. For color rendering qualification of endoscopes the correlated color temperature needs to be measured and regularly monitored. Because endoscope lighting is a cold-light exhibiting non-standard illuminant characteristics, tristimulus luminous color filter meters are not the best measurement tool. Luminous color measurements using spectral data calculations are recommended. Spectral measurement devices should offer a spectral resolution of 5nm.

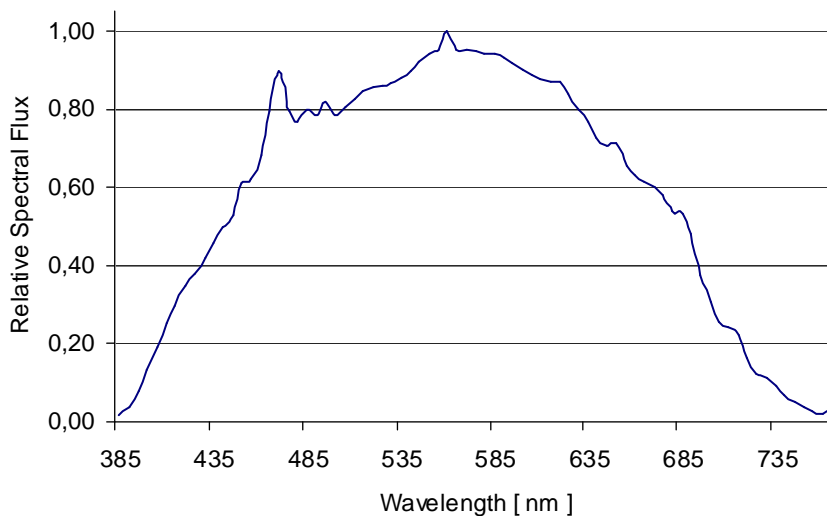

*Emission Spectrum of Cold White Endoscope Light*

### Spectral Flux Distribution:

For better contrast and to enhance an object improved illumination strategies such as NBT (Narrow Band Imaging) are in use. Tissue structures not visible under white light illumination become visible by suppressing spectral parts of the white light endoscopic picture. The only way to qualify NBT illumination is by measurement of the emission spectrum. Comparison of the measured emission spectrum with a standard spectra can be made and used as a qualification parameter. Beside the spectral flux distribution the BTS256-LED tester measure flux brightness too.

### BTS256-LED Application: LED Matrix Uniformity Measurement



Measurement of Individual LEDs in LED Module

LED modules are made from a matrix of single LEDs mounted on one common carrier. In applications where the human eye will perceive the individual LED within the matrix the uniformity of the LEDs becomes important.

Color uniformity takes top priority due to the human eyes sensitivity to any color differences of LEDs in neighboring positions. The most common specification for color uniformity measurements is the color temperature specified in Kelvin. Also the spectral shape or color rendering index uniformity can be of interest. Luminous flux uniformity is not a high priority especially with high intensity LEDs. This is because the human eye is not able to compare intensities very well at higher intensity levels.

The measurement itself is done in the BTS256-LED snapshot mode where all the data from any measurements are stored in one ASCII file. At the end of the measurement the data can be imported into Excel or other available software for numeric or graphic presentation

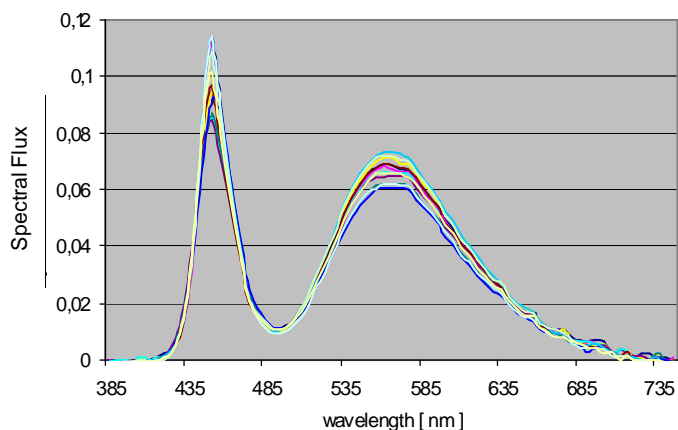

Uniformity of Spectral Flux

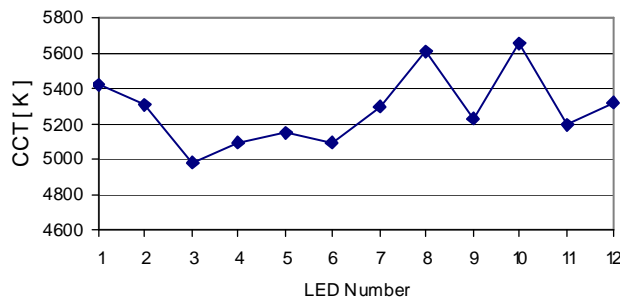

Uniformity of Color Temperature

	Ra	R1	R2	R3	R4	R5	R6	R7	R8	R9	R10	R11	R12	R13	R14
LED1	64,48	59,71	73,69	79,16	59,72	59,81	58,17	78,39	47,16	0,00	33,20	48,31	26,06	62,58	88,14
LED2	63,86	58,72	73,09	79,24	58,99	58,91	57,57	78,19	46,13	0,00	32,20	47,48	24,82	61,61	88,20
LED3	61,75	55,46	71,39	79,84	55,87	55,25	54,59	78,72	42,86	0,00	29,05	43,39	17,69	58,66	88,65
LED4	62,42	56,19	71,80	80,09	57,35	56,88	56,76	77,54	42,77	0,00	30,36	45,68	24,98	59,22	88,69
LED5	63,04	57,25	72,28	79,87	58,28	57,84	57,25	77,67	43,90	0,00	31,12	46,77	26,23	60,17	88,55
LED6	62,03	55,80	71,44	79,76	56,99	56,39	56,05	77,39	42,39	0,00	29,53	45,31	22,80	58,82	88,54
LED7	63,84	58,28	73,35	80,41	58,61	58,76	58,30	78,07	44,90	0,00	33,18	47,12	27,12	61,39	88,87
LED8	65,24	60,28	75,04	80,69	59,61	60,54	59,85	78,73	47,19	0,00	36,22	48,35	28,78	63,65	89,05
LED9	62,43	57,02	71,78	78,50	57,66	57,31	55,83	77,30	44,06	0,00	29,33	45,76	22,96	59,87	87,78
LED10	64,82	61,00	73,82	77,47	60,74	60,87	57,51	78,13	49,03	0,00	32,49	49,29	26,03	63,64	87,14
LED11	62,11	56,10	71,59	79,34	57,05	56,63	55,99	77,39	42,77	0,00	29,49	45,32	22,56	59,18	88,29
LED12	63,19	57,91	72,46	78,97	58,65	58,36	56,91	77,52	44,74	0,00	30,91	47,19	25,00	60,80	88,06

Tabular with Numerical Data of Color Rendering Index Uniformity (CRI Values in %)

Specifications BTS256-LED Tester	
Sensor Design	BiTech Sensor with fine photometric matching photodiode and 256 pixel CMOS photodiode array. Integrated shutter for remote controlled offset compensation.
Integral Sensor	Integration time setting from 100 $\mu$ s to 6s. Seven (7) measurement ranges with correction range transcendent offset correction. 12Bit SAE ADC
	Spectral response with fine CIE photometric matching. On-line correction by spectral source data
	Luminous flux resolution 0.1mlm; Max luminous flux value 10000lm
Spectral Sensor	Integration time setting from 5.2ms to 30s. Shutter delay 100ms open state, 100ms close state
	Spectral range 380 to 750nm. Pixel resolution 1.5nm. Other resolutions by interpolation or integration
	Luminous flux measurement range (white light):
	<ul style="list-style-type: none"> <li>Minimum signal 200mlm [With 30s maximum integration time a flux of about 4mlm](200mlm/30s) can be measured]</li> <li>Maximum signal 2500lm (5.2ms integration time)</li> </ul>
	Peak wavelength: +/- 1nm
	Dominant wavelength: +/- 1nm
	$\Delta$ x, $\Delta$ y reproducibility: Standard Illuminant A +/-0.0001, LEDs +/- 0.0002
	$\Delta$ x, $\Delta$ y uncertainty: Standard Illuminant A +/-0.005, LED +/- 0.005 average, max +/-0.01
	CCT Measurement range: 1700 to 17000 K
	$\Delta$ CCT: Standard Illuminant A 50K; LED up to +/-6K depending of LED spectrum
Color Rendering Index Ra and R1 to R14	
Integrating Sphere	50mm diameter with ODM98 coating. Sealed window at sphere output port. Cone adapter with rugged type ODP97 coating. Cone adapter measurement aperture diameter 10mm.
	White LED auxiliary lamp. AUX LED delay 1ms. LED current peak max 350mA capacitance supported
	Cone adapter exchange effect within +/- 0.5%
	xy DUT position error within cone adapter max. +/- 2%
	z axis DUT position error within cone adapter max. +/-2% (1 to 11 mm)
Microcontroller	16Bit, 25ns instruction cycle time
Power	5VDC to 7VDC, 250mA peak during aux lamp capacitance loading
Remote interface	RS232: 115200Baud, 8D, IS, N; 9PIN SUBD connector with PIN for DC voltage USB to RS232 converter with DC voltage transfer function from PC USB PC software with software manual
Temperature	Operating: 10 to 30 $^{\circ}$ C Storage: -10 to 50 $^{\circ}$ C
Dimensions/Weight	160mm (6.3 in) L x 85mm (3.3) W x 60mm (2.4 in) H. Weight: 500g (1.1 lb)

### Specifications: BTS256-LED Tester Accessory

UMBB-210-BTS256-LED 210mm diameter integrating sphere 1)	Measurement range integral sensor: ca. 5mlm to 50000lm <sup>2</sup> )
	Spectral sensor: ca. 160mlm to 130000lm <sup>2</sup> ) @ diode array measurement time 30s to 5.2ms
	Max measurement port diameter 63.5mm / 2.5 inch Port reducer 50.8mm / 2 inch diameter (used for calibration purpose)
UMBB-500-BTS256-LED UMBB-500-HF-BTS256-LED 500mm diameter integrating sphere 1)	Measurement range integral sensor: ca. 25mlm to 250000lm <sup>2</sup> )
	Spectral sensor: ca. 1lm to 650000lm <sup>2</sup> ) @ diode array measurement time 30s to 5.2ms
	Max measurement port diameter 127mm / 5 inch Port reducer 75mm / 3 inch diameter (used for calibration purpose)
BTS256-LED-DA Illuminance Adapter	Measurement range integral sensor: ca. 1lx to tbc lx; Spectral sensor: 10lx to tbc lx Cosine function within +/- 25 $^{\circ}$

1) All integrating spheres supplied with auxiliary lamp and traceable calibration of luminous flux and spectral flux sensitivity in combination with BTS256-LED with calibration certificate. The BTH-19-D-BTS256-LED power supply is recommended.

2) Maximum measurable flux is not only limited by detector and amplifier dynamic range. Heat generated by the source under test can also limit measurement range. Stated specifications exclude range limitations caused by varying ambient conditions!



**Dimensions: UMBB-210-LED256-LED**

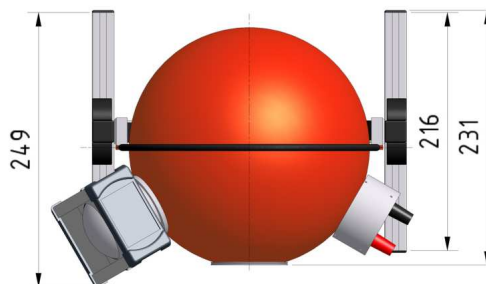
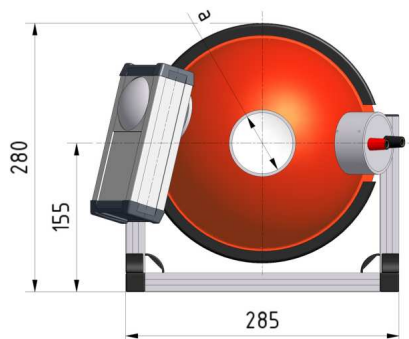

**Dimensions: UMBB-500-LED256-LED**

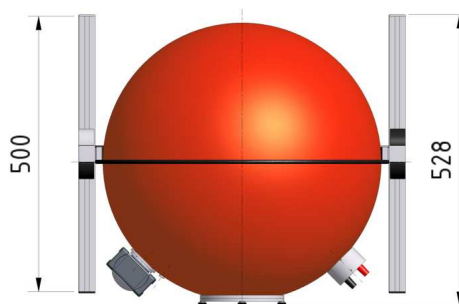
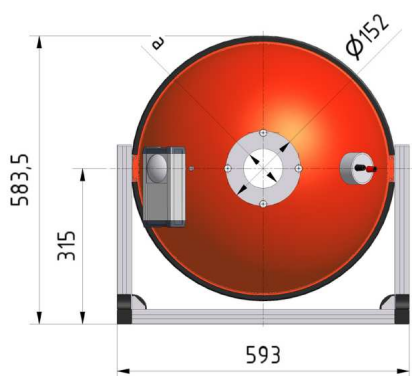

**Dimensions: UMBB-500HF-LED256-LED and Sample Holder UMSH-AP-500**

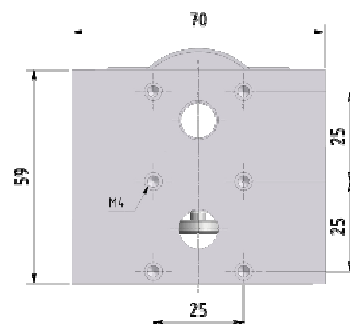
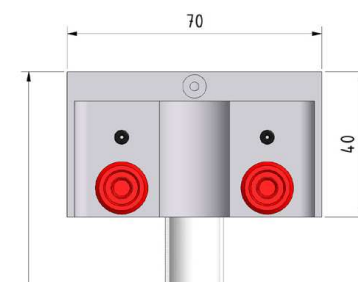
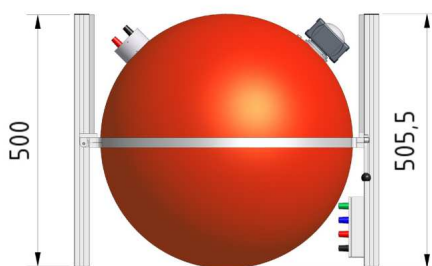
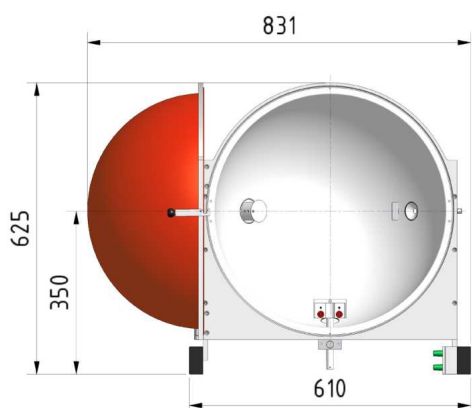



Gigahertz-Optik GmbH is a world class manufacturer of innovative UV-VIS-NIR optical radiation measurement instrumentation for specification critical industrial, medical and research application. Light gauges for transmission, reflection and fluorescence support material testing in service and production. Calibration standards supports customers on-site comparison of light detection and imaging sensors. Traceable calibrations are the basic reference to ensure quality for all light measurement instruments and calibration standards. The Gigahertz-Optik calibration laboratory for optical radiation quantities provides the most extensive range of calibrations available from industrial suppliers. For the measurement *spectral responsivity* and *spectral irradiance* Gigahertz-Optik is accredited by the Deutscher Kalibrierdienst (DKD) as calibration laboratory according to ISO/IEC 17025 since 1993 with registration number DKD-K-10601.

### **Products and Services**

Light and Luminous Color Meter  
Light Analyzer for Lamp and LED Testing  
Light Meter for Pulse Shape Analysis  
Goniophotometer  
UV-A, UV-B and UV-C Radiometer  
UV Germicidal Light Meter  
UV Hazard Light Meter  
Light Transmission Spectrophotometers  
Integrating Spheres for Light Measurements  
Integrating Spheres for Reflection and Transmission Measurements  
Integrating Sphere Measurement Systems  
Integrating Sphere Light Sources  
Optical Diffuse Material (OP.DI.MA.)  
Barium Sulfate Paint  
Catalogue Products  
OEM and Custom Made Product Service  
Calibration Standards  
Calibration Laboratory for Optical Radiation Measurement Quantities  
Calibration Laboratory for Spectral Reflectance  
Calibration Laboratory for Spectral Transmittance  
DIN EN ISO/IEC 17025 accredited Calibration Laboratory DKD-K-10601 since 1993

[www.gigahertz-optik.com](http://www.gigahertz-optik.com)

**Headquarters: Gigahertz-Optik GmbH**

D-82170 Puchheim Germany - Postfach 1445  
Tel: +49 (0) 89 / 890159-0 Fax: +49 (0) 89 / 890159-50  
[info@gigahertz-optik.de](mailto:info@gigahertz-optik.de)

**USA & Canada: Gigahertz-Optik Inc.**

5 Perry Way - Newburyport MA 01950 - 4009 USA  
Tel: +978.462.1818 Fax: +978.462.3677 -  
[b.angelo@gigahertz-optik.com](mailto:b.angelo@gigahertz-optik.com)

**Local Sales Representative:**