

DM-1321 Encoder

MPEG-2 / MPEG-4 (H.264) Video Encoder



Description

The DM-1321 offers cost-effective, high-quality, real-time encoding of up to two high-definition (HD) or standard-definition (SD) analog video inputs to MPEG-2 or MPEG-4 H.264, in a compact 1RU 19" form factor. Audio can be encoded to Dolby AC3 or AAC-LC.

The default configuration of the DM-1321 accepts analog component video inputs (480i/480p/720p/1080i) and outputs MPEG-2 transport streams to either UDP or RTP over Gigabit Ethernet. Encoder settings can be configured remotely using SSH or a browser-based configuration utility, or locally using RS-232.



Benefits

- Migrate your MPEG-2 encoding solution to H.264 to improve bandwidth efficiency without a hardware upgrade
- Accepts standard- or high-definition video from two input sources
- Software upgradeable to support multiple coding formats and custom video applications*
- Ideal for space-constrained environments, can be wall or rackmounted

Target Applications

- Digital Program Distribution
- Remote Broadcast
- Networked Video
- IP Television
- Distance Education

Features

- Real-time encoding of up to two SD/HD analog channels to MPEG-2 or H.264 (user-selectable for each channel)
- Dolby Digital AC3 or AAC-LC stereo audio encoding (user-selectable for each channel)
- Two component video inputs with stereo audio inputs
- Two Gigabit Ethernet outputs
- Auto-sensing to detect video input/resolution (480i/480p/720p/1080i)
- MPEG-2 transport stream output over UDP/IP or RTP/UDP/IP (user-selectable for each channel)
- 1RU 19" rackmount form-factor
- Remote configuration via SSH or web-based GUI control
- Streaming of TS file from USB
- Dual redundant power supplies
- Optional Interfaces include*: SDI video input, ASI output, QAM RF output, DVB-parallel output



Figure 1. Example Usage for DM-1321 MPEG-2/H.264 Video Encoder

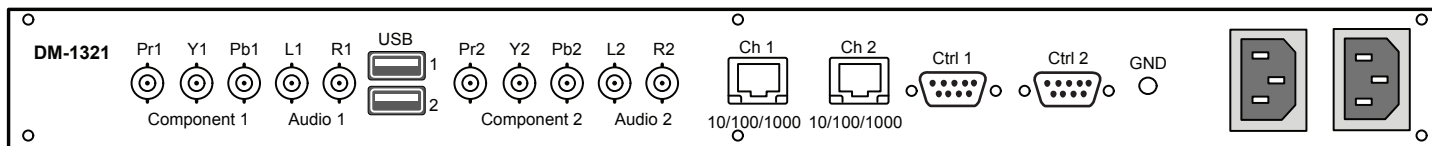

Figure 2. DM-1321 Back Panel (Connector layout may vary)

Specifications

[Video Processing]

- Video Input Interfaces
 - Component YPbPr (RCA Connectors)
 - USB Storage (playback of prerecorded MPEG TS files)
- Video Input Resolutions and Frame Rates (auto-sensing and reported via web-based GUI)
 - 480i (up to 30fps)
 - 480p (up to 30fps)
 - 720p (up to 60fps)
 - 1080i (up to 30fps)
- Video Encoding Formats
 - Chroma Subsampling: 4:2:2
 - HD: H.264 @ L4.0
 - SD: H.264 @ L3.0
 - HD: MPEG-2 MP @ HL
 - SD: MPEG-2 MP @ ML

[Audio Processing]

- Audio Input Interfaces:
 - Unbalanced analog stereo (RCA connectors)
- Audio Encoding Formats (user-selectable):
 - Dolby Digital (AC3)
 - MPEG (AAC-LC)

[Output Processing]

- ISO/IEC 13818-1 compliant MPEG-2 Transport Stream
 - Audio/Video Mux
 - Configurable PIDs and PCR interval
 - Adjustable constant bit rate (CBR)
 - Min. Video Rate: 1 Mbps
 - Max. Video Rate: 15 Mbps
- Transport Protocols (user-selectable):
 - UDP/IP
 - RTP/UDP/IP
 - Unicast and Multicast
- Output Interface
 - Gigabit Ethernet (RJ-45 Connector)

[Physical and Power]

- Form factor: 19" 1U rackmount
- Dimensions: 1.75" (H) x 19" (W) x 18" (D)
- 115 V/230 VAC, 50/60 Hz power
- Power Consumption: 60 W max, depending on options
- Dual redundant power supplies

[Environmental]

- Operational Temperature: 0°C to 40°C
- Storage Temperature: -20°C to 60°C
- Humidity: 5 to 95% non-condensing, operating

[Management Interfaces]

- Remote configuration via SSH or web-based GUI control via Ethernet
- Local configuration via RS-232
- Software upgradeable via Ethernet
- Remote logging via SysLog

[*Optional (Future) Processing]

- Transcoding MPEG-2 to MPEG-4 AVC HD/ H.264
- Transcoding MPEG-4 AVC HD/ H.264 to MPEG-2

[*Optional (Future) Input Interfaces]

- Composite (SD Only), S-Video (SD Only)
- SDI (SD or HD) with embedded audio
- HDMI

[*Optional (Future) Output Interfaces]

- QAM RF Output
- DVB-ASI Transport Stream Output
- DVB-SPI Output
- 8-bit parallel LVDS

[Ordering Information]

- 901-00056 DM-1321 MPEG-2/MPEG-4 H.264 Video Encoder

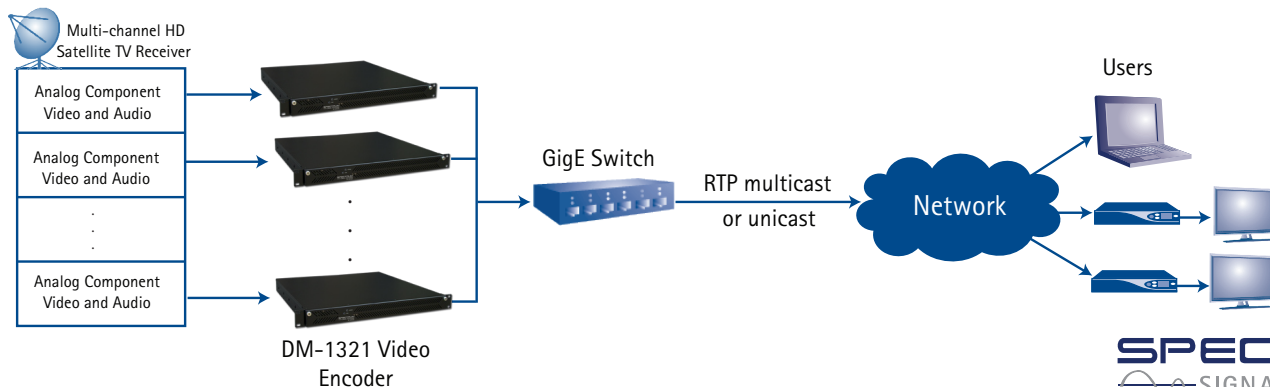

Figure 3. Example DM-1321 Multi-Channel System