

TrapBag

The logo graphic consists of a stylized black 'T' shape. The vertical stem of the 'T' is on the left. The horizontal bar of the 'T' is on the right and features a series of parallel diagonal lines sloping downwards from left to right. In the center of the horizontal bar, there is a brown, irregular shape representing a bag or container.

PRESS KIT

— Fargo, ND 2011 —



FOR IMMEDIATE RELEASE

Contact: Jessica Barton
(239) 481-5511, ext. 225
jbarton@spiroandassociates.com

FARGO SELECTS SENTINEL BARRIERS' TRAPBAGS® FOR EMERGENCY FLOOD LEVEE CONSTRUCTION

Fort Myers, Fla., company to provide 6 miles of flood barriers in 8 city locations

FARGO, N.D. (March 16, 2011) — The city of Fargo has contracted with Sentinel Barriers in Fort Myers, Fla., and AmeriGlobe in a joint venture to provide materials for temporary levees in eight areas of Fargo as the Red River of the North is expected to crest in the coming days. Sentinel Barriers will provide six miles of sand-filled or gravel-filled levees with its patent-pending TrapBags® system to prevent the river from flooding the Fargo area. Another one mile of work will be done for a Cass County government project. Sentinel Barriers will be training local workers March 17 and 18, and work will begin shortly thereafter. The projects are expected to be completed within seven days.

On March 3, the National Weather Service gave an 80 percent chance that the Red River will exceed last year's crest of 37 feet at Fargo and neighboring Moorhead, Minn., and a 35 percent chance it will surpass the record crest of 40.84 feet set in 2009, when water damaged 100 homes. TrapBags are designed to keep the river's water flowing in its natural path.

TrapBags are a series of 100-foot-long pentagon-shaped bags with a common flexible portion separating each individual cell. They are connected side by side like an accordion, with separate cells within, making it easy to deploy and store. Each cell is sloped on one side, vertical on the opposite side and open at the top for filling. For the Fargo project, 4-foot and 6-foot high TrapBags will be used.

TrapBags® are designed to be rapidly filled. The segments are hung on a guide rail system of a mobile delivery device where they are filled with sand or gravel (or other fill material) from a front-end loader, excavator or other heavy machinery. A tractor pulls the delivery system while the hopper is loaded to fill each cell. A crew of four can provide up to a .5-mile barrier in about 24 hours. For a 4-foot tall, 100-linear-foot wall, it would take about 7,800 traditional sandbags. The same can be accomplished with just 34 TrapBags.

MORE

P.O. Box 2030, Fort Myers, FL 33902 | 239.229.5285 | www.TrapBag.com | Fax: 239.997.1055

Patent Pending. A Product of Sentinel Barriers



2-2-2-2

SENTINEL BARRIERS TRAPBAGS

"TrapBags are considerably less labor-intensive and significantly more cost-effective and safer than other methods for providing barriers to prevent flooding," said Everett "Buzz" Waid, company president, founder and inventor of TrapBags. "City officials were impressed with how TrapBags work, especially on frozen ground where other systems tend to lean or move during a thaw."

The Red River has incised a shallow, sinuous valley across one of the flattest expanses of land in the world: the floor of Glacial Lake Agassiz. It has passed into flood stage at least once per year in most recent years. During most years, this flooding has been minor, however since the beginning of a wet climatic cycle in 1993, several of these floods have been devastating.

The National Weather Service is expecting a third consecutive year of major flooding in the Red River Valley area. Fargo officials are preparing protection for a crest of up to 42 to 43 feet. Flood stage for Fargo-Moorhead is 18 feet.

About Sentinel Barriers:

Sentinel Barriers President Everett "Buzz" Waid invented the TrapBags system after helping the town of Fort Myers Beach, Fla., recover from Hurricane Charley in 2004. TrapBags have also been proven effective in the Florida Everglades and for other major projects. The company has extensive experience in providing barrier protection, and is presently providing assistance to state departments of transportation for primary flashflood erosion protection and mudslide abatement, as well as bridge-foundation protection. Waid can be reached at 239.229.5285 and Buzz@TrapBag.com.

###



FREQUENTLY ASKED QUESTIONS

What is the fill rate per foot and per hour?

- 2-foot bag: 400 linear feet/hour, 2.6 cubic yards/minute
- 4-foot bag: 250 linear feet/hour, 3.7 cubic yards/minute
- 6-foot bag: 125 linear feet/hour, 3.5 cubic yards/minute



These installation rates are based on using one, 3-cubic yard loader or two, 1-cubic yard skid steer loaders moving an average of less than 3 yards per minute. The production of these pieces of equipment is based on them working at less than half capacity based on CAT Performance Handbook edition #30 for a 100-foot travel to fill source.

Typically how many workers are on an installation crew?

Generally four people per crew per delivery system.

How many linear feet are in each prepackaged section?

Each prepackaged unit contains 100 feet of barrier regardless of barrier height.



What materials may be used to fill TrapBags?

- Sand
- Gravel
- Crushed Road Base
- RAP (Recycled Asphalt Millings)
- Mill Slag
- Topsoil
- Sandy Clay
- Flowable Fill
- Ready Mix Concrete
- 6" Minus Riprap or River Stones



FREQUENTLY ASKED QUESTIONS



Can TrapBags be installed in standing or moving water?

Yes! As long as the delivery system will stand up on the bottom and be able to be advanced. Fill material must be able to reach the system via conveyors, dredge, excavator, concrete pump, etc. The system will install the TrapBag in moving water up to half the height of the cells. Rates exceeding 4 feet per second have not been tested.

Does TrapBag stack for greater height? Yes!





FREQUENTLY ASKED QUESTIONS

What are TrapBag dimensions?

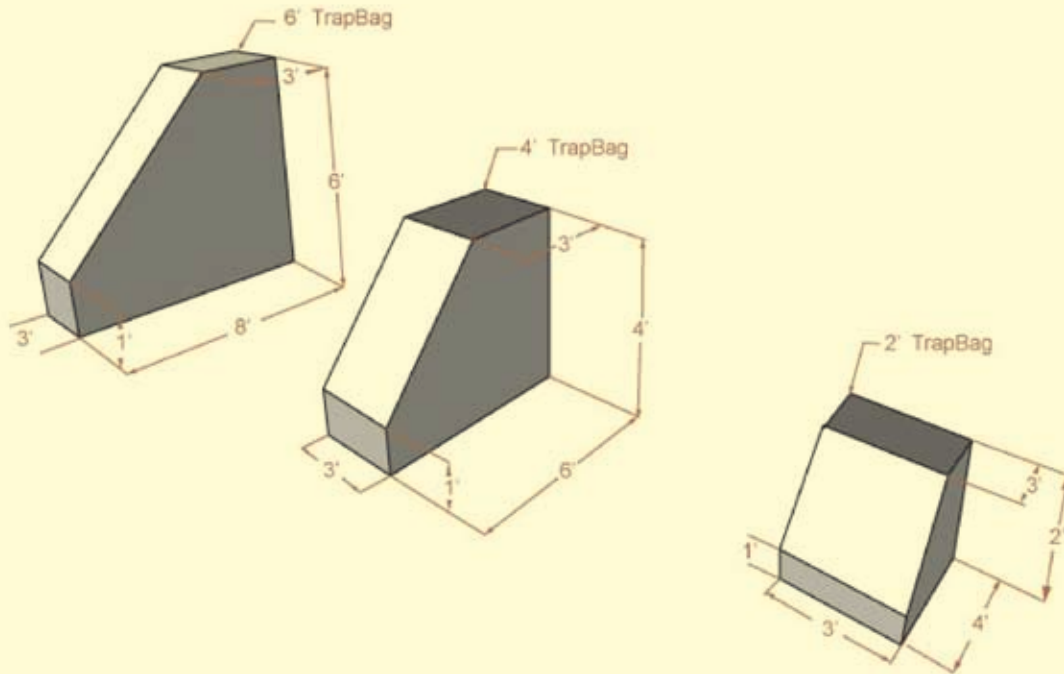

Will TrapBags install and work on uneven ground?

Yes, with the air suspension on the delivery system the TrapBag can be installed over small variations in the ground. However, the ground does need to be generally level.



What happens if water overtops the barrier?

This has happened; water was flowing 4 feet over the top for two days. The erosion from the open top was less than 4 inches and the bag never moved. The flow was about 20 feet per second at the peak 24 hours after the rain stopped.



FREQUENTLY ASKED QUESTIONS

Can TrapBags be installed on top of levees?

Yes, as long as there is material accessible. TrapBag system has a footprint of only 1.5 feet greater than the footprint of the bags themselves. Sentinel Barriers has a system designed to prevent over-topping of existing levees by using 2-foot TrapBags in conjunction with a mini-excavator and track dump trucks.

What is the delivery system?

The delivery system is a piece of equipment that during filling both supports the cells and holds them open. It also opens the next cells for filling as it is pulled forward.





ABOUT TRAPBAGS®

From Sentinel Barriers, Fort Myers, Fla.

TrapBags® are a system of barriers designed for rapid deployment to control floodwaters, mudslides, spills and other uses where a secure barrier is required. TrapBags are a continuous cellular barrier of pentagon-shaped bags, typically in 100-foot-long segments, and as tall as 6 feet and any height when stacked. These segments can be linked together to create barriers of any length. Once linked together the segments are filled with sand, crushed stone, concrete and other materials.

Uses Include:

Flood Control | Erosion Control | Mudslide Repair and Prevention
Pollution Spill Barrier | Gravity Wall | Replace Gabions Baskets
Levee Construction | Traffic Barrier | Security Barrier
Blast Wall | Beach Erosion | Coastline Protection

Traditional methods of handling these natural and man-made disasters become daunting tasks or become too costly to be practical.

TrapBags segments are hung on a guide rail system of a mobile delivery system where they are filled with sand or gravel (or other fill materials) from a front-end loader, excavator or other heavy machinery. A tractor pulls the delivery system while the hopper is loaded to fill each cell. A crew of four can provide up to a one-half-mile barrier in about 24 hours. For a 4-foot tall, 100-linear-foot wall, it would take about 7,800 traditional sandbags. The same can be accomplished with just 34 TrapBags.

For more information, please see the enclosed Frequently Asked Questions or call Sentinel Barriers President Everett "Buzz" Waid at 239.229.5285.



ABOUT AMERIGLOBE

AmeriGlobe is providing the containers for the joint-venture project of Sentinel Barriers and AmeriGlobe's 2011 levee construction in Fargo, N.D.

From the first day our business began in 1985, our vision was to make containers that meet the standards set by our customers. We are a company that lets the needs and expectations of our customers, from their own perspectives, guide the operations of our business. Our vision has never changed, though our product lines have. We have expanded to meet an ever-growing list of new challenges from AmeriGlobe customers: meeting those challenges with new designs, new products and new services.

The quality of AmeriGlobe's containers is ensured by strict quality control procedures that include UV testing machines, and 25 years of experience making containers. By placing AmeriGlobe employees at our foreign vendors' plants, AmeriGlobe also ensures that a container manufactured by one of our foreign vendors has the same quality as our U.S.-manufactured containers. AmeriGlobe offers a supply-line guarantee, making it a safe and wise choice for customers who want the peace of mind knowing they will receive their orders on time. Also, AmeriGlobe is C-TPAT Certified, which gives our customers' supply lines extra security. We are doing our part in the "greening" of the planet by providing customers with intelligent methods for re-using and recycling containers through our Container Refurbishing Center.

For more information, visit www.ameriglobe-fibc.com or call AmeriGlobe Co-presidents Dan Schnaars, Sr. at 337.280.9844 or Al Colby at 918.633.3728.



CONTACTS

Christopher Spiro, CEO

Spiro & Associates Marketing, Advertising & Public Relations

w: 239.481.5511, ext. 234 | m: 239.872.8311 | cspiro@spiroandassociates.com

Jessica Barton, Public Relations Director

Spiro & Associates Marketing, Advertising & Public Relations

w: 239.481.5511, ext. 225 | m: 239.691.2177 | jbarton@spiroandassociates.com

Joe Gonzales, Public Relations

Spiro & Associates Marketing, Advertising & Public Relations

w: 239.481.5511, ext. 232 | m: 239.292.4780 | jgonzales@spiroandassociates.com

Everett "Buzz" Waid

President, Sentinel Barriers | 239.229.5285 | buzz@trapbag.com

Dan Schnaars, Sr.

Co-president, AmeriGlobe | 337.280.9844 | dans@ameriglobe-fibc.com

Al Colby

Co-president, AmeriGlobe | 918.633.3728 | acolby@ictulsa.com

Danny Schnaars

Vice President, AmeriGlobe | 337.280.4734 | daniels@ameriglobe-fibc.com

Victor Althoff

Sales, AmeriGlobe | 219.561.1323 | victora@ameriglobe-fibc.com

TrapBag

The logo graphic consists of a thick black vertical bar on the left side of the word 'TrapBag'. From the top of this bar, several parallel lines extend to the right, passing through the 'a' and 'g' of 'Bag'. These lines are black on the outside and white on the inside, creating a sense of depth and movement. At the end of these lines, there is a brown, wavy shape that resembles a bag or a piece of fabric.

P.O. Box 2030, Fort Myers, FL 33902
239.229.5285 | www.TrapBag.com
Fax: 239.997.1055

Patent Pending. A Product of Sentinel Barriers