

THE ONLY 0.8V/0.6μA RAIL-TO-RAIL OP AMP

FEATURES

- Single 0.65V to 2.5V Operation
- Supply current: 0.6μA (typ)
- Offset voltage: 0.5mV (typ)
- Low TCV_{OS}: 20μV/°C (max)
- A_{VOL} Driving 100kΩ Load: 90dB (min)
- Unity Gain Stable
- Rail-to-rail Input and Output
- No Output Phase Reversal
- 5-pin SC70 Package

APPLICATIONS

- Battery/Solar-Powered Instrumentation
- Portable Gas Monitors
- Low-voltage Signal Processing
- Nanopower Active Filters
- Wireless Remote Sensors
- Battery-powered Industrial Sensors
- Active RFID Readers
- Powerline or Battery Current Sensing
- Handheld/Portable POS Terminals

DESCRIPTION

The TS1001 is the industry's first and only single-supply, precision CMOS operational amplifier fully specified to operate at 0.8V while consuming less than 0.6μA supply current. Optimized for ultra-long-life battery-powered applications, the TS1001 is Touchstone's first operational amplifier in the "NanoWatt Analog™" high-performance analog integrated circuits portfolio. The TS1001 exhibits a typical offset voltage of 0.5mV, a typical input bias current of 25pA, and rail-to-rail input and output stages. The TS1001 can operate from single-supply voltages from 0.65V to 2.5V.

The TS1001's combined features make it an excellent choice in applications where very low supply current and low operating supply voltage translate into very long equipment operating time. Applications include: nanopower active filters, wireless remote sensors, battery and powerline current sensors, portable gas monitors, and handheld/portable POS terminals.

The TS1001 is fully specified at V_{DD} = 0.8V and over the industrial temperature range (-40°C to +85°C). It is available in a PCB-space saving 5-lead SC70 surface-mount package.

TYPICAL APPLICATION CIRCUIT

A NanoWatt 2-Pole Sallen-Key Low Pass Filter

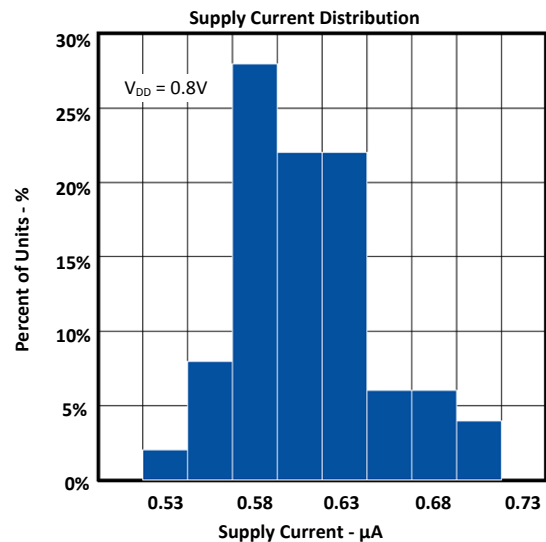
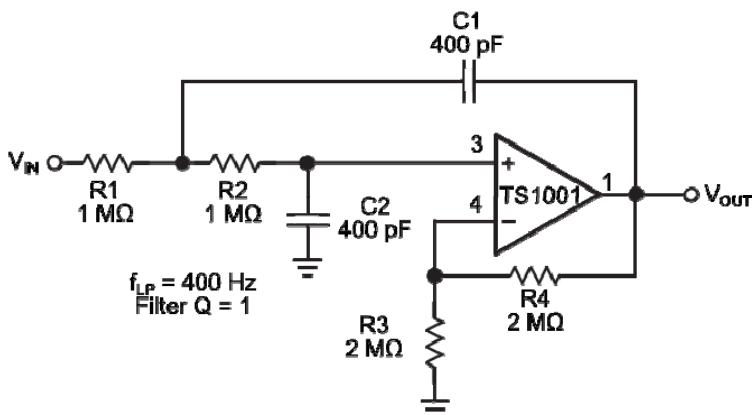

Patent(s) Pending

NanoWatt Analog and the Touchstone Semiconductor logo are registered trademarks of Touchstone Semiconductor, Incorporated.

PACKAGE/ORDERING INFORMATION

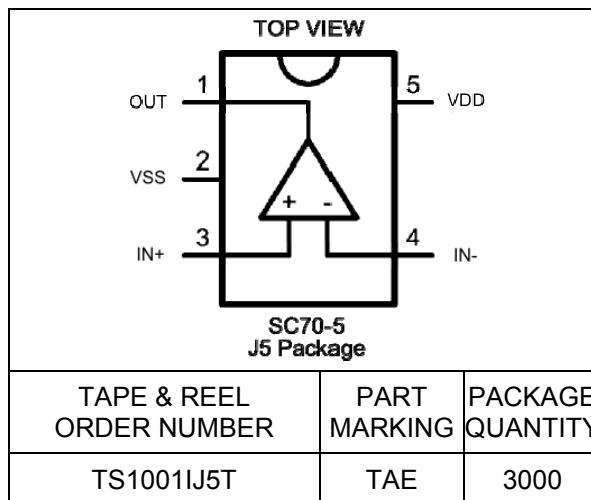

Lead-free Program: Touchstone Semiconductor supplies only lead-free packaging.

Consult Touchstone Semiconductor for products specified with wider operating temperature ranges.

Information furnished by Touchstone Semiconductor is believed to be accurate and reliable. However, Touchstone Semiconductor does not assume any responsibility for its use nor for any infringements of patents or other rights of third parties that may result from its use, and all information provided by Touchstone Semiconductor and its suppliers is provided on an AS IS basis, WITHOUT WARRANTY OF ANY KIND. Touchstone Semiconductor reserves the right to change product specifications and product descriptions at any time without any advance notice. No license is granted by implication or otherwise under any patent or patent rights of Touchstone Semiconductor. Touchstone Semiconductor assumes no liability for applications assistance or customer product design. Customers are responsible for their products and applications using Touchstone Semiconductor components. To minimize the risk associated with customer products and applications, customers should provide adequate design and operating safeguards. Trademarks and registered trademarks are the property of their respective owners.