

CIRALIGHT SunTracker 400

“We Speak Sun”
A Sustainable Lighting Solution

Specifications

Dimensions	51 x 51 x 26 in. (1295.4 x 1295.4 x 660 mm)
Roof Opening	46.5 x 46.5 in. (1181.1 x 1181.1 mm)
Net weight	58 lbs. (26.31 kg)
Base SunTracker Unit	
Dome	Extruded sheet of high impact, optically clear, acrylic or polycarbonate with UV protection <i>Light Transmissions:</i> ASTM D-1003, 91% at 0.125in. (3.175mm) thickness <i>Rockwell hardness:</i> ASTM D-785 (M Scale), 45 <i>Impact Strength:</i> ASTM D-256 (IZOD), 1.2 at 73 degrees F and 0.5 at 0 degrees F
Dome Frame	Leak proof extruded aluminum alloy type 6063 T5 welded, with dual condensation gutters, gaskets, and factory mounted airtight lens
GPS Controller	Solar powered GPS sun-tracking controller accurately calculates location and follows the sun's position regardless of weather or season
Mirror Options	<i>Single Mirror:</i> aluminum reflector coated with a super reflective Oxide-layer system on one side to reflect light / <i>Reflection:</i> ASTM: E-1651 (95%) <i>Triple mirror:</i> aluminum reflector coated with a super reflective Oxide-layer system on one side to reflect light / <i>Recommended for sites above 40° latitude N/S/ Reflection:</i> ASTM: E-1651 (95%)
Required Accessories	
Lightwell	Highly reflective regal white aluminum sheets of varying length
Diffuser Lenses	<i>Upper prismatic diffuser lens:</i> impact modified acrylic or polycarbonate lens mounted airtight at factory and located at top of lightwell in dome frame <i>Lower diffuser lens:</i> impact modified acrylic or polycarbonate options in varying shapes, located and sealed at the bottom of the lightwell
Optional Accessories	
Security Bars	Heavy duty steel round bar welded into grid to fit inside lightwell with 8in. (203mm) spacing throughout
Shade System	Motorized blackout shade, wireless or wall switch controlled; vsolar powered, electrical, or manual crank
Certifications	AAMA/WDMA/CSA 101/I.S.2/A440-05 Certified Florida Product Approval, Number FL #14468 OSHA Fall Protection (report #72202.01-109-44)





CIRALIGHT SunTracker 400 "We Speak Sun"

Product Brief

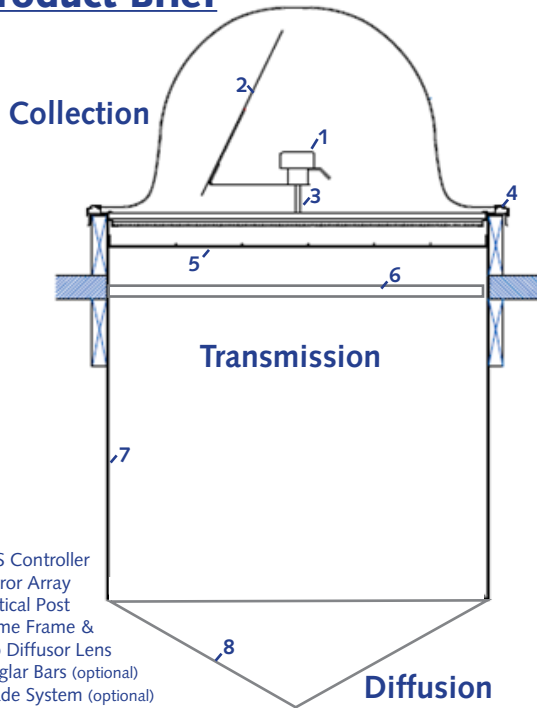

1. GPS Controller
2. Mirror Array
3. Vertical Post
4. Dome Frame & Top Diffusor Lens
5. Burglar Bars (optional)
6. Shade System (optional)
7. Highly Reflective Lightwell
8. Lower Diffusor Lens

Quick Install Instructions

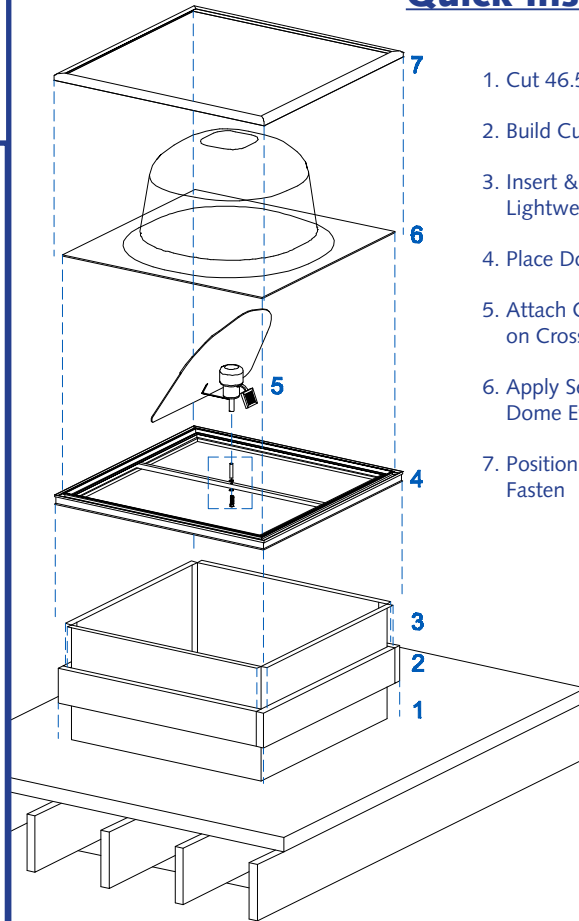

1. Cut 46.5" x 46.5" Rough Opening
2. Build Curb Around Opening & Flash
3. Insert & Seal Lower Diffuser Lens in Lightwell; Slide Lightwell Through Curb
4. Place Dome Frame on Curb; Fasten
5. Attach GPS Mirror Array to Vertical Post on Crossbar (See True South Detail)
6. Apply Sealant to Dome Edge; Position Dome Evenly on Dome Frame
7. Position Retaining Cap over Dome; Fasten

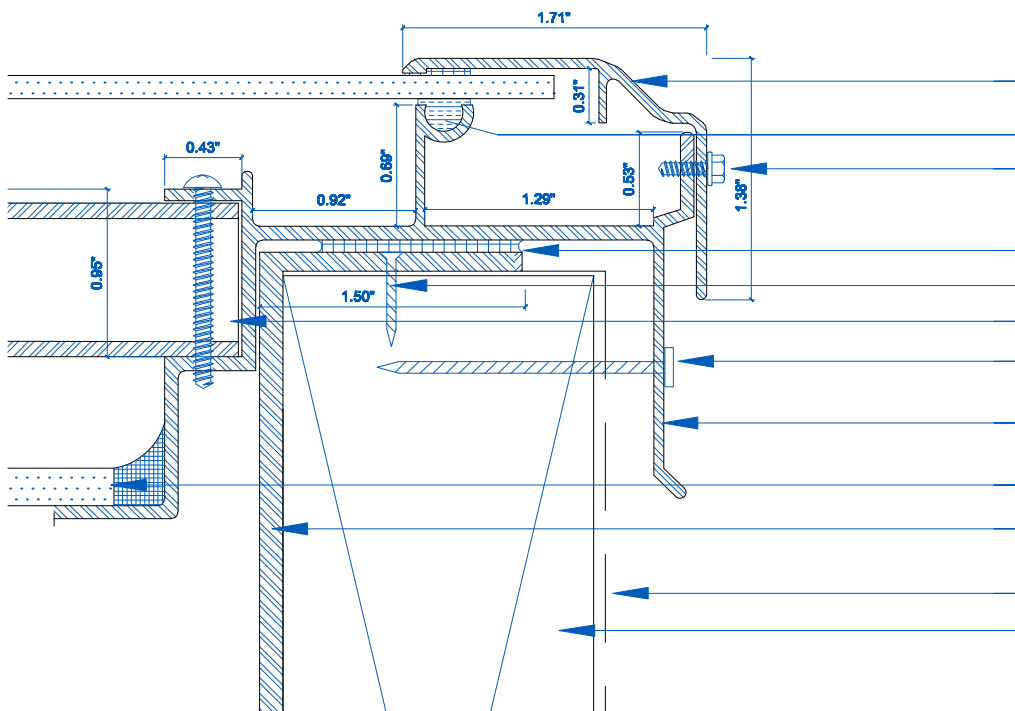
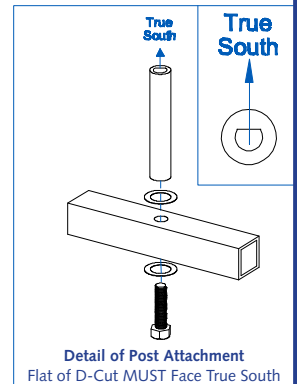

Curb Mount Detail

- 6063-T5 Aluminum Retaining Cap
Min. Thickness .062in. (1.57mm)
- Weather Stripping
- (4) 9/16in. (14.29mm) Screws per Side
No. 8 Zinc Plated Retaining Screw
- Foam Sealant Tape
- Retaining Screws for Lightwell
- 45.75in. (1,162.05mm) Crossbar
- (4) 1-1/2in. (38.1mm) Screws per Side
No. 10 Hex Head Zinc Plated
- 6063-T5 Aluminum Curb Frame
Min. Thickness .062in. (1.57mm)
- Upper Diffusion Lens
- Aluminum Lightwell
Min. Thickness .040in. (1.02mm)
- Flash and Shim (as necessary)
- Curb
- Silicone Sealant ----