

M7100 Industrial Pressure Transducer



- Rugged for heavy equipment and outdoor use
- Designed specifically for high volume applications
- Stainless Steel wetted surfaces
- Medium to extremely high pressures
- CE Approval

DESCRIPTION

The M7100 industrial pressure transducer from the Microfused™ line of MEAS sets a new price performance standard for demanding engine and vehicle industrial applications. This transducer is suitable for measurement of liquid or gas pressure, even for difficult media such as contaminated water, steam and corrosive fluids.

The transducer pressure cavity is machined from a solid piece of 17-4 PH stainless steel. The standard version includes a 1/4 NPT pipe thread allowing a leak-proof, all metal sealed system. There are no O-rings or organics exposed to the pressure media and the durability is excellent. This automotive grade pressure transducer with stainless steel hermetic pressure ports and integral electrical connector boasts up to 43,000psi (3000Bar). The M7100 exceeds the latest industrial CE requirements including surge protection and is overvoltage protected to 16Vdc in both positive and reverse polarity.

FEATURES

- Hermetic Pressure Ports
- Integral Electrical Connector
- Survives High Vibration
- 0.25% Accuracy
- Water Resistant 1M immersion

APPLICATIONS

- HVAC Refrigeration Controls
- Off Road Vehicle Engine Control
- Compressors
- Hydraulics
- Energy and Water Management

STANDARD RANGES

Range	psiG	Range	BarG
0 to 150	•	0 to 010	•
0 to 300	•	0 to 020	•
0 to 500	•	0 to 035	•
0 to 01K	•	0 to 070	•
0 to 03K	•	0 to 200	•
0 to 05K	•	0 to 350	•
0 to 10K	•	0 to 700	•

*For higher pressure ranges, please consult factory.

M7100 Industrial Pressure Transducer

PERFORMANCE SPECIFICATIONS

Supply Voltage: 5V

Ambient Temperature: 25°C (unless otherwise specified)

PARAMETERS	MIN	TYP	MAX	UNITS	NOTES
Supply Voltage	4.75	5.00	5.25	V	
Supply Current		4	10	mA	
Ratiometric Output	0.5		4.5	V	1
Minimum Load Resistance	10			KΩ	
Total Error Band	-1.0		1.0	%	3
Compensated Temperature	-20		+85	°C	
Operating Temperature	-40		+125	°C	
Storage Temperature	-50		+125	°C	
Insulation Resistance (500Vdc)	100			MΩ	4
Reverse Voltage			16	V	
Overvoltage Protection			16	V	
Short Circuit Protected		Yes			
Output Noise @ 1kHz		10		mV	
Response Time (10% to 90%)			1.0	ms	
Long Term Stability	-0.25		0.25	%Span/Year	
Frequency Response @ 1kHz			-3	dB	
Recommended Torque			81 lbf-ft		

Notes

1. Ratiometric to supply voltage.
2. Best fit straight line.
3. Over the compensated temperature range.
4. Between sensor body to any pins of connector.

ENVIRONMENTAL SPECIFICATIONS

Supply Voltage: 5V

Ambient Temperature: 25°C (unless otherwise specified)

PARAMETERS	MIN	TYP	MAX	UNITS	NOTES
Humidity (@40°C)			93	%RH	
Pressure Overload			2X	Rated	
Pressure Burst			5X	Rated	5
Pressure Cycle	10M			Cycles	
Media, Pressure Port	Fluids compatible with 17-4PH Stainless Steel				
Mechanical Vibration	20g, 10 ~ 2000Hz MIL-STD-810C, Method 810C, Curve L				
Mechanical Shock	Half-Sine, Peak: 50g, 11ms MIL-STD-202, Method 213B, Condition A				
Package Protection	IP67 (IEC60529)				

Notes

5. The maximum pressure that can be applied to a transducer without rupture of either the sensing element or transducer.

M7100 Industrial Pressure Transducer

Agency Approvals

IEC61000-4-2 Electrostatic Discharge Immunity: 8kV Contact; 15kV Air; 3 Discharges; Class B. Unit survived

IEC61000-4-3 EM Field Immunity: 100V/m, 80MHz~1GHz, 255 MHz steps, 3s Dwell. Max recorded output error $<\pm 1.5\%$

IEC61000-4-4 Electrical Fast Transient Immunity: 1kV (Level 2), 120s, 5kHz Repetition Rate. Class B. Max recorded output error $<\pm 1.5\%$

IEC61000-4-5 Surge: 1kV (Level 2), L-L 500V, L-E 1kV. Class B. Max recorded output error $<\pm 1.5\%$

IEC61000-4-6 Conducted Immunity: 10V/140dB, 150kHz~80MHz (Level 3). Class B. Max recorded output error $<\pm 1.5\%$

IEC61000-4-9 Pulsed Magnetic Field Immunity: 100A/m (Level 3). Class B. Max recorded output error $<$

IEC55022 Emission: Class A, 40dB 30-220MHz, 47dB 230MHz-1GHz

Pressure Port Options

	Dim C (inches) [mm]
2 = 1/4-19 BSP Male	.52 [13.2]
4 = 7-16-20 UNF Male SAE J514, O-Ring Buna-N 70SH-904, ID8.92mm x W1.83mm	.52 [13.2]
5 = 1/4-18 NPT	.52 [13.2]
6 = 1/8-27 NPT	.52 [13.2]
P = 7/16-20UNF Female w/ Integral Valve Depressor	.65 [16.4]

Others available upon request

M7100 Industrial Pressure Transducer

DIMENSIONS

DIMENSION ARE IN INCHES [mm]

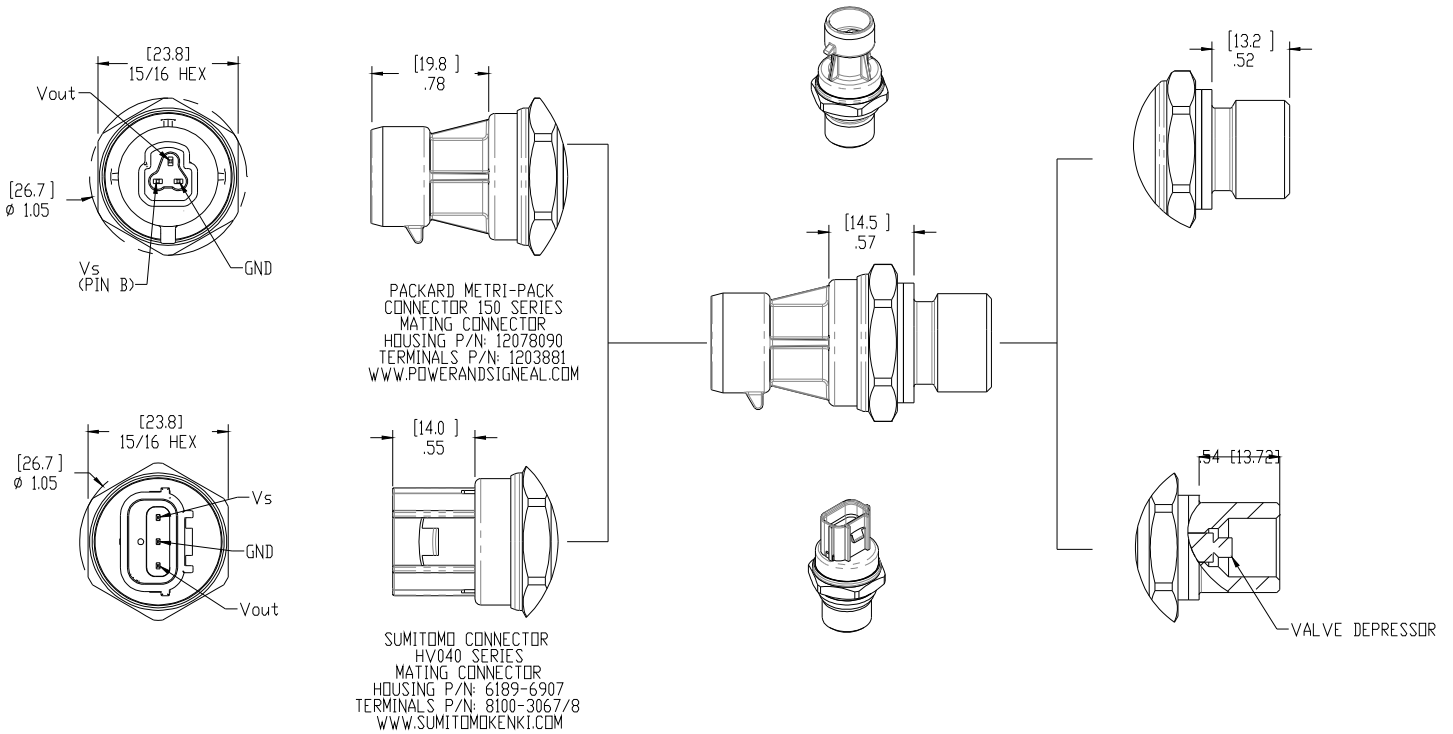

M7100 Industrial Pressure Transducer

ORDERING INFORMATION

M7134-300PG-200000

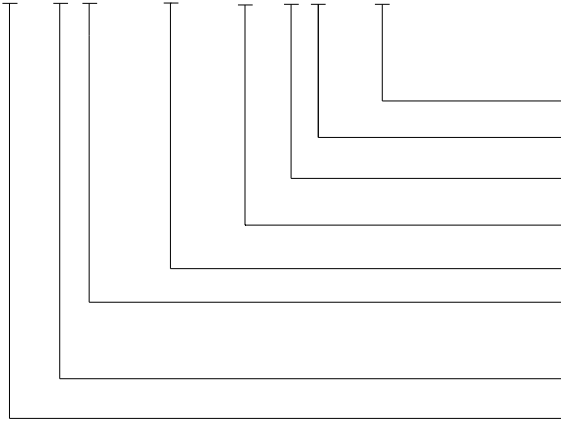

Specials (nnnn = Custom Drawing)
 Port Material (0 = 17-4PH SST)
 Pressure Port (See Pressure Port Options Table)
 Type (G = Gage)
 Pressure Range (See Pressure Range Table)
 Connection (8 = Sumitomo Connector,
 9 = Packard Connector [Supply; PIN B])
 Output (3 = 0.5 - 4.5V)
 Model

NORTH AMERICA

Measurement Specialties
 45738 Northport Loop West
 Fremont, CA 94538
 Tel: 1-800-767-1888
 Fax: 1-510-498-1578
 Sales: pfg.cs.amer@meas-spec.com

EUROPE

Measurement Specialties
 (Europe), Ltd.
 26 Rue des Dames
 78340 Les Clayes-sous-Bois, France
 Tel: +33 (0) 130 79 33 00
 Fax: +33 (0) 134 81 03 59
 Sales: pfg.cs.emea@meas-spec.com

ASIA

Measurement Specialties
 (China), Ltd.
 No. 26 Langshan Road
 Shenzhen High-Tech Park (North)
 Nanshan District, Shenzhen 518057
 China
 Tel: +86 755 3330 5088
 Fax: +86 755 3330 5099
 Sales: pfg.cs.asia@meas-spec.com

The information in this sheet has been carefully reviewed and is believed to be accurate; however, no responsibility is assumed for inaccuracies. Furthermore, this information does not convey to the purchaser of such devices any license under the patent rights to the manufacturer. Measurement Specialties, Inc. reserves the right to make changes without further notice to any product herein. Measurement Specialties, Inc. makes no warranty, representation or guarantee regarding the suitability of its product for any particular purpose, nor does Measurement Specialties, Inc. assume any liability arising out of the application or use of any product or circuit and specifically disclaims any and all liability, including without limitation consequential or incidental damages. Typical parameters can and do vary in different applications. All operating parameters must be validated for each customer application by customer's technical experts. Measurement Specialties, Inc. does not convey any license under its patent rights nor the rights of others.