

# BMW MINI-COOPER DYNAPRO ROAD RACE FRONT HAT KIT

## Models Covered:

BMW Mini-Cooper	2002-Present
BMW Mini-Cooper "S"	2002-Present

## Kit Features:

- Designed for use with 15" diameter road race wheels
- Full bolt-on installation
- Compatible with OE master cylinder output and ABS

## Component Features:

### DynaPro Four Piston Radial Mount Calipers

- Rigid FEA designed billet body provides maximum clamping efficiency and unyielding pedal response by eliminating fluid volume displacement loss from structural deflection at the high output pressures generated by power brake master cylinders
- Four stainless steel pistons generate high clamping force and balanced pad loading with reduced heat transfer and high resistance to corrosion.
- Quick-Clip pad retainers allow fast and easy pad service without caliper removal from the mount.
- Spring loaded stainless steel SRS bridge plates reduce noise by damping engagement harmonics and stopping pad rattle. Bridge wear from gouging at the pad trailing edge is also eliminated.
- Internal fluid passages prevent all potential problems associated with external fluid transfer tubes.
- Four corner bleed screws accommodate effective gas evacuation regardless of mounting position.
- Radial mounting provides solid attachment with two planes of adjustment for precise alignment and simplified caliper service in the field.

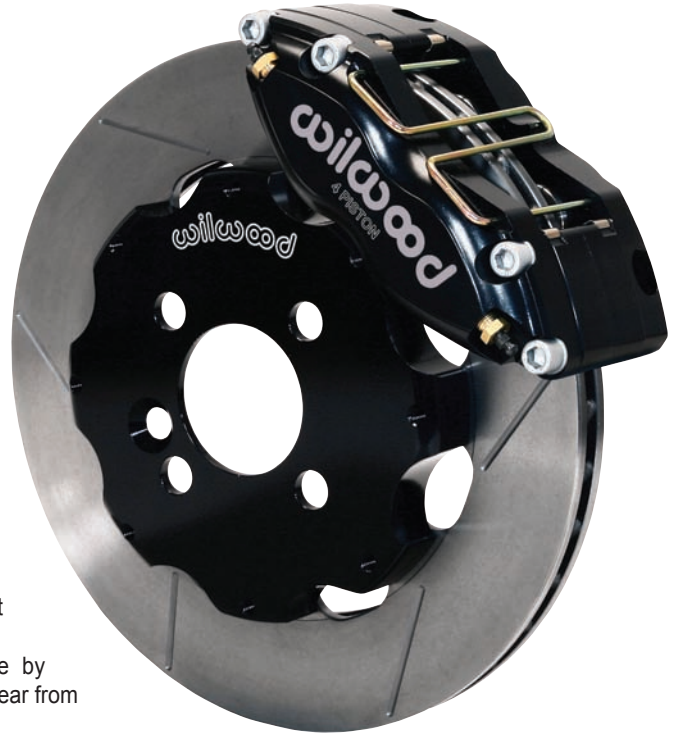

**BMW Mini-Cooper Road Race  
Front Kit with GT Rotor**

### HD-36 Series 11.75" Diameter Directional Vane Rotors

- 11.75" diameter 36 directional vane design provides high cooling efficiency with increased stopping leverage over OE diameter rotors.
- Premium grade long-grain carbon iron castings concentrate the rotor mass in the pad sweep face sections for maximum thermal stability in sustained high heat competition.

### Forged Aluminum Rotor Mounting Hats

- Premium grade alloy forged aluminum hats are lightweight and provide sturdy mounting of the vented iron rotors over the OE hub assembly.
- Weight savings realized by using the two-piece iron rotor with aluminum hat assembly improves acceleration and handling through reduced rotating and unsprung weight.

### PolyMatrix Brake Pads

- "E" compound brake pads provide positive response at low and medium temperatures for confident braking in the early laps, after restarts, or the first turn after a long cool-down straight stretch.
- A smooth rising friction curve with fade free performance to 1000° F provides consistent performance and pedal response in the hot sections of the track.
- Long wear and low rotor abrasion compliment the positive pedal response and wide temperature range of this compound.

### Mounting Hardware and Plumbing

- Machined billet radial mount brackets with all necessary high strength fasteners, washers, and alignment shims are included with each kit.
- Optional flex line kits include stainless steel reinforced teflon hoses with machine crimped ends and the fittings necessary to connect the calipers to the OE brake line fitting at the chassis. Flex line kits must be ordered separately.

**Please check the diagram on the back of this page for minimum inside wheel clearance requirements**

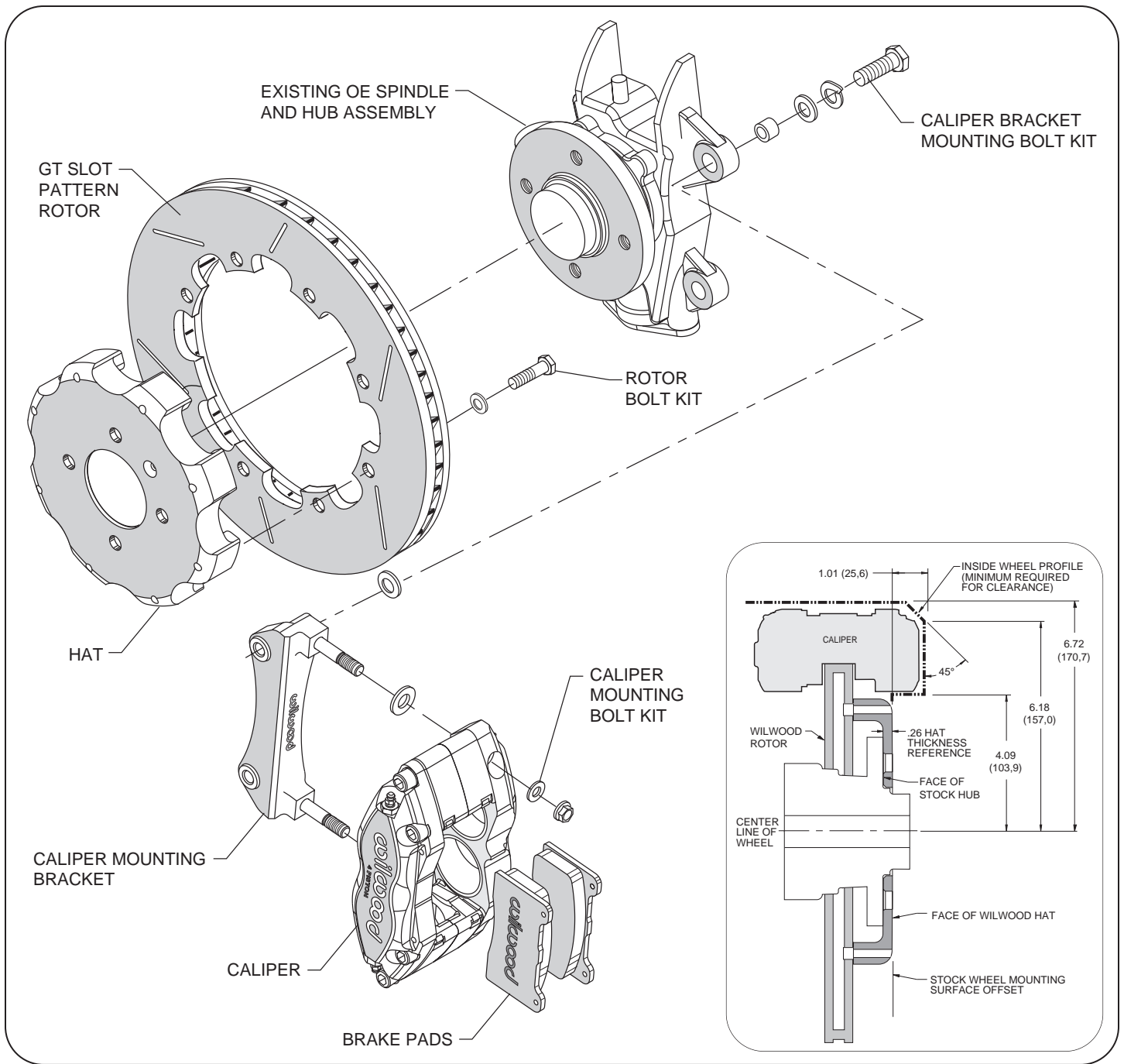

Typical Installation Diagram, Major Components Identified. Minimum Wheel Fit Dimensions Shown Inset

**ORDERING INFORMATION: BRAKE AND FLEX LINE KITS:**

<u>MAKE / MODEL</u>	<u>YEAR</u>	<u>KIT PART NUMBERS</u>	<u>FLEX LINE KITS</u>
BMW Mini-Cooper	2002-Present	<u>GT ROTOR RACE KIT</u> 140-8740	220-8491

**ORDERING INFORMATION: USER SERVICEABLE COMPONENTS, PART NUMBER:**

<u>KIT NUMBER</u>	<u>CALIPER</u>	<u>PAD SET</u>	<u>ROTOR</u>	<u>HAT</u>	<u>ROTOR BOLT KIT</u>	<u>MOUNT BRACKET</u>	<u>MOUNT BRACKET BOLT KIT</u>	<u>INSTALLATION SHEET</u>
140-8740	120-8538	15E-7266K	160-7701/02	170-8645	230-8390	250-8694	230-8692	DS-492