

## DYNAPRO REAR DRAG RACE KITS WITH LUG-DRIVE DYNAMIC MOUNT ROTORS

### Kit Highlights:

- Lug driven, dynamic mount stainless alloy rotors provide the most reliable, accurate, durable, warp resistant, low-drag, and trouble free rear axle drag kits ever offered.
- Single caliper models for four wheel disc cars, and dual mount caliper models for rear axle only brake systems on dragsters, provide the ultimate in stopping power, performance and safety.

### Component Features:

#### DynaPro Forged Billet Calipers

- Forged and machined from premium grade billet alloy, DynaPro calipers are the class of the field generating high clamping force with long service life from four corrosion resistant and heat retardant stainless steel pistons.
- Quick-E-Clip pad retainers, four-corner bleed screws, and replaceable SRS bridge plates simplify caliper and pad service and add to their long term durability.

### Lug-Drive Dynamic Mount Rotors and Hats

- The lug-drive rotor mounting system eliminates the rotor bolts and allows the rotors to move independently of the hats as they expand and contract through heat cycles.
- All thermally generated stress is removed from the rotor attachment points. The rotors stay flatter and run truer. Brake response and pedal feel remain consistent. Pad knock back and rotor drag are eliminated. The hats are no longer distorted by stresses generated by thermal expansion and shrinkage of the rotors. All problems associated with thermal distortion, including bolt hole alignment issues when trying to re-install new rotors on a previously used hat, are eliminated.
- Spring-loaded, replaceable stainless steel inserts in each lug-drive slot protect the aluminum hat from wear that would otherwise be caused by loading of the stainless steel rotor against the hat when brake torque is applied.
- A large, single internal snap-ring retains the rotor in the hat, making assembly and installation literally a snap. There is no longer any need to torque or safety wire rotor mounting bolts. The internal snap ring, as opposed to an external ring, provides increased security the faster the rotor spins.
- The already lightweight stainless alloy discs are additionally drilled to remove all unnecessary rotating weight from the driveline.

Single Caliper Kit Shown  
Download a High Resolution  
Photo for Printing, [click here](#)



### CM Compound Brake Pads • Type 7812-CM

- Composition Metallic pads are specially formulated for high temperature use with stainless steel and other special alloy rotors.
- CM pads provide positive response, long wear, and high friction without fade during high heat cycles at the end of the track.

### Mounting Brackets and Hardware

- Each caliper mount bracket is machined from a premium grade, heat treated aluminum alloy and features steel thread inserts for the highest degree of strength and reliability.
- High strength steel caliper mounting bolts, alignment shims, and all other necessary hardware are included.

**To view a short video to see how easy this assembly is, please click here:**

<http://youtu.be/wL4Fiwx1ES8?hd=1>

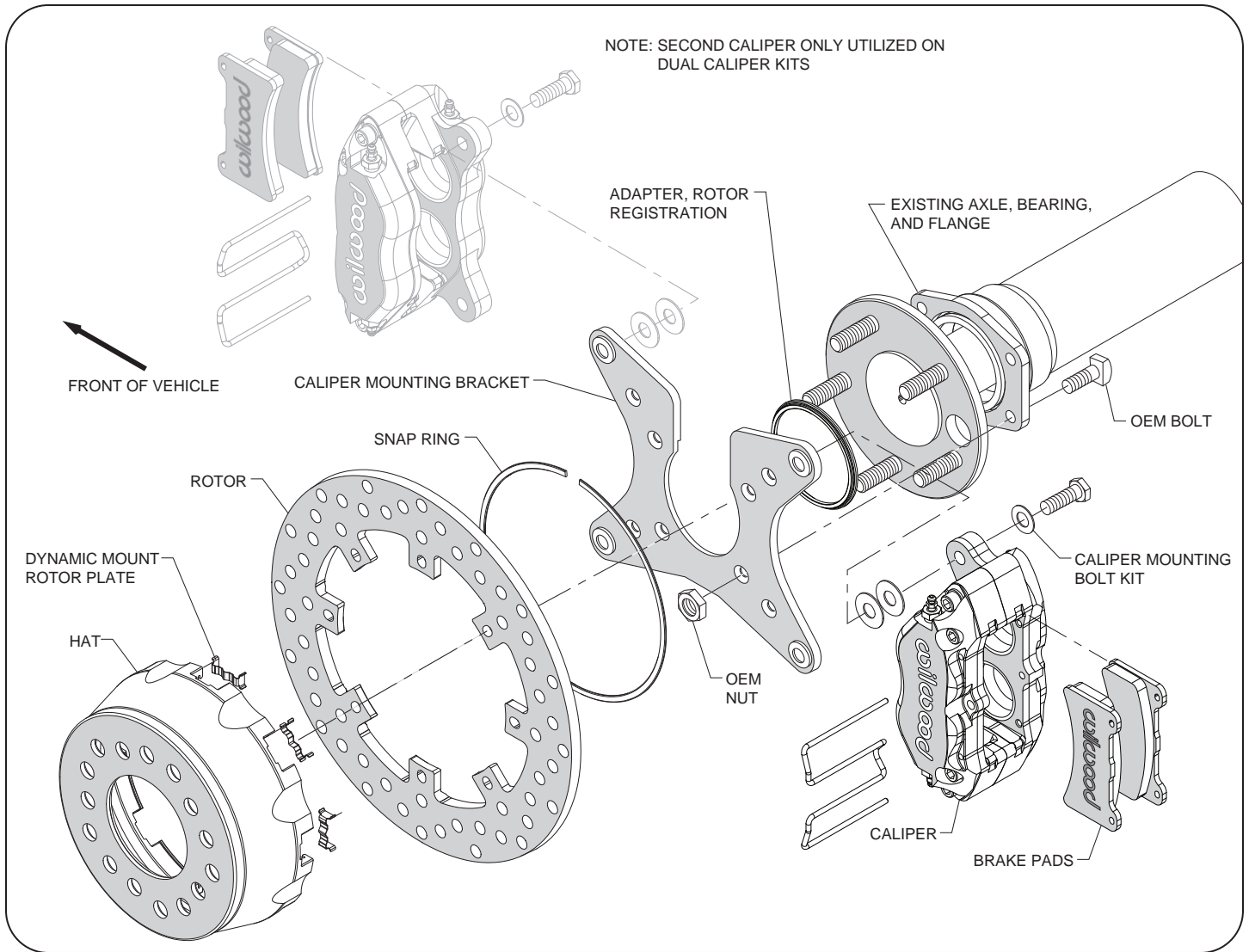

**Typical Installation Diagram, Major Components Identified**

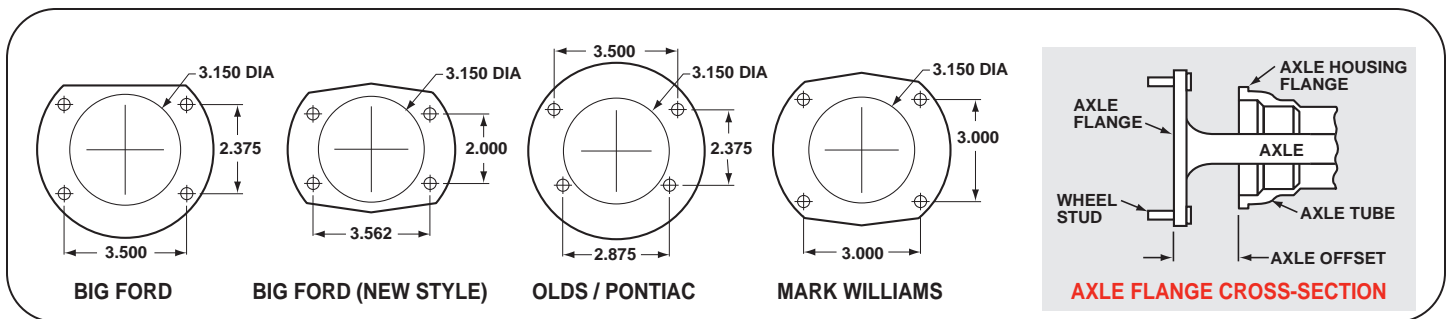

**Rear Housing Flange Chart and Axle Flange / Offset Cross-Section**

**ORDERING INFORMATION:**

<u>MAKE / MODEL</u>	<u>FLANGE OFFSET</u>	<u>KIT PART NUMBER DRILLED ROTOR KIT</u>
Big Ford	2.36"	140-12547-D
Big Ford - Dual Caliper	2.36"	140-12553-D
Big Ford, New Style	2.50"	140-12546-D
Big Ford, New Style - Dual Caliper	2.50"	140-12552-D
Lamb / Mark Williams	2.81"	140-12549-D
Lamb / Mark Williams - Dual Caliper	2.81"	140-12555-D
Lamb / Mark Williams with .68" Studs	2.81"	140-12551-D
Lamb / Mark Williams with .68" Studs - Dual Caliper	2.81"	140-12557-D
Oldsmobile / Pontiac	2.81"	140-12548-D
Oldsmobile / Pontiac - Dual Caliper	2.81"	140-12554-D
Oldsmobile / Pontiac with .68" Studs	2.81"	140-12550-D
Oldsmobile / Pontiac with .68" Studs - Dual Caliper	2.81"	140-12556-D