

CHEVY/GMC SUV AND 1500 SERIES TRUCK W4AR REAR DISC BRAKE KIT

Models Covered:

All models with 6 lug wheels

1999-Present

Kit Features:

- Matched rear braking for TC 6 Front Big Brake Kits.
- Full bolt-on installation for vehicles originally equipped with rear discs.
- Retains use of factory park brake assembly.
- Fully compatible with ABS and OE master cylinder output.
- Designed for use on custom / modified vehicles with oversized wheel and tire upgrades.

Component Features:

W4AR Forged Billet Radial Mount Calipers

- Competition proven and fully detail machined forged billet body demonstrates superior strength and resistance to deflection and separation under high load.
- Differential bore four piston design generates big brake clamping force with balanced pad loading for even wear in all sustained high heat, high load conditions.
- W4AR calipers use stainless pistons to resist corrosion and reduce heat transfer from the pads.
- Spring loaded SRS bridge plates dampen noise and engagement harmonics while protecting the caliper bridge from wear by pad gouging.
- High temperature, fluid resistant high gloss black finish is standard, with red available as an order option.

SRP or GT Directional Vane 14.25" Rotors

- Big 14.25" diameter provides increased leverage for improved stopping power over all OE sizes.
- SRP directional drilled and slotted rotors enhance pad performance with consistent response by cleaning and venting gasses, dust, and burnt pad material. A proprietary black e-coat finish is applied to resist corrosion.
- GT disc/drum rotors are based on Wilwood's full competition style GT race rotor preparation. Asymmetrical face slotting, and precision detail machining with tolerances held under .001" for flatness, parallelism, and overall run-out, assure consistent pad response and smooth operation with the highest level of durability. The additional mass of this non-cross drilled version delivers improved thermal stability and is preferred for heavy load, sustained high temperature applications.

Wilwood BP-10 "Smart Pads"

- All kits include BP-10 metallic-composite compound "Smart Pads". BP-10 delivers the increased friction; higher fade resistance, and longer wear of an entry-level track pad, with virtually noise and dust free performance for the street.
- Optional race-only compounds can be ordered to suit the braking requirements at all levels of severe duty and sustained high heat competition.

Radial Mounting Hardware and Plumbing

- Radial mounting provides secure attachment directly to the OE mount with two planes of adjustment for precise alignment over the rotor. Brackets, premium grade fasteners, and alignment shims are included in each kit.
- Stainless steel braided competition flex line kits, with machine crimped ends and the fittings necessary to connect the calipers with the OE chassis bulkhead, are available and must be ordered separately.



**Big Brake Rear Kit with SRP Rotor
and Red Caliper**

Download High Resolution Photo,
[Click Here](#)

NOTE
SPECIFIC PARTS MAY VARY FROM DIAGRAM

WARNING
INSTALLATION OF THIS KIT SHOULD **ONLY** BE PERFORMED BY PERSONS EXPERIENCED IN THE INSTALLATION AND PROPER OPERATION OF DISC BRAKE SYSTEMS.

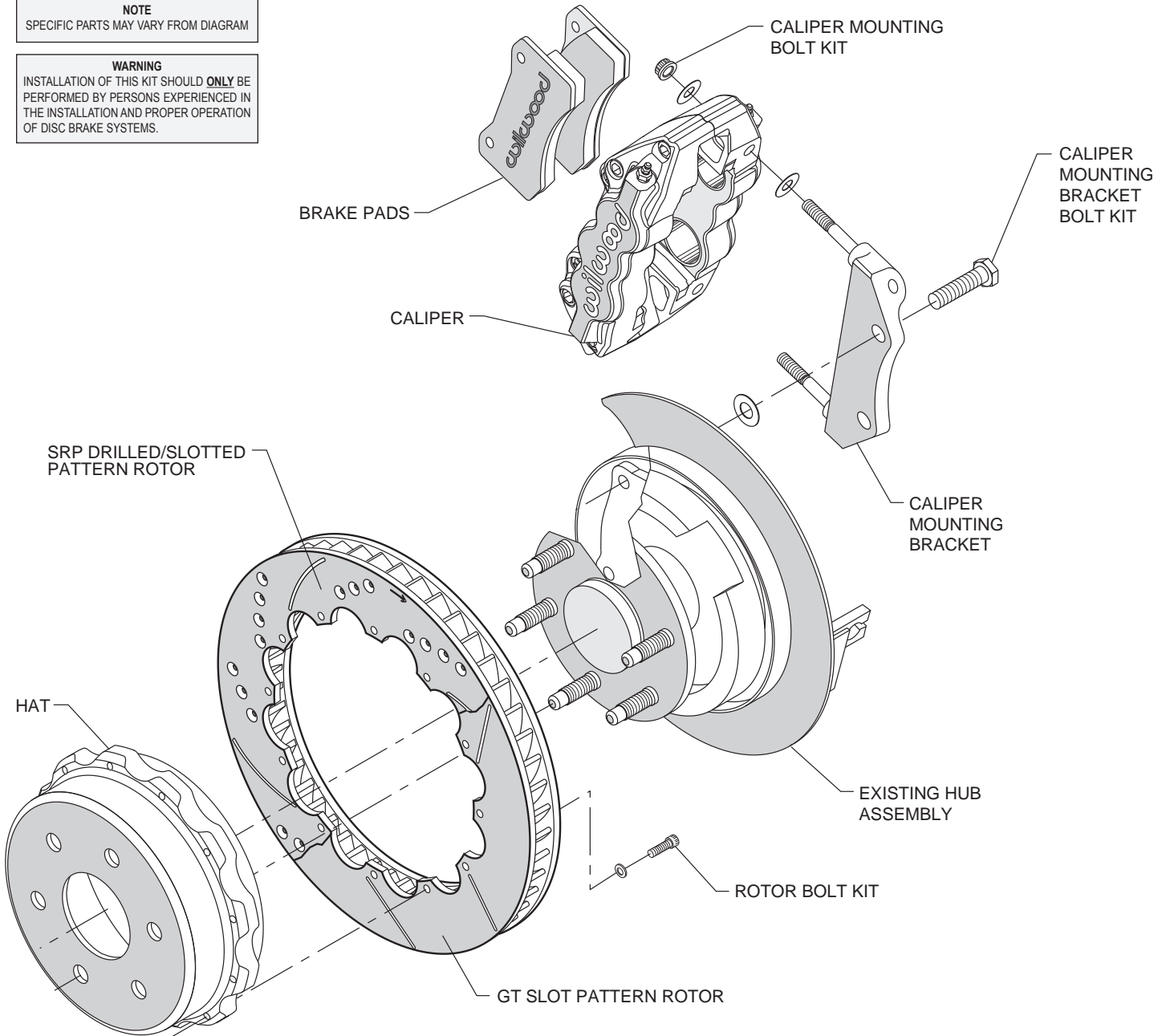

Typical Installation Diagram

ORDERING INFORMATION:

<u>PART NUMBER</u>	<u>DESCRIPTION</u>
140-9407	KIT, REAR, GM TRUCK / SUV 1500, 1999-UP, W4A, 14.25 ROTOR
140-9407-D	KIT, REAR, GM TRUCK / SUV 1500, 1999-UP, W4A, 14.25 ROTOR, DRILLED
140-9407-DR	KIT, REAR, GM TRUCK / SUV 1500, 1999-UP, W4A, 14.25 ROTOR, DRILLED, RED
140-9407-R	KIT, REAR, GM TRUCK / SUV 1500, 1999-UP, W4A, 14.25 ROTOR, RED