



BOMAG
FAYAT GROUP

Tandem Vibratory Roller BW90AD-5, BW100ADM-5



Clear operation and indicator controls with a new ergonomic steering wheel for maximum comfort.



Wind screen protected water spray nozzles with integrated filter provides uniform coverage.



Maintenance free bolt on articulated / oscillating joint.



Technical Specifications

BW90AD-5, BW100ADM-5

Shipping dimensions in cubic feet (m³)	without	/	with ROPS
BW90AD-5	120.5 (3.4)		170.7 (4.8)
BW100ADM-5	133.1 (3.8)		188.5 (5.3)

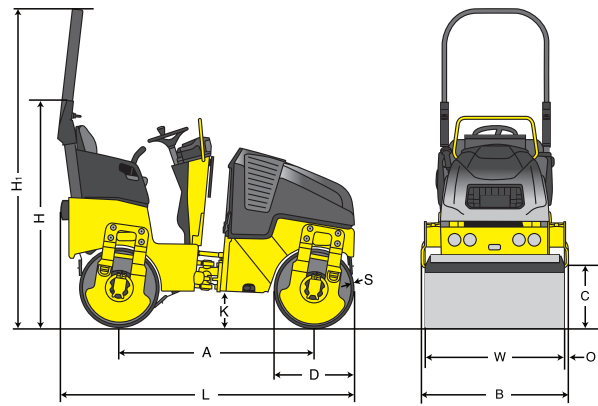

Standard Equipment

- Hydrostatic travel and vibration drives
- Front and rear drum vibration
- Front or rear drum vibration lockout
- Series travel drive
- ROPS with retractable seat belt
- Bolt-on oscillating / articulation joint
- Crab walk 0-2in (0-50mm)
- Hydrostatic articulated steering
- Spring-Applied, Hydraulically Released (SAHR) parking brake
- Vibration control in travel lever
- Intelligent Vibration Control (IVC)
- 2 scrapers per drum
- Plastic water tank
- Pressurized water sprinkler system
- Hour meter
- Display with control and warning indicator lights
- Fuel level indicator
- Lockable vandal protected instrument panel and engine hood
- Front, center and rear transport lift points
- Emergency stop button
- Corrosion and weather protected ignition switch
- Back-up alarm
- Adjustable operator seat
- Seat contact switch
- Manual storage
- Working lights front and rear

Optional Equipment

- Foldable ROPS
- Service kit

Dimensions in inches (mm)

	A	B	C	D	H	H ₁	K	L	O	S	W
BW90AD-5	58.4 (1483)	37.6 (956)	17 (433)	22.8 (580)	64.1 (1627)	90.7 (2304)	10 (255)	86.4 (2194)	1.1 (28)	0.5 (12)	35.4 (900)
BW100ADM-5	58.4 (1483)	41.6 (1056)	17 (433)	22.8 (580)	64.1 (1627)	90.7 (2304)	10 (255)	86.4 (2194)	1.1 (28)	0.5 (12)	39.4 (1000)

Technical data

Weights

Operating Weight.....	lbs (kg)	3527 (1600)
Average axle load.....	lbs (kg)	1764 (800)
Average static linear load CECE.....	pli (kg/cm)	49.8 (8.9)

Driving Characteristics (depending on site conditions)

Speed (with vibration).....	mph (kmph)	0-2.8 (0-4.5)
Speed (for transport).....	mph (kmph)	0-6.2 (0-10)
Max. gradeability (without/with vibration)	%	40/30

Drive

Engine manufacturer.....		Kubota
Type.....		D902
Emission standard.....		Tier 4
Cooling - cylinders		water
Number of cylinders		3
Performance ISO 14396.....	hp (kW)	20.2 (15.1)
Speed	rpm	3000
Electric Equipment	V	12
Drive System.....		hydrostatic
Drum Driven.....		front + rear (Series)

Brakes

Service brake.....		hydrostatic
Parking brake.....		SAHR

Steering

Steering system.....		oscil., artic.
Steering method.....		hydrostatic
Track Radius, inner	in (mm)	79.9 (2030)
Steering angle ±.....	degrees	33
Oscillating angle ±	degrees	8

Vibratory system

Vibrating drum		front + rear
Drive system		hydrostatic
Frequency	vpm (Hz)	3780 (63)
Amplitude.....	in (mm)	0.020 (0.5)
Centrifugal force (each drum).....	lbs (kN)	3822 (17)

Water Spray System

Type of water spray system		pressurized
----------------------------------	--	-------------

Capacities

Fuel.....	gal (l)	7.9 (30)
Water.....	gal (l)	26.4 (100)

Technical modifications reserved. Machines may be shown with options.

BOMAG BW90AD-5

Operating Weight.....	lbs (kg)	3527 (1600)
Average axle load.....	lbs (kg)	1764 (800)
Average static linear load CECE.....	pli (kg/cm)	49.8 (8.9)

Speed (with vibration).....	mph (kmph)	0-2.8 (0-4.5)
Speed (for transport).....	mph (kmph)	0-6.2 (0-10)
Max. gradeability (without/with vibration)	%	40/30

Engine manufacturer.....		Kubota
Type.....		D902
Emission standard.....		Tier 4
Cooling - cylinders		water
Number of cylinders		3
Performance ISO 14396.....	hp (kW)	20.2 (15.1)
Speed	rpm	3000
Electric Equipment	V	12
Drive System.....		hydrostatic
Drum Driven.....		front + rear (Series)

Service brake.....		hydrostatic
Parking brake.....		SAHR

Steering system.....		oscil., artic.
Steering method.....		hydrostatic
Track Radius, inner	in (mm)	79.9 (2030)
Steering angle ±.....	degrees	33
Oscillating angle ±	degrees	8

Vibrating drum		front + rear
Drive system		hydrostatic
Frequency	vpm (Hz)	3780 (63)
Amplitude.....	in (mm)	0.020 (0.5)
Centrifugal force (each drum).....	lbs (kN)	3822 (17)

Type of water spray system		pressurized
----------------------------------	--	-------------

Fuel.....	gal (l)	7.9 (30)
Water.....	gal (l)	26.4 (100)

BOMAG BW100ADM-5

Operating Weight.....	lbs (kg)	3638 (1650)
Average axle load.....	lbs (kg)	1819 (825)
Average static linear load CECE.....	pli (kg/cm)	46.2 (8.3)

Speed (with vibration).....	mph (kmph)	0-2.8 (0-4.5)
Speed (for transport).....	mph (kmph)	0-6.2 (0-10)
Max. gradeability (without/with vibration)	%	40/30

Engine manufacturer.....		Kubota
Type.....		D902
Emission standard.....		Tier 4
Cooling - cylinders		water
Number of cylinders		3
Performance ISO 14396.....	hp (kW)	20.2 (15.1)
Speed	rpm	3000
Electric Equipment	V	12
Drive System.....		hydrostatic
Drum Driven.....		front + rear (Series)

Service brake.....		hydrostatic
Parking brake.....		SAHR

Steering system.....		oscil., artic.
Steering method.....		hydrostatic
Track Radius, inner	in (mm)	78 (1980)
Steering angle ±.....	degrees	33
Oscillating angle ±	degrees	8

Vibrating drum		front + rear
Drive system		hydrostatic
Frequency	vpm (Hz)	3780 (63)
Amplitude.....	in (mm)	0.016 (0.4)
Centrifugal force (each drum).....	lbs (kN)	3822 (17)

Type of water spray system		pressurized
----------------------------------	--	-------------

Fuel.....	gal (l)	7.9 (30)
Water.....	gal (l)	26.4 (100)