

GENERAL

The ZRT Series Zone Control Exhaust Terminals by American ALDES are designed to introduce flexibility and dynamic control to central ventilation systems. Used in both large and small systems, the ZRT regulates ventilation without the need for individual fans. Each ZRT is a combination grille, register box, control damper, and optional flow regulator(s). This unique combination provides up to four different control schemes without the need for expensive pneumatic, electronic, or DDC control systems.

By replacing static grilles in large central exhaust systems, the ZRT-1 model provides on-off control for on-demand ventilation. This allows central fan downsizing and promotes energy savings by minimizing necessary fan horsepower and ventilation-induced heat and cooling loads on the building. The optional model CAR-II Constant Airflow Regulator can be installed in the ZRT-1's extended duct collar to place a maximum flow limit on each terminal. Automatic operation of the CAR-II will prevent noise and excessive energy consumption caused by over-ventilation, as well as fluctuations in airflow rates as total system pressure varies.

The ZRT-2 model can also be used for combination low-flow indoor air quality ventilation and on-demand high-flow spot ventilation using the same central fan system. This is achieved by integrating a CAR-II minimum airflow controller directly into the damper subassembly. With the damper completely closed, the factory-calibrated CAR-II will still allow steady low continuous ventilation during fan operation (consult the CAR-II specifications sheet for sizing and specifying information). When other ZRT terminals are opened for on-demand control of spot ventilation, the closed ZRT-2s will maintain the specified low continuous rate through the CAR-II minimum flow control. By opening the ZRT-2's control damper, the low-flow regulator is removed from the air stream, allowing either controlled (optional using a second CAR-II) or full maximum-boost ventilation.

The ZRT series terminals can themselves activate fans used in smaller central exhaust ventilation systems. Through the use of an

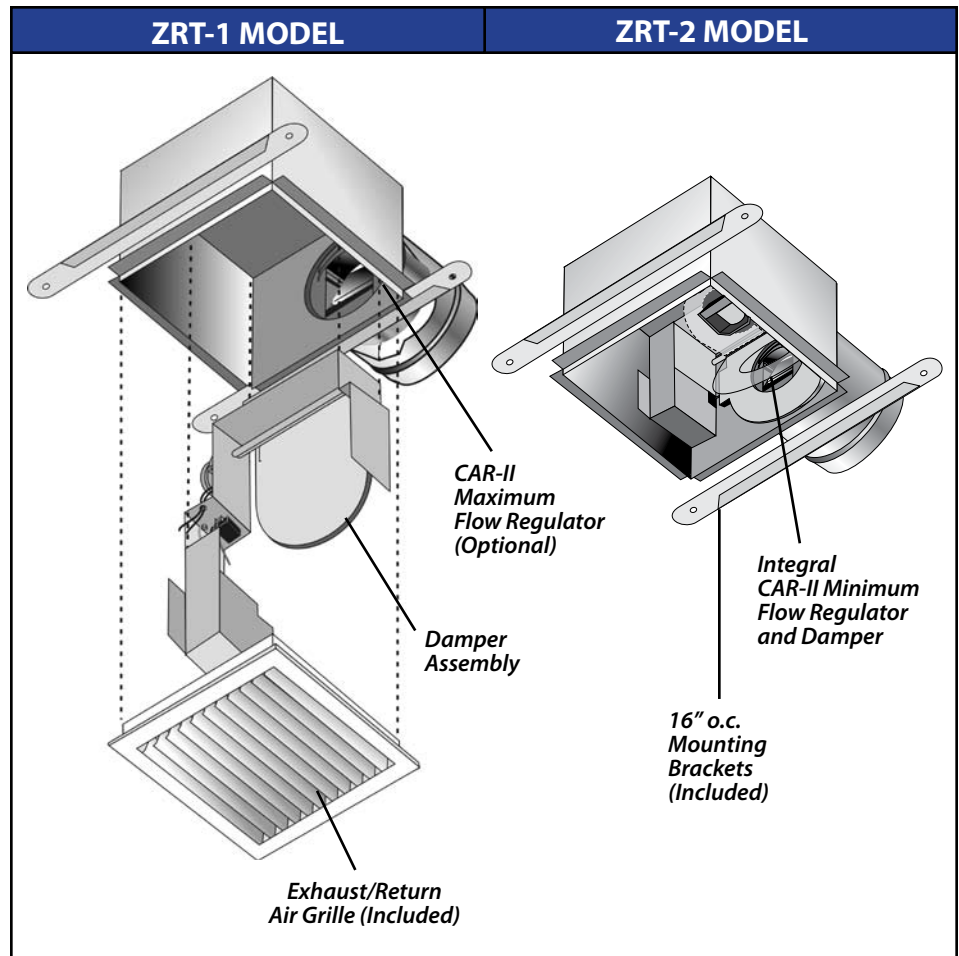

ZRT DIMENSIONAL DATA

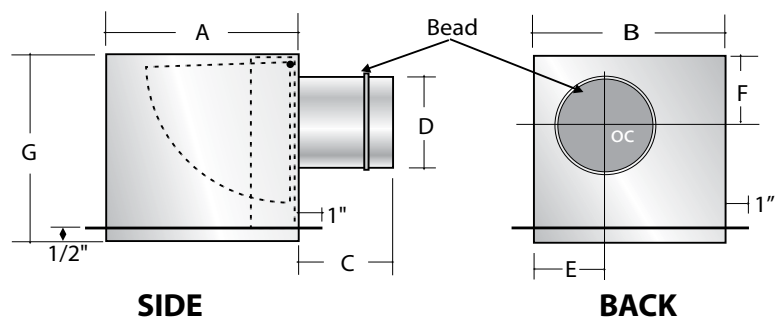

SIZE	A	B	C	D	E	F	G
4"	8"	8"	4-1/2"	3-7/8"	3"	3"	7"
6"	10"	10"	5-1/2"	5-7/8"	4"	4"	8-1/2"

integral damper end-switch, the ZRT can trigger the remote fan to start. This provides the distinct advantage of allowing the fan to only ventilate specific spaces when called upon, without the need for separate fans in each space. This is especially important in residential bath exhaust applications using popular inline and multi-port fans, where low noise and a single exterior vent penetration are desired.

CONSTRUCTION

All ZRT Zone Control Exhaust Terminals are constructed of a heavy-gauge galvanized steel housing for durability. The units are designed for installation in all ceiling types, with an overall height that allows location between floors using 10 inch or larger joist construction. The extended duct collar allows for simple attachment to rigid or flexible ducting, and insertion of an optional CAR-II constant airflow regulator for maximum flow control. An integral steel mounting flange assembly encapsulates the ceiling opening and allows simple attachment of American ALDES all-aluminum or steel flush-mount grilles.

The damper assembly is provided with a long-life 24V or 120VAC actuator motor with spring return. An optional damper end-switch is available to control signaling of a remote fan to activation. The gasketed tight seal damper blade prevents air leakage and noise in the closed position. A solid through-blade damper shaft that pivots on permanently lubricated bearings is used to support the blade assembly and to prevent deflection caused by motor torque and exposure to air velocity. The entire damper assembly can be installed or removed from below the register box without disconnecting the duct or removing the box from the ceiling.

CONTROL

The ZRT series terminals can be activated using a variety of control options, including: on-off or timer switches, dehumidistats, occupancy sensors, or time-clock switches. Any on-off control device(s) will signal the damper to go full open, allowing maximum ventilation control. Upon disconnecting the power, the ZRT's integral spring will

return the damper blade to its normally closed position.

A Zone Terminal Fan Control Center (model ZTC) is available for use with 24V zone terminals.

Airflow control for both maximum and minimum flow rates is achieved using optional integral dynamic constant air regulators (CAR-II). The CAR-II is an automatic modulating orifice that regulates airflows to constant levels in response to duct pressure. They require no additional power supply and are ideally suited for use in zone-controlled systems where duct pressures can fluctuate in response to the opening and closing of dampers.

MAINTENANCE

The ZRT needs no maintenance when used in normal conditions. If the intended application includes air heavily loaded with grease or dust, a filtered grille is recommended.

TYPICAL SPECIFICATION

Furnish and install model ZRT zone control exhaust terminals by American ALDES Ventilation Corporation or approved equal. The exhaust terminals shall be of sizes and capacities, and at locations scheduled on the drawings. The terminal casing shall be minimum 24-gauge G90 galvanized steel with integral duct collar that allows attachment of both rigid and flexible ducting. The collar shall be sized to allow full insertion of a model CAR-II constant air regulator for maximum flow control, but without the regulator extending into attaching duct. All 120V terminals must be listed per UL standards and carry the UL or ETL mark indicating compliance. Each ZRT terminal shall include all necessary mounting brackets and hardware.

The primary air volume mechanism shall be a single-blade damper operated by a long-life 24VAC or 120VAC disconnecting type drive motor with normally closed spring-return closure. When fully open, the damper shall rotate out of the air stream on a solid-through blade shaft and pivot on permanently lubricated bearings. A permanently fixed perimeter gasket seal shall be provided to prevent air noise and leakage at the closed position. The entire damper assembly and operable parts shall be capable of removal from the terminal housing from below without disconnecting duct or removing the housing.

Where indicated on the drawings or schedule, a minimum airflow modulating control device shall be incorporated into the damper assembly. The control device shall respond to changes in duct pressure to maintain specified flow rates at a constant level. The minimum airflow control device shall be calibrated at the factory. Mechanical damper stops are not acceptable. Where a maximum flow is indicated on the drawings and/or schedule, a model CAR-II constant air regulator shall be installed in the terminal's duct collar. VAV terminal units with analog electronic or direct digital controls may be used as an alternative.

Installation shall be per all applicable codes and manufacturer's instructions.

MODEL NUMBER SPECIFICATIONS

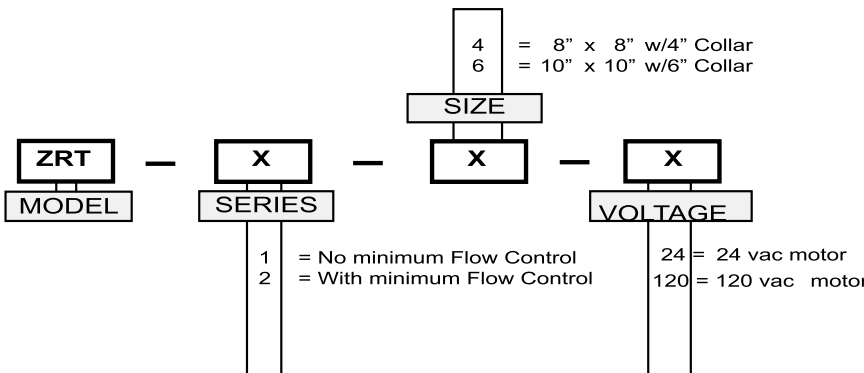

30 = 30 cfm	60 = 60 cfm
25 = 25 cfm	50 = 50 cfm
20 = 20 cfm	45 = 45 cfm
10 = 10 cfm	35 = 35 cfm
0 = 0 cfm	30 = 30 cfm
	25 = 25 cfm
	20 = 20 cfm
	10 = 10 cfm
	0 = 0 cfm
SIZE 4	
SIZE 6	
MINIMUM FLOW CONTROL CFM	
X	X
MAXIMUM FLOW CONTROL CFM	
SIZE 4	
SIZE 6	
0 = None	0 = None
20 = 20 cfm	75 = 75 cfm
25 = 25 cfm	90 = 90 cfm
30 = 30 cfm	105 = 105 cfm
35 = 35 cfm	125 = 125 cfm
45 = 45 cfm	140 = 140 cfm
50 = 50 cfm	160 = 160 cfm
60 = 60 cfm	175 = 175 cfm

ZRT ACOUSTIC PERFORMANCE

	AIRFLOW			0.2 In. w.g. (50 PA)			0.4 In. w.g. (100 PA)			0.6 In. w.g. (150 PA)			0.8 In. w.g. (200 PA)		
	CFM	M3/H	LPS	LW - dB (A)	LW - NR	LW - NG	LW - dB (A)	LW - NR	LW - NG	LW - dB (A)	LW - NR	LW - NG	LW - dB (A)	LW - NR	LW - NG
Damper Closed w / 4" Minimum Flow Control	10	15	4	24	22	21	28	25	24	31	28	26	34	30	29
	20	30	8	25	22	21	30	25	24	34	29	27	37	31	30
	25	45	13	27	24	22	32	26	25	35	30	28	38	32	31
	30	50	14	28	24	22	33	27	25	36	30	28	39	32	31
	35	60	17	31	28	26	37	33	30	38	33	31	42	36	35
	45	75	21	32	28	26	37	33	30	39	34	32	42	37	36
	50	90	25	32	29	26	38	34	31	40	34	33	44	40	38
Damper Open w / 6" Maximum Flow Control	60	100	28	34	30	27	39	34	32	41	35	34	43	41	39
	75	130	36	31	27	25	34	32	31	39	36	35	42	39	38
	90	150	42	33	28	27	37	34	33	41	37	35	45	39	38
	105	180	50	34	28	27	40	35	33	44	38	36	46	40	39
	125	210	59	34	29	28	40	36	34	42	37	35	44	38	37
	140	240	67	35	30	28	41	37	34	44	38	36	47	40	39
	160	270	76	37	31	29	43	38	35	45	39	38	49	43	41
175	300	84	38	32	30	44	39	36	46	41	39	50	44	42	

ZRT AIRFLOW REGULATOR PERFORMANCE

**ZRT-2-4
MINIMUM FLOW CONTROL
3" DIA. (80mm)**

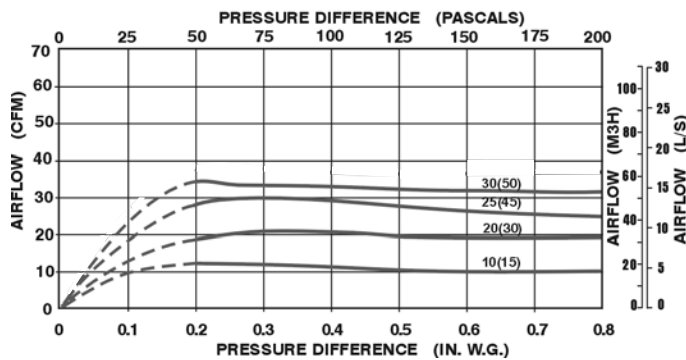

**ZRT-1-4 or ZRT-2-4
MAXIMUM FLOW CONTROL
ZRT-2-6 MINIMUM FLOW CONTROL
4" DIA. (100mm)**

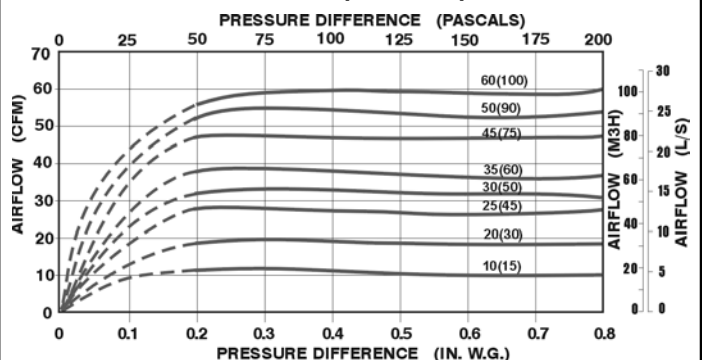

**ZRT-1-6 or ZRT-2-6
MAXIMUM FLOW CONTROL
6" DIA. (150mm)**

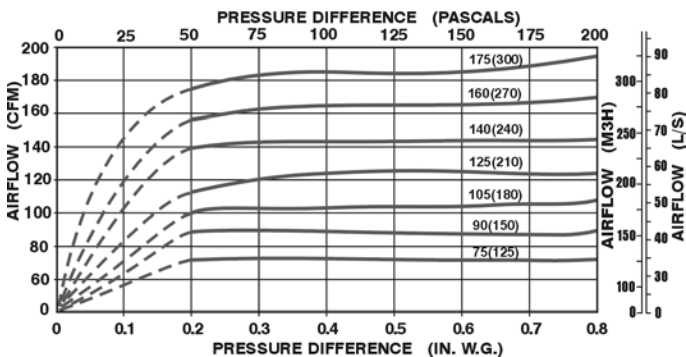

HOW THE CAR-II WORKS

Constant airflow is achieved by controlling the free area through the device. At minimum static pressure, the aero-wing is parallel to the air stream. As the static pressure increases, the aero-wing lifts, reducing the amount of free area through the regulator. At the same time, the higher static pressure increases the air velocity, resulting in **CONSTANT AIRFLOW**. This occurs regardless of pressure differences in the range of 0.2 to 0.8 in. w.g. (50 to 200 Pa). The air velocity in the duct is in the range of 60 to 700 ft/min. (0.3 to 3.5 m/s).

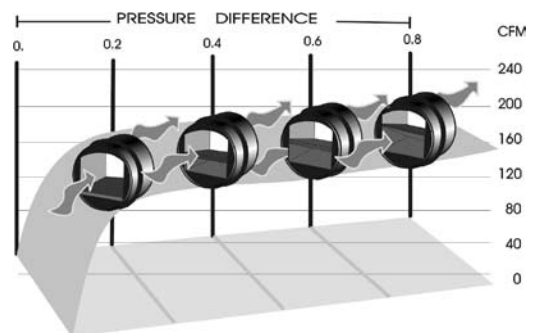

TYPICAL ZRT APPLICATIONS

ALDES INLINE FAN

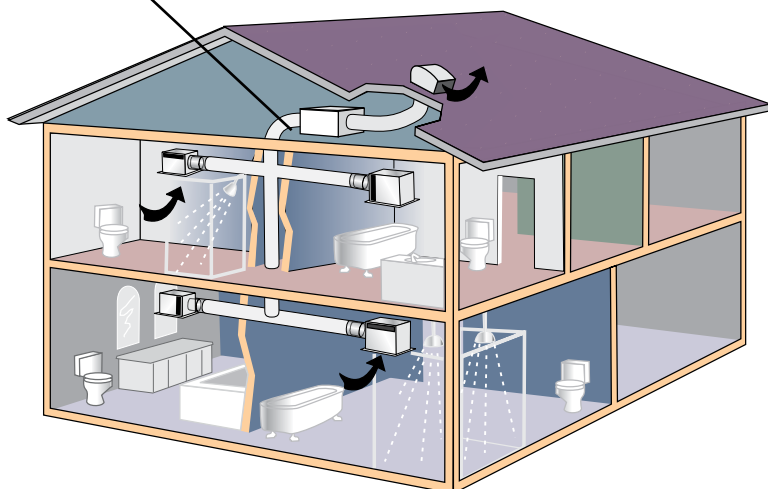

Example: ZRT-1 multi-zone central ON/OFF ventilation system

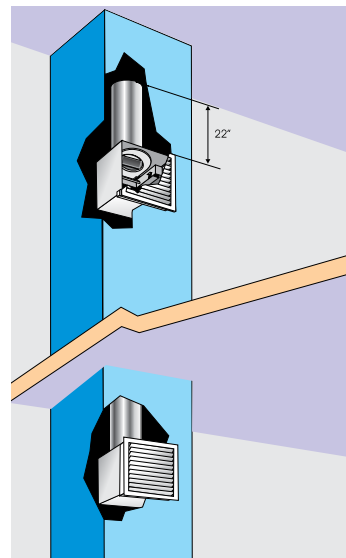

Example: ZRT-2 installed in a central ventilation duct riser

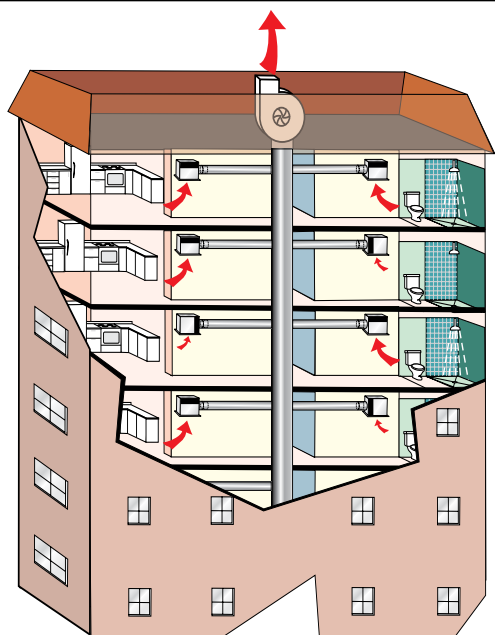

Example: ZRT-2 with optional maximum flow controls in high-rise central exhaust

ALDES MULTI-PORT FAN

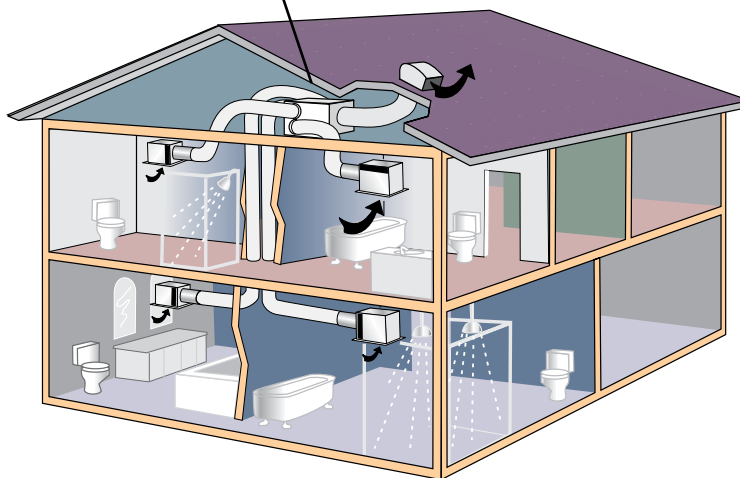

Example: ZRT-2 low continuous with no-limit maximum-boost ventilation control

WARRANTY

The entire unit is guaranteed for three (3) years, from date of shipment, against all manufacturing defects, provided the material has been installed and operated per manufacturer's instructions and under normal conditions. Warranty is limited to the repair or replacement of the material upon its return freight paid to our factory. This warranty is not transferable and is limited to the original end user.



4521 19th Street Court East, Suite 104
 Bradenton, FL 34203 - USA
 P: 941-351-3441 • F: 941.351.3442
 www.americanaldes.com • info@americanaldes.com

© 2012 American ALDES Ventilation Corporation
 Reproduction or distribution, in whole or in part, of this document, in any form or by any means, without the express written consent of the President of American ALDES Ventilation Corporation, is strictly prohibited. The information contained within this document is subject to change without prior written notice.



zrt_spec_1212