

Apalis – A New Architecture for Embedded Computing

A White Paper from Toradex



Management Summary

The complexity of today's embedded systems creates many challenges for engineers and project managers. The use of off-the-shelf computer on modules tremendously eases this situation. Computer-On-Modules (COMs) encapsulate the ever increasing complexity of modern hardware and software technologies, creating a single subsystem which can be easily integrated as a core component of an embedded product. This has the benefit of massively shortening the time to market while at the same time drastically reducing product development risk. The deployment of an off the shelf computer on module family decouples the customer from the underlying silicon vendors, greatly extending product lifecycle while reducing total cost of ownership.

Toradex presents the new Apalis Computer-On-Module family enabling customers to take full advantage of the latest advancement in technologies, making it possible to create leading edge products and user experiences for the embedded market.

The features and interfaces of Apalis™ are described, including specific value propositions like Direct Breakout™ and MXM SnapLock™. To demonstrate the advantages of the Apalis architecture the final section provides a comparison with other computer on module form factors.

Computer on Modules Capturing the Embedded Market

Today's development engineers of industrial products are facing many challenges, for which they have to come up with innovative solutions.

The microprocessor is at the heart of any modern embedded system. With an average innovation cycle of six to twelve months for Application Processors (AP) and System on Chips (SoCs), this is much shorter than the required five to ten year lifecycle for the embedded market, making the deployment of such technologies in embedded systems problematic if not impossible.

Consumer technology drives customer expectations; embedded systems that interact with people need to provide equivalent features and interfaces.

Devices must be intuitive; people no longer want to read user guides or manuals. 3D acceleration and multi touch support are mandatory for the Graphical User Interface (GUI). High speed connectivity using PCI-Express, SATA and Gigabit Ethernet coupled with multimedia interfaces such as HDMI are all necessary to ensure products live up to customer expectations.

Designing complex computing platforms to meet the demands of today's end customers takes many man years and requires highly specific expertise. To solve these challenges, development engineers have started to deploy off-the-shelf COMs. By purchasing the embedded computing platform as a complete, standardised subsystem, the development team can concentrate on the application, reducing development costs, risks and time to market.

Hardware and software maintenance of the COM is managed by the vendor, so the customer no longer has to worry about the lifecycle of individual components, massively reducing redesign risks and product maintenance overhead.

Another major advantage of choosing a computer module from a pin and functional compatible module family is the scalability of the end user product. By selecting the module that meets the requirements of specific application, customers can deploy product variants which are performance and price optimised for slightly different markets and segments.

For low to medium volume products, quite often a COM is the only cost effective solution, achievable due to the economy of scale leveraged by a large customer base deploying the same module. The cost benefit of using COMs in an application can often be realised well into volumes of several tens of thousands per year.

Colibri Computer on Module

In early 2005, Toradex released their first Colibri computer module. It is based on the Marvell™ PXA270, formerly Intel XScale™, and continues to be available until at least 2017.

Toradex continues to expand the Colibri family of modules which have been swiftly adopted by a diverse range of industries around the globe. Today the Colibri family contains ten pin and functional compatible module variants utilising Marvell PXA and NVIDIA® Tegra™ System-on-Chips (SoC) and ships to thousands of customers.



Colibri PXA270 Computer on Module

Toradex continues to innovate, develop and support our Colibri family. Features and improvements to the Windows™ CE OS for the Colibri PXA270 continue eight years after the initial product launch. Additional products will be added to the Colibri product family in 2013, demonstrating the commitment of Toradex to the longevity of the Colibri product family.

The Need for an New Standard for Embedded Systems

There has been dramatic growth in products using ARM™ processors, driven most recently by the expanding smartphone and tablet markets. ARM based solutions are appearing in areas previously reserved for high power x86 based solutions. At the same time, the likes of Intel® and AMD are trying to increase power efficiency in their x86 products in order to compete in areas previously dominated by ARM.

The gradual integration of interfaces such as PCI-Express, Gigabit Ethernet, SATA and HDMI into the latest SoCs and APs have driven the need for a new computer on module standard. These interfaces are enabling ARM devices to enter application areas such as digital signage and high-end multimedia, previously reserved for higher power, x86 based platforms.

Leveraging the decades of man years of expertise of Toradex in the embedded ARM market, Toradex has created the new computer on module standard, called Apalis™.

Apalis™: Expanding the Reach of ARM in Embedded Systems

The future proof Apalis computer on module family architecture has been developed based on research into different technologies and in close collaboration with our customers.

The main objectives for the Apalis architecture are as follows:

- **Longevity:** Apalis is architected with a very long-term lifecycle in mind, not being design around a specific SoC or AP. This decouples Apalis from individual SoC vendors and therefore provides extended lifecycle (10+ years) required for embedded products.
- **Extensibility:** A wide range of easily configurable interface options supports an almost unlimited variety of product applications. Provision to support as yet unknown interfaces ensures Apalis is ready for next generation connectivity and interface technologies.
- **Usability:** Complexity is encapsulated on the Apalis module, greatly reducing design complexity for customers. Apalis goes much further than any other COM standard, allowing all high speed signals to be routed to real world connector on a single PCB layer.
- **Compatibility:** Apalis provides full support for 3.3V voltage level on all GPIOs and industrial standard interfaces, a requirement for many embedded applications.
- **Simplicity:** Specific focus was put on simplifying power management. Reducing the number of voltage rails and power management signals required greatly helps to reduce design complexity, development time and total cost of the entire system.

Apalis Architecture

The diagram below shows the basic architecture of the Apalis module, listing the various interfaces by group. The broad variety of the embedded interfaces offered by Apalis, combined with the latest connectivity makes the module family the ideal solution for most of today's demanding embedded applications.

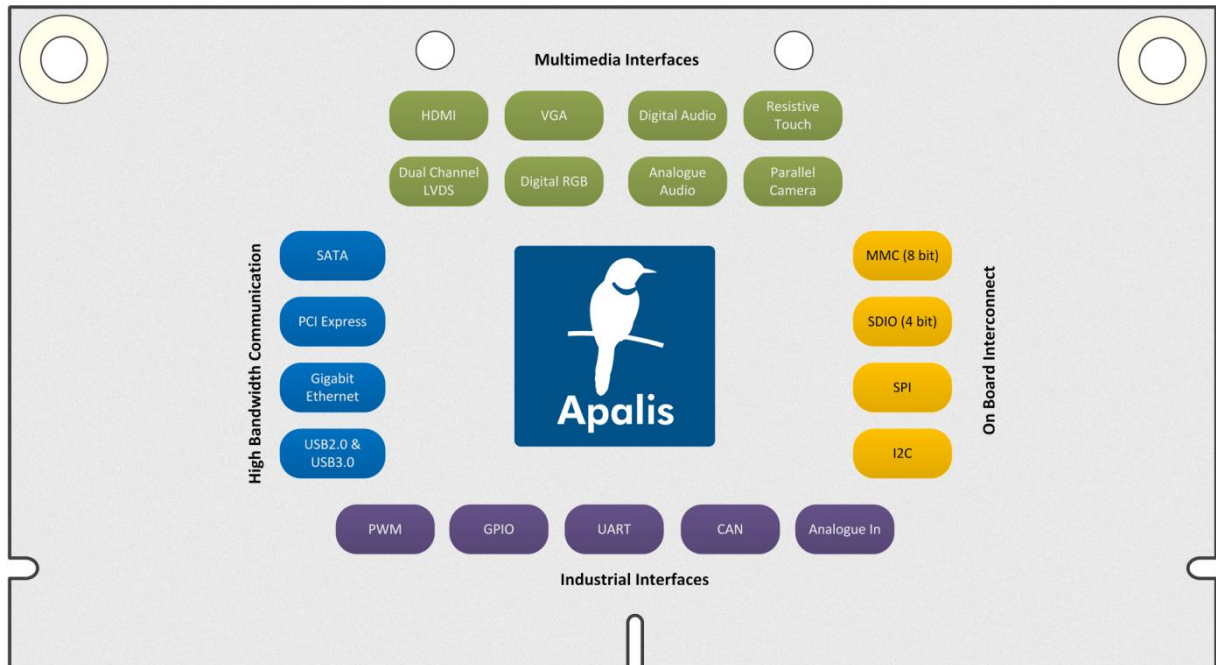

Apalis: Module Interfaces

Apalis allows customers to take advantage of continuous dynamic change in technology, while ensuring the statics of backward compatibility and product longevity. Although future trends are virtually impossible to predict, Apalis provides a stable solution without significant compromise, by splitting the supported interfaces into two classes: standard and type specific.

The standard interfaces of Apalis are defined with their common use across a wide variety of applications in mind. They provide long lasting, simple yet cost efficient connectivity. These interfaces are designed to be 100% compatible between different Apalis modules and allow for a price/performance optimised end product. A natural upgrade path to more powerful or cost optimized Apalis family members is thus available.

Type specific interfaces allow individual Apalis modules to utilise additional instances of standard interfaces (e.g. extra PCI-Express lanes or SATA ports) or technologies suited to specific applications, but with shorter lifetimes or constant evolution (e.g. MIPI CSI and DSI interfaces, largely driven by mobile markets). Type specific interfaces that are common between modules will generally share the same pins on the module connector, providing an acceptable level of compatibility.

Additional Value Proposition

Apalis features fully integrated, feature rich operating systems (Microsoft Windows Embedded Compact or Embedded Linux) and the extensive eco-system including a wealth of free hardware reference designs, software tools and libraries.

Additional features offered by Apalis tremendously cut down the development time of new products:

Direct Breakout™: Integrating Apalis into application specific carrier boards couldn't be easier. Direct Breakout™ technology allows the routing of signals directly from the module connector to outside world I/O ports without crossing traces or traversing layers. Especially when routing signals for high speed interfaces, such as USB, PCI-Express, SATA and HDMI, this greatly reduces the risk of signal integrity issues, enables the use of low-cost four layer PCBs, and significantly speeds up the placement and routing of designs.

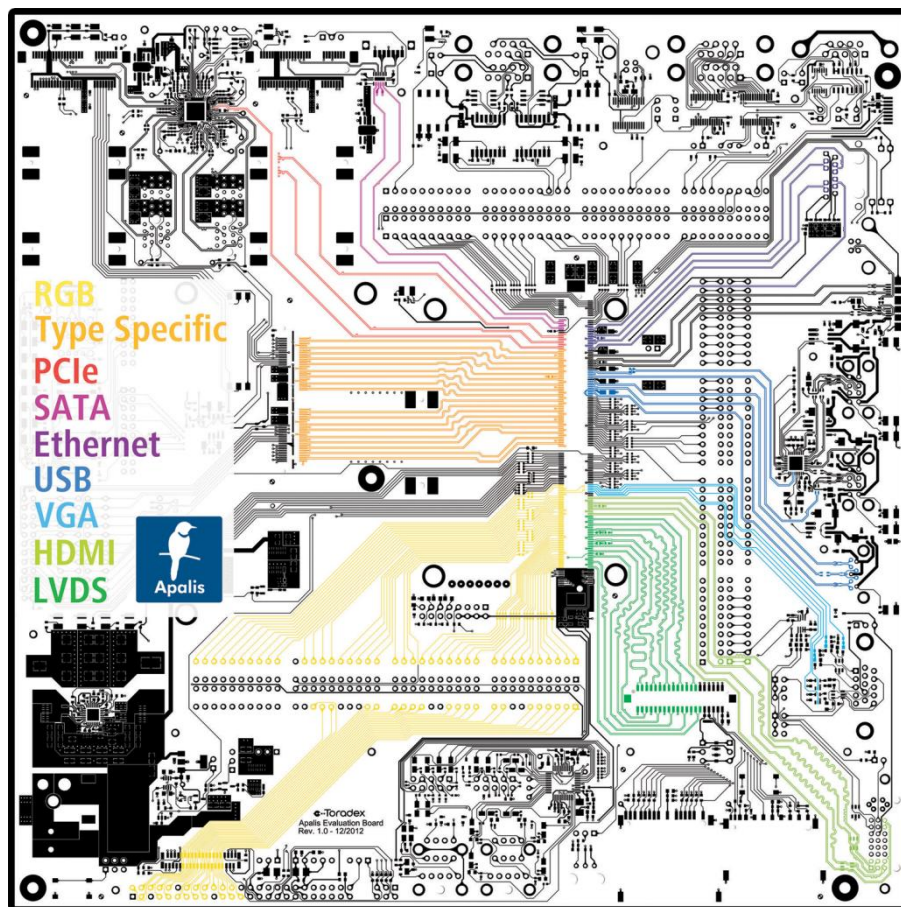

Direct Breakout™: PCIe, SATA and USB3 routed using a single layer on a 4 layer PCB (MXM3 COM connector to the centre right)

MXM SnapLock™: The Apalis module can be easily fixed to the carrier board by either screws or the unique MXM SnapLock™ mechanism. An edge retention connector mounted on the carrier board tightly fixes the module by means of two metal retaining clips and locating pips. For many applications and during development, this provides a simple retention mechanism. For applications exposed to high levels of vibration or harshness, the standard M3 mounting points provide a rock solid fixation alternative.

Cooling Solution: As performance advancement is accelerating faster than performance efficiency, we are seeing increasing power consumption in high performance ARM based SoCs. Passive cooling is still perfectly viable in most applications, although increased power consumption often requires additional cooling solutions such as heat spreaders. Apalis provides a robust, rigid mounting mechanism to support thermal solutions. A special pad on the bottom of the module doubles as a thermal relief and load absorbing mechanism, so an off-the-shelf conductive heat spreader can be attached to the top of the module. This cooling mechanism is easy to install and offers great flexibility.

Apalis T30

Apalis T30 is the first of many members of the Apalis product family, unleashing the computing performance of the NVIDIA® Tegra™ 3 Quad core Cortex A9 with the 12 core NVIDIA GeForce GPU.

The computer module incorporates Dynamic Voltage and Frequency Switching (DVFS) and Thermal Throttling, which enables the system to continuously adjust operating frequency and voltage in response to changes in workload and temperature in order to achieve the best performance with the lowest power consumption.



To demonstrate the advantages of the new Apalis Architecture the following table provides a basic feature comparison between three computer modules, all based on the same NVIDIA Tegra 3 Quad-core Cortex™ A9 SoC:

Feature	Apalis™ T30	ULP-COM™ /SMARC™ sAT30	Qseven™ QuadMo747-X/T30
Clip retention for easy insertion	MXM SnapLock™	-	-
Simplified placement and routing	Direct Breakout™	-	-
Mechanical Size	45 x 82mm	50 x 82mm	70 x 70mm
4 Wire Resistive Touch	1	-	-
ADC	4	-	-
Analogue Audio	1	-	-
CAN	2	-	1
CSI (Dual Lane)	2	2	1 (FFC connector)
DSI	1	-	1
Dual Channel LVDS	2x Single or 1x Dual	1 x Single	2x Single or 1x Dual
Gigabit Ethernet	1	1	1
GPIO	8*	12*	0*
3.3V support on all GPIO	Yes	No	N/A
HD Audio	1	1	1

Feature	Apalis™T30	ULP-COM™ /SMARC™ sAT30	Qseven™ QuadMo747-X/T30
HDMI (TDMS)	1	1	1
I2C	3	5	1
I2S	1	3	1
Parallel Camera	1	-	1 (FFC connector)
Parallel LCD	1 (24 bit)	1 (24 bit)	-
PCI Express (x1 Lanes)	5	2	4
PWM	4	2	2
SATA	1	1	1
SDIO	1	1	1
SDMMC	1 (8 bit mode)	1 (4 bit mode)	1 (4 bit mode)
S/PDIF	1	1	-
SPI	3	2	1
UART	4	4	2
USB	3	3	6
VGA	1	-	-

** Dedicated GPIO - additional GPIOs available on some unused interfaces*

The outstandingly rich feature set makes the Apalis T30 computer module an ideal fit for a very broad range of applications, including: Digital Signage, Medical Devices, Navigation, Industrial Automation, HMIs, Avionics, Entertainment System, POS, Data Acquisition, Thin Clients, Robotics and Gaming.

Online Resources on Apalis

More information on the Apalis module can be found at:

<http://www.toradex.com/products/apalis-arm-modules>

<http://developer.toradex.com/hardware-resources/arm-family/apalis-module-architecture>

Apalis modules can be purchased directly from the Toradex Webshop.

Toradex: Your One-Stop Provider for Embedded Technology

Toradex specialises in designing and delivering high performance ARM and x86 based computer modules for the embedded market. Our hardware and software offers unmatched configurability and hence enables you to quickly and cost-effectively transform concepts into successful products. The small form factor and ultra-low power consumption make our modules ideal for rugged and mobile applications.

Hardware and software components are designed and developed by our engineering team in Switzerland, with 100% commitment to ease-of-use, performance and quality. Direct support provided by these very same developers as well as a wealth of free reference designs, software tools and libraries massively speeds up your development time and - at the same time - reduces your development risk.

Toradex cares greatly about securing your supply chain, especially when your product enters volume production: products are sourced from multiple preferred manufacturing partners and delivered through the many local Toradex sales offices.

Furthermore Toradex frees up your resources: by deploying our computer modules you do not have to worry about hardware changes or software bugs in the operating system. Our standardised products benefit from free product maintenance for their entire lifecycle.

DISCLAIMER

Copyright © Toradex AG. All rights reserved. All data is for information purposes only and not guaranteed for legal purposes. Information has been carefully checked and is believed to be accurate; however, no responsibility is assumed for inaccuracies.

Brand and product names are trademarks or registered trademarks of their respective owners. Specifications are subject to change without notice.