

## INSTRUCTION MANUAL

Model: LED-77-48-3200(5600)  
 Lamps: 40 4 W LEDs driven at 2 W  
 Driver: Electronic, high frequency  
 Beam angle: 48 degrees  
 Voltage: 120, 230, 277 50-60 Hz  
 Manufacturer: PL Systems, Inc.  
 Address: 10529 Olympic Drive, # 102  
 Dallas, TX 75220  
 (214)-393-5998 (voice)  
 (214)-393-5999 (fax)  
 e-mail: info@kw2.com  
 Web page: primetimelighting.com

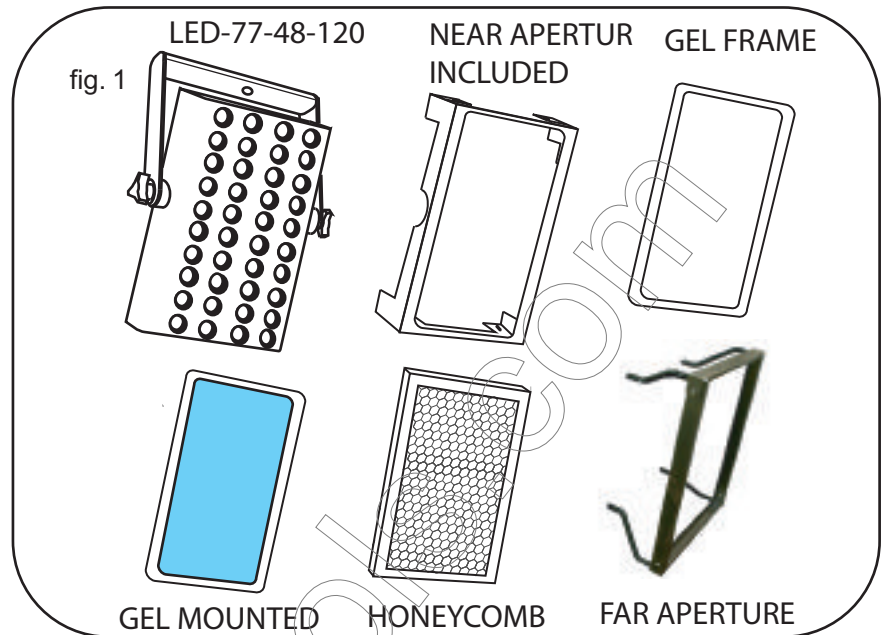

## GENERAL INFORMATION

Thank you for your selection of one of the most effective studio luminaires, the LED-77-48. This high performance luminaire should provide many years of low cost operation. The LED-77-48 is designed to maximize "punch" by focusing the light into a broad beam (+/- 24 dgr.) for directional fill and soft light, then the desired light pattern is achieved by use of gels or holographic filters to produce the desired spot size. Asymmetric beams are a reality with horizontal to vertical ratios of 6-1 being the norm. With appropriate filters the LED-77-48 will produce light patterns equal to soft lights and acts as broad wash for uniform illumination of green screens or CYC walls. Unwanted side glare is controlled with optional honeycombs. The luminaire provides a mounting slot for holding gel frames and/ or honeycombs. The LED-77-48 performs like a soft light for a fraction of the energy. The LED-77-48 draws a mere 85 Watts.

The LED-77-48 is offered in tungsten (3200 K) or daylight (5600 K).

The LED-77-48 is available in full power, voltage dimming, analog/on board dimming and DMX dimming. The LED-77-48 housing is made of aluminum and powder coated in non-reflective black. Accessories are made of steel and alloy aluminum. Standard luminaires are equipped with detachable 10' long power cords. Each 120 volt cord is equipped with Edison 3-prong connectors. Other voltage models are shipped without plug unless specified. Fused power receptacles are supplied for the 120 volt models. Adjacent fixtures may be powered with this connector so long as the load does not exceed 4 amps. (fig. 2) The switch controls the power to the one fixture. Power to the luminaire is indicated when the switch is lit. Ordinary grip devices allow stand mounting as well.

### CAUTION

Do not stare at the light source.

The LED-77-48 must be mounted in vertical orientation, as shown in fig1. This is to insure cooling of the LEDs through the ventilated case. Over heating will cause premature failure.

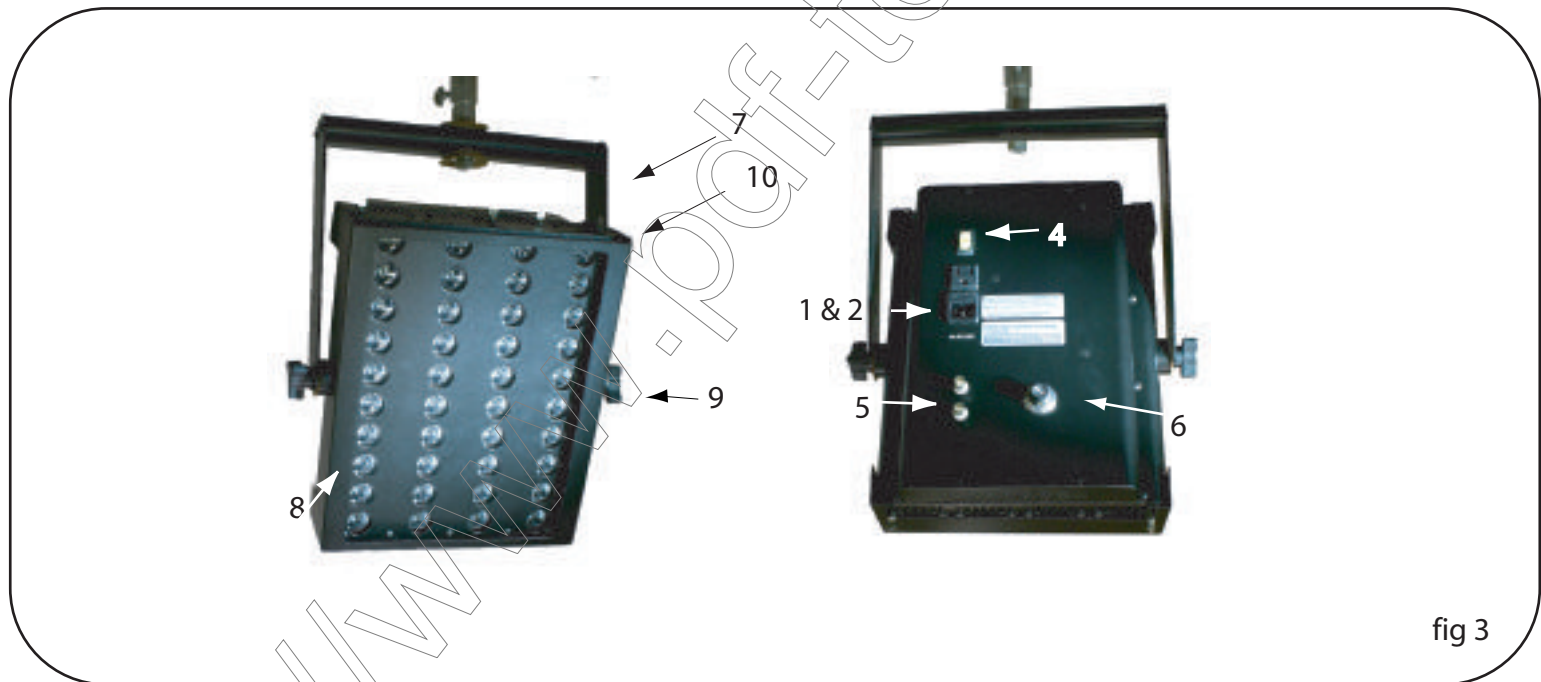
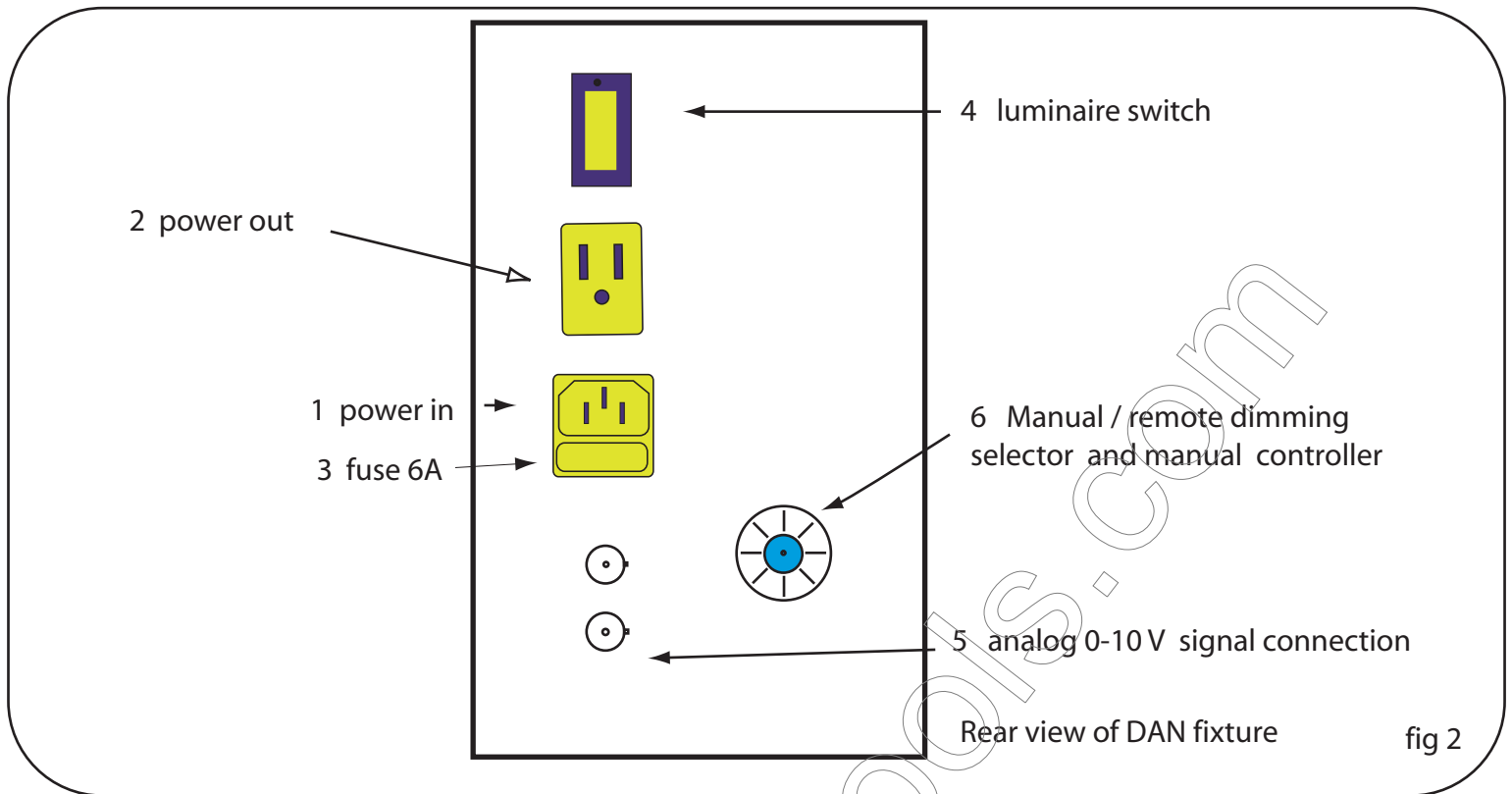

1. Power in 120 VAC removable power cable.
2. Power out to additional luminaires.
3. 6 amp fuse with spare.
4. Luminaire switch. Lighted switch indicates power to luminaire.
5. In and out remote 0-10 volt dimming signal ( BNC).
6. Local (manual) dimming control and local / remote switch.
7. Suspension adjustable yoke provides 70 dgr.altitude and 360 dgr.azimuth pointing.
8. Lens/reflector assembly which concentrates 4 watt high brightness LED's output.
9. Palm bolts allow tilt adjustment.
10. Adjustable gel-honeycomb slot.

table 1

LED77 shown with the standard "Near" gel frame and honeycomb holder. Mounted to it is the optional "Extender Kit" which will retain a honeycomb and a gel frame in the "Far" position. The extender kit is furnished complete with fasteners and an Allen wrench. It is factory assembled when ordered with fixtures.

Extender kit gel-honeycomb "far" aperture →

extender posts

"near" gel-honeycomb slot (incl.)

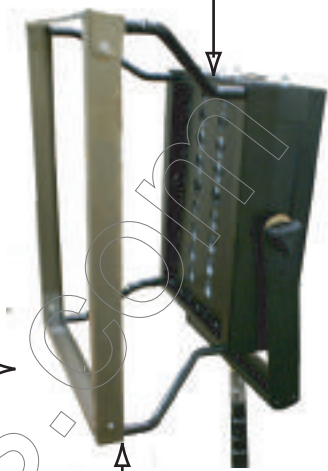

Stand or suspension mount

fig.4

## ACCESSORIES

The proper use of accessories will allow this luminaire to operate as a front light and as a directional soft light source for green screen/ CYC broad wash. (fig 5) The LED-77-48 provides a slot at the aperture which will hold a gel frame and a honeycomb. With it's 48 degree beam angle the LED-77-48 is suitable for front fill and chroma-key applications as well as multiple news anchor applications through the use of shaping gels. (fig. 7) Diffusing gels provide for uniform light when lighting walls or screens ( fig.8) Honeycombs and gels with laminated frames are available for the basic LED-77-48 and fit into the furnished aperture slot. Laminated gels as well as bare gel frames are available to allow use of non-standard gels.

The most effective use of the LED-77-48 for front light and soft fill light is with the extender honeycomb-gel accessory kit. (fig 4) The placement of gels in the "far" position provides for beam overlapping and gives the appearance of a single source of light while eliminating multiple shadow effects. Honeycombs eliminate side glare and make for easier tele-prompter perception. (fig.6) Laminated gel assemblies are available for the larger far aperture position as well as bare frames.

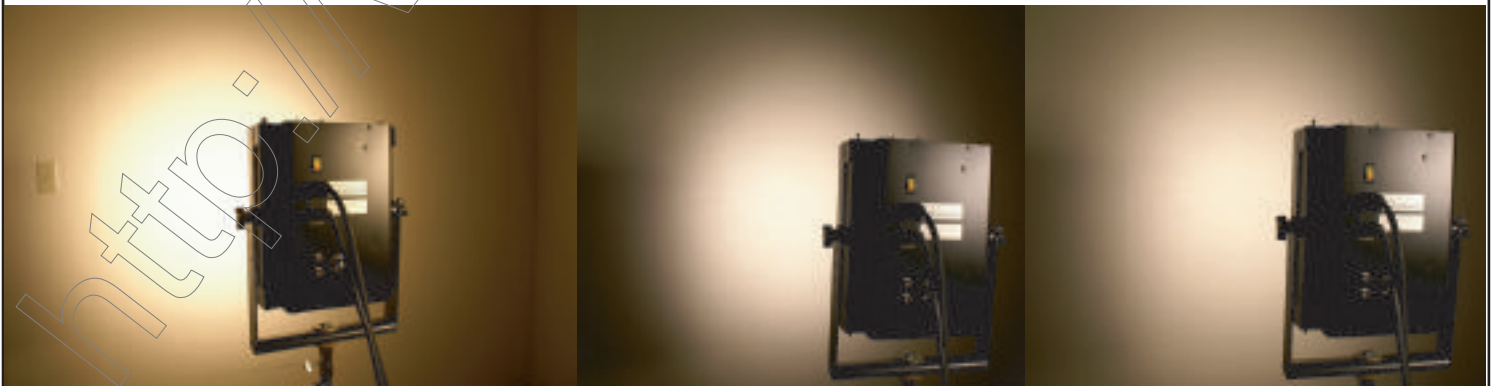

fig. 5

fig. 6

fig.7

## INSTALLATION:

Remove the luminaire from the shipping carton and inspect for any damage during shipping. If attenuators are ordered they may be installed in the aperture. If so, loosen the accessory slot cover retaining screws and slide the cover back to expose the slot.

It is advisable to bench test the fixtures before installation but a few precautions are in order. Make certain that the fixture cooling slots are not blocked when lit. Adjust the yoke so that the body of the fixture is tilted when on the table. This is important because the LEDs are cooled by convection of air through the body of the fixture. Do not block the vent slots. Do not place the fixture horizontal or mount with the yoke horizontal as overheating can occur which will shorten fixture life. When testing the fixture up close make certain not to look directly at the light sources from close proximity. It is good practice to install the filters to be used before turning on the luminaires. Install the power cord and plug into 120 volt service. Place the fixture so as not to block the cooling vents and turn on the switch. The fixture has a 2 second delay on starting. If the fixture has power the switch will be lit.

The LED-77-48-DAN version may be dimmed with 0-10 volt signal via the BNC connectors and one signal source may dim a number of fixtures by connecting fixtures together with BNC cables. DMX signals may be decoded to produce 8 or more individual channels per shoebox decoder equipped with BNC outlets. Each channel is considered a separate signal source. Local dimming control is provided by a dimmer controller with a local / remote selector switch.

Next, the hanging means should be mounted on the yoke with a 1/2" bolt supplied with the "C" clamp and or stem. With the stems and clamps attached, hang each assembly in the desired location on the 2" pipe grid or other qualified hanging system. Immediately add a safety cable as per fig. ( 8 )

The light sources cannot be changed in the field. Contact the factory for assistance.  
(214)-393-5998, fax 393-5999

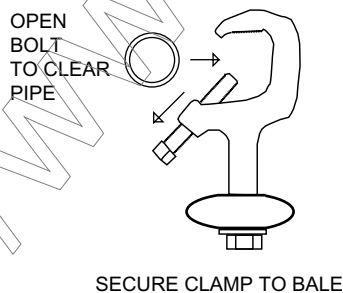

SECURE CLAMP TO BALE

TIGHTEN  
BOLT  
AGAINST  
PIPE

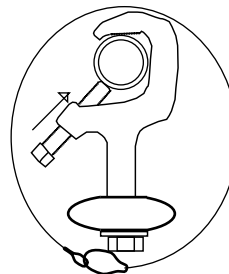

SECURE  
SAFETY  
CABLE

fig 8



**PrimeTime**

Lighting Systems®

Manufactured in the USA by:  
PL Systems, Inc.  
10529 Olympic Drive Suite 102  
Dallas, TX 75220 (214)-393-5998

## FUSE REPLACEMENT FOR FIXTURES WITH DETACHABLE POWER CORDS.

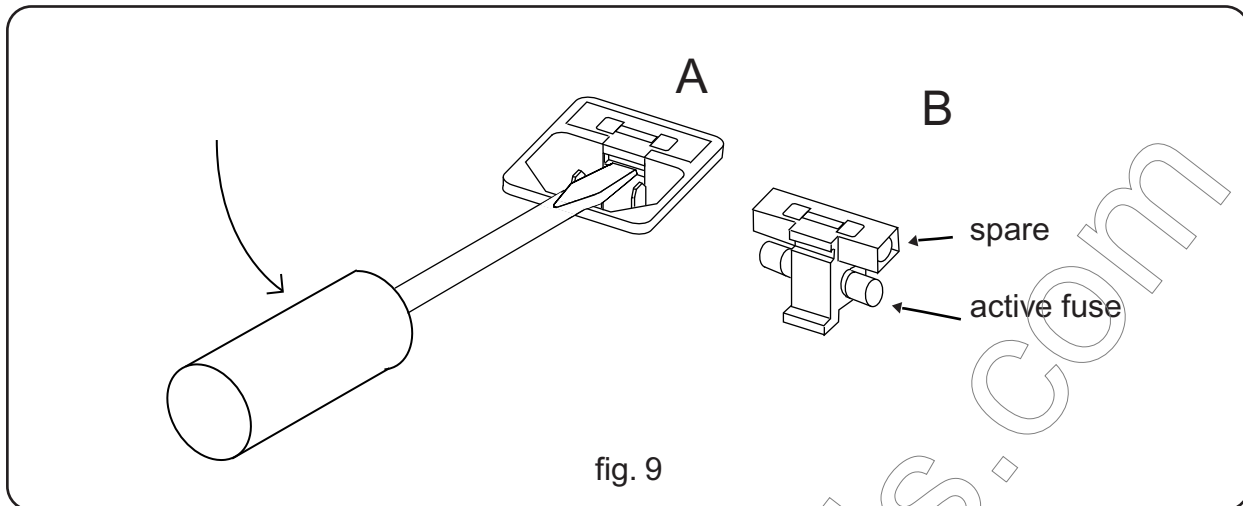

### DIRECTIONS

Fixtures equipped with detachable power cords contain fuses which are rated at 6 Amps @ 125 Vac. To replace fuse remove power cord exposing the receptacle as shown in fig. 10. Make certain there are no other cords attached to the fixture. Using a small flat screw driver, pry up the fuse holder shown in figure 9. Replace the fuse in the active slot and snap the fuse holder back into place. Use only fast acting type 217, 5 x 20 mm , 6 amp fuses.

### LINE POWER SCHEMATIC LED-31

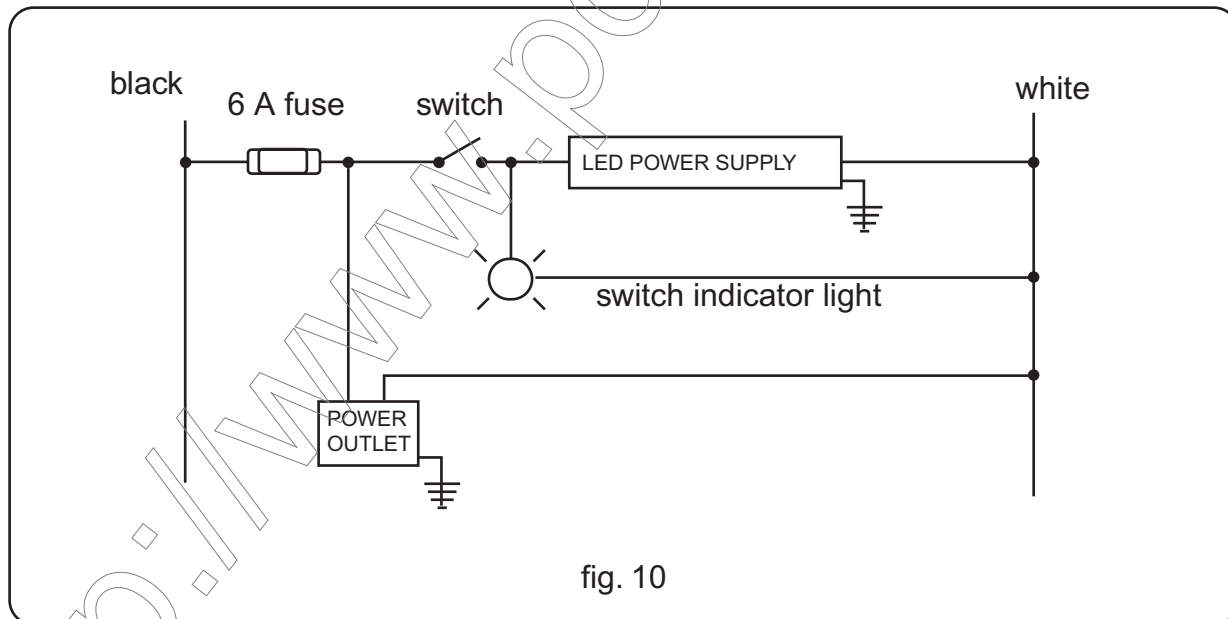

### CAUTION

Fused power out receptacle to be used for studio lights only. Maximum string wattage is 400. Fast acting fuse type 217, 5 x 20 mm , 6 Amps, 125 V.