

MA11M

Military Qualified Amplifier

Features

- ❖ Designed & Manufactured to Military Specifications
- ❖ Excellent Gain
G = 30dB
- ❖ Passes GPS, Galileo & GLONASS L1/L2
- ❖ Excellent Gain Flatness
Gain | L1 - L2 | <2 dB
- ❖ RoHS & WEEE Compliant

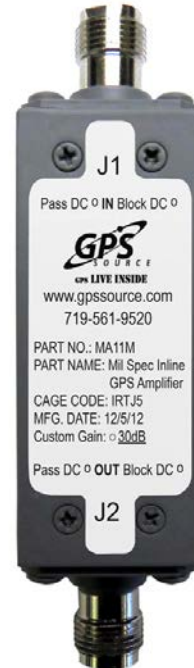

Description

The military qualified MA11M GPS Amplifier is designed with the thin link margins of satellite navigation systems in mind; and is a single stage gain block that covers the GPS, Galileo, and GLONASS frequencies. The device features 30dB of gain and excellent gain flatness of less than 1dB.

The MA11M splitter comes with many available options to meet your specific needs. Please call, fax, email (sales@gpssource.com), or visit our website (www.gpssource.com) for further information on product options and specifications. This device is designed for military applications and environments where high reliability is required.

This device has been designed and/or tested to the following MIL standards.

MIL-STD-810	MIL-E-5400
MIL-STD-1472	MIL-HDBK-454
MIL-STD-202	MIL-STD-1587
MIL-STD-883	MIL-STD-461
MIL-STD-704	MIL-STD-1275B

MA11M

Electrical Specifications, Operating Temperature -40 to 85⁰C

Parameter	Conditions	Min	Typ	Max	Units
Freq. Range	IN – OUT, IN/OUT-50Ω	1		1.7	GHz
Impedance	IN, OUT		50		Ω
Gain 1227 MHz 1575 MHz	IN – OUT, IN/OUT-50Ω	30	31	32	dB
		30	31	32	
Input SWR	OUT Port - 50Ω			2.0:1	-
Output SWR	IN Port - 50Ω			2.0:1	-
Noise Figure	Ant-Any Port, Unused Ports – 50 Ω, Gain = 10dB			3.2	dB
Gain Flatness	L1 - L2 , Ant - Any Port, Unused Ports - 50 Ω			2	dB
Group Delay Flatness	Td,max - Td,min , IN-OUT			1	nS
Reverse Isolation	OUT -IN	30			dB
Input IP ₃	IN – OUT, IN/OUT-50Ω Gain = 30dB, Tone spacing = 1 MHz	-22			dBm
Input P _{1dB}	IN – OUT, IN/OUT-50Ω Gain = 30dB	-12			dBm
DC IN	Non-Powered Configuration, DC Input on OUT port	5		7	VDC
Device Current	Current Consumption of device			65	mA
Ant/Thru Current	Pass DC Non-Powered Configuration, DC Input on OUT port			250	mA
Max RF Input	Max RF input without damage			30	dBm

General Specifications

Weight

The weight of MA11M is .25 pounds (113.4 grams).

MTBF

Mean Time Between Failure (MTBF) for GPS Source's MA11M Military Spec Mini Amplifier is 438,609 hours at 29°C and 386,361 hrs at 71°C.

Environmental Specifications

Temperature and Altitude

The MA11M complies with the temperature-altitude tests per MIL-STD-810C, Method 504, and Procedure 1 Equipment Category 5.

Explosive Atmosphere

The MA11M is designed for operation in the presence of explosive mixtures of air and jet fuel without causing explosion or fire at atmospheric pressures corresponding to altitudes from -1,800 feet to 50,000 feet. The MA11M does not produce surface temperatures or heat in excess of 400°F. The MA11M does not produce electrical discharges at an energy level sufficient to ignite the explosive mixture when the equipment is turned on or off or operated. The MA11M is designed to meet the requirements of MIL-STD-810C, Method 511.1, and Procedure II. Hermetically sealed equipment meeting the Requirements of MIL-STD-202, Method 112D, or MIL-STD-883, Method 1014.7 (as applicable), and not exceeding a Helium leakage rate of 1×10^{-7} cc/sec, are exempt from this requirement.

Salt Fog

The MA11M meets the requirements of Salt Fog conditions per Paragraph 3.2.24.9 of MIL-E-5400 and MIL-STD-810C Method 509.1. The MA11M can withstand a salt concentration of 5 percent at a temperature of 35° C for 48 hours without degradation.

Fungus

The MA11M meets the requirements of Fungus conditions per Paragraph 3.2.24.8 of MIL-E-5400 and MIL-STD-810C Method 509.1 i.e. fungus inert materials per requirement 4 of MIL-HDBK-454.

Humidity

The MA11M is capable of meeting the requirements of a ten-day humidity test conducted per MIL-STD-810C, Method 507.1; Procedure I. MA11M can withstand exposure to 95% relative humidity at a temperature of 30° C for 28 days.

Sand & Dust

The MA11M meet be capable of meeting the requirements of Sand and Dust conditions of method 510 of MIL-STD-810C, for a temperature of 145°F for duration of 22 hours.

Vibration

The MA11M is designed to meet the requirements of random vibration per conditions (MIL-STD-810C, Method 514.2, and Procedure 1A) to the levels defined below. Acceleration power spectral density (PSD) for the random vibration envelope is shown in Figure 1. Amplitudes for the functional levels and endurance level requirements are as shown in Table 1.

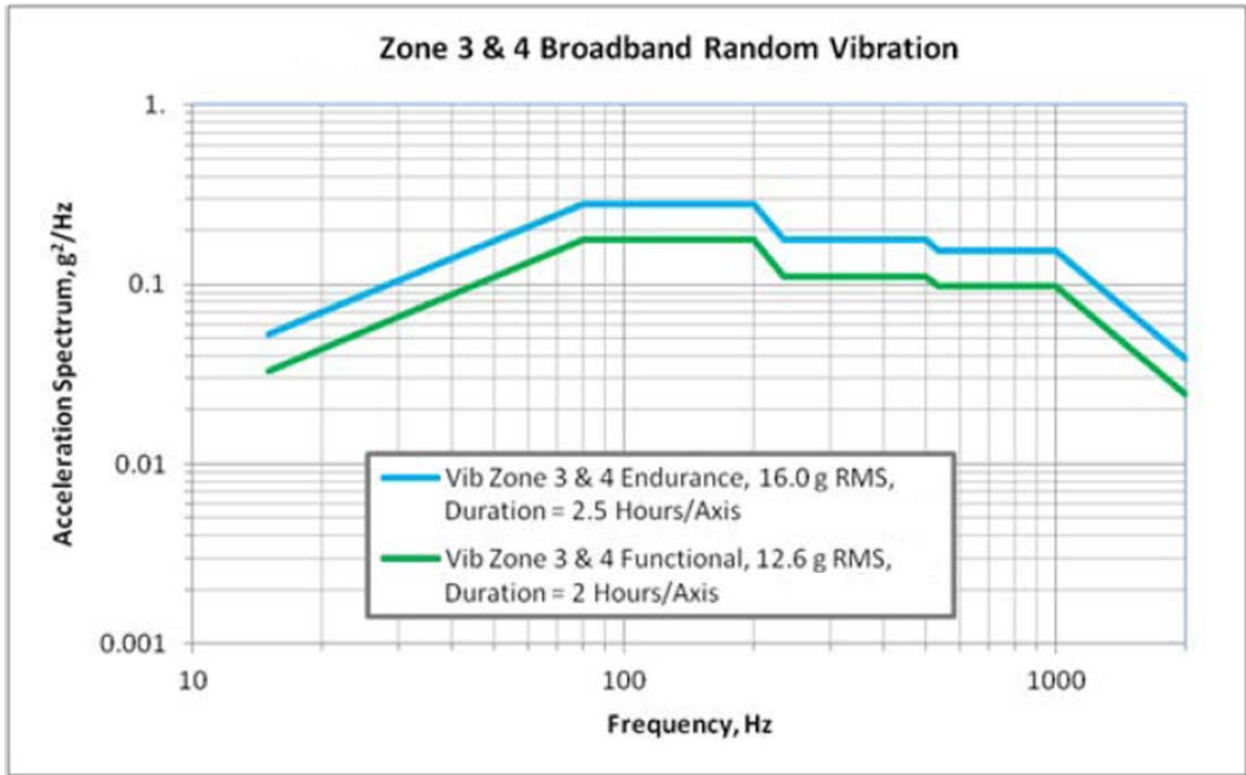

Figure 1

Vib Zone 3 & 4 Functional, 12.6 g RMS, Duration = 2 Hours/Axis	
Freq, Hz	g²/Hz
15	0.033
80	0.177
200	0.177
234	0.111
500	0.111
535	0.097
1000	0.097
2000	0.024

Table 1

Shock

The MA11M is designed to withstand the shock levels specified in the saw tooth shock pulse parameter specified in Figure 2.

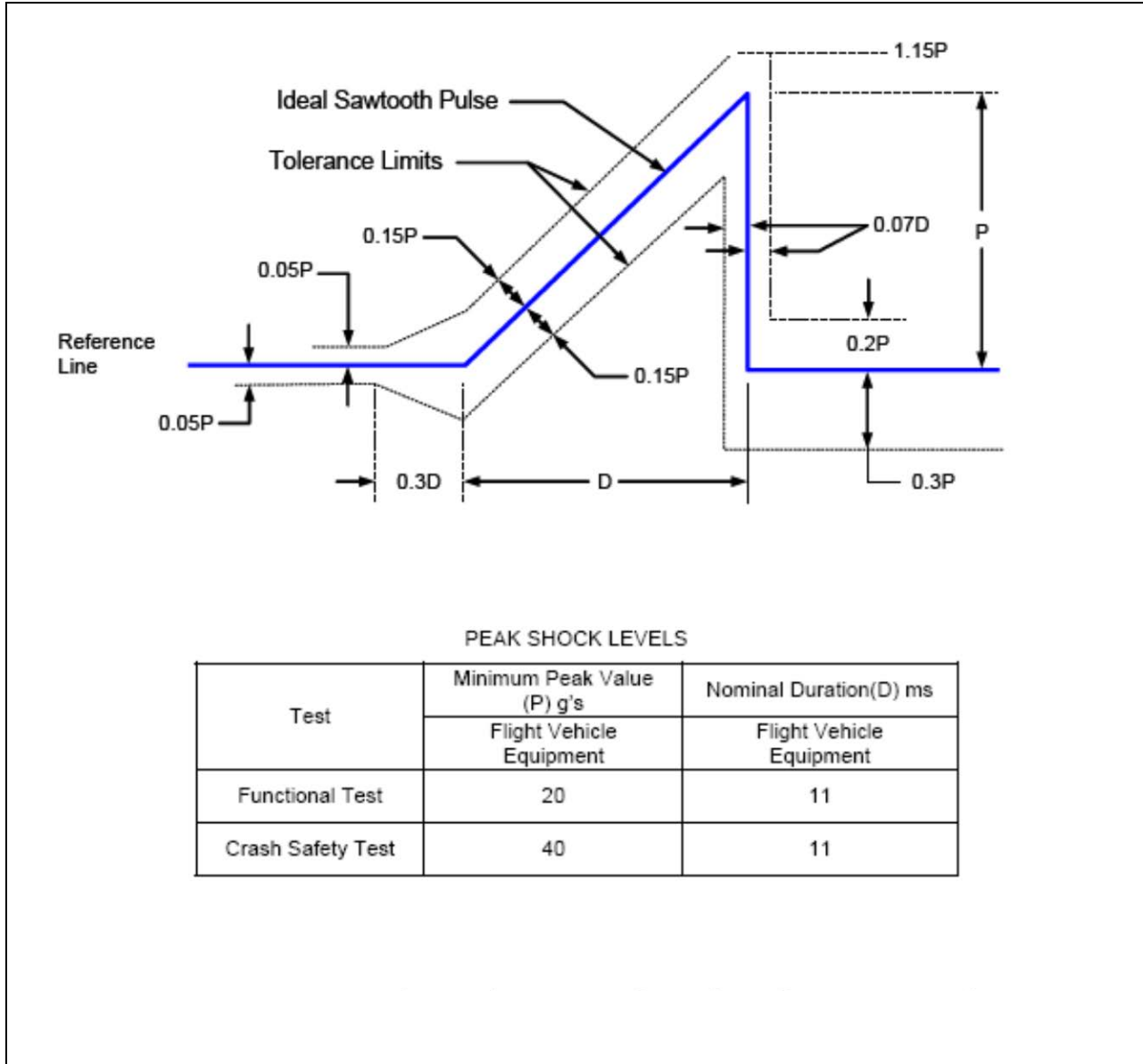

Figure 2

Decompression

The MA11M is designed to meet the performance standards per RTCA-DO-160E Para 4.6.2 cat D during and following a rapid and complete loss of normal cabin compartment pressurization (10,000 ft.) from an airplane flight altitude of 50,000 feet within 15 seconds. The MA11M will remain operating for 5 minutes at 50,000 feet before being returned to normal cabin pressure.

Overpressure

MA11M is capable of withstanding, for 10 minutes, while not operating, a 12.1 psi compartment pressure with no physical distortion or permanent set per RTCA-DO-160E PARA 4.6.3. The MA11M will operate satisfactorily upon return to normal pressure.

Temperature Shock

The MA11M will withstand without degradation (while not operating) Method 503.1, Procedure I of MIL-STD-810C.

Flammability

The MA11M is self-extinguishing or nonflammable and meets the Requirements of Paragraph 5.2.4 of MIL-STD-1587 and requirement 3 of MIL-HDBK-454.

Finish and Colors

All case surfaces of the MA11M are treated with chemical film per MIL-DTL-5441, TYPE II, and CLASS 3. The MA11M bottom contact surface is free of paint, or non-conductive finishes. The MA11M bottom contact surfaces are protected from corrosion by a conductive coating (MIL-DTL-5541). All other surfaces, except connector mating surfaces are primed per MIL-PRF-23377, TYPE 1 CLASS C and painted per MIL-PRF-85285, TYPE 1 COLOR NUMBER (26231), military gray (not lusterless variety) per FED-STD-595 (exceptions are bottom and connector surfaces are free of paint).

Human Factors

Human Engineering principles and criteria (including considerations for human capabilities and limitations) using MIL-STD-1472 in all phases of design, development, testing, and procedures development. The design is free of all sharp edges, according to MIL-STD-1472.

Electromagnetic Interference and Compatibility Test

Electromagnetic compatibility requires that the GPS MA11M perform its intended function and that its operation does not degrade the performance of other equipment or subsystems. The following table defines the test requirements and test procedures for conducting the required electromagnetic compatibility testing.

The MA11M is designed and tested to meet the following requirements of MIL-STD-461E:

Test	Description
CS101	Conducted Susceptibility, Power Leads, 30 Hz to 150 kHz
CS103	Conducted Susceptibility, Antenna Port, Intermodulation, 15 kHz to 10 GHz
CS105	Conducted Susceptibility, Antenna Port, Cross-Modulation, 30 Hz to 20 GHz
CS114	Conducted Susceptibility, Bulk Cable Injection, 10 kHz to 200 MHz
RE102	Radiated Emissions, Electric Field, 10 kHz to 18 GHz
RS103	Radiated Susceptibility, Electric Field, 2 MHz to 18 GHz
Indirect Lightning ⁽¹⁾	Damped Sinusoidal transients, RF Leads, 10 kHz to 100 MHz Damped Sinusoidal transients, Power Leads, 10 kHz to 100 MHz

Notes: 1. For additional detail regarding Indirect Lightning, contact GPS Source.

Performance Data:

MA11M

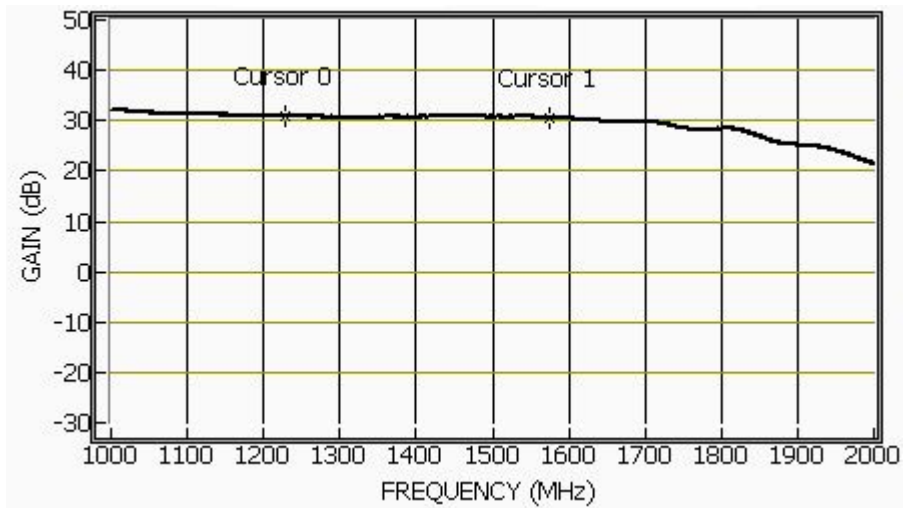

Figure 3. Gain vs. Frequency for an MA11M Amplifier

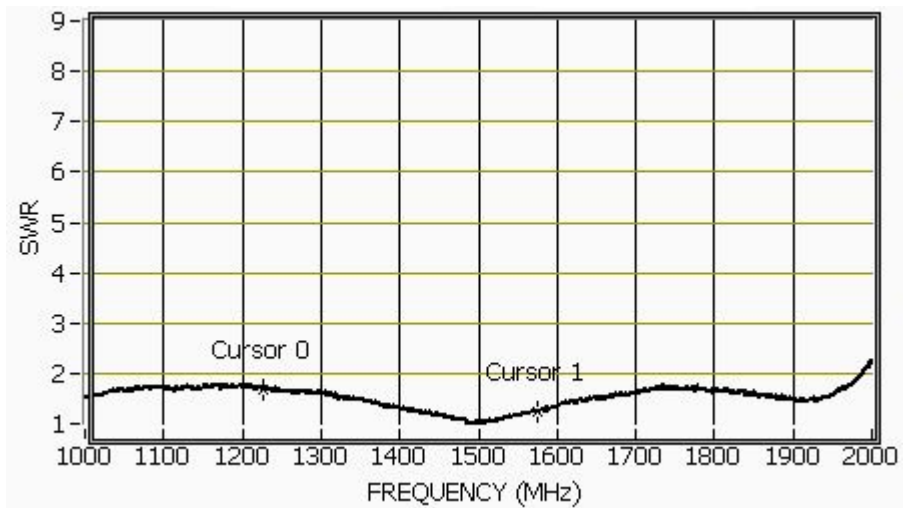

Figure 4. SWR vs. Frequency Plot for an MA11M Amplifier

Available Options:

RF Connector Options:		
Connector Options	Connector Type	Limitations
	N (Male & Female)	N/A
	SMA (Male & Female)	N/A
	TNC (Male & Female)	N/A
	SMB (Female)	N/A
	SMC (Female)	N/A
	BNC (Male & Female)	Performance Not Guaranteed
Housing Options:		
Housings	Housing Type	Limitations
	Mini	Powered Option Not Ava.
Port Options:		
Pass DC	IN Port Passes DC	
DC Blocked	IN Port Blocks DC	



“CAUTION” --- “ELECTROSTATIC SENSITIVE DEVICE REMOVE ELECTROSTATIC PROTECTION AT USE OR IN PROTECTED AREA REUSE PACKAGING MATERIALS FOR THE UNSERVICEABLE ITEM SEE DOD-HDBK-263 FOR PROTECTIVE HANDLING OR TESTING MEASURES FOR THIS ITEM “

MA11M

Part Number

MA11M - TF

Product:

Military Qualified
 Amplifier
 (J1 & J2 may be configured for Block or Pass DC)

Connector Option:

NM – N, Male
 NF – N, Female
 SM – SMA, Male
 SF – SMA, Female
 TF – TNC, Female
 TM – TNC, Male

For help in creating the part number to meet your exact needs, contact Sales@gpssource.com or visit our website at www.gpssource.com.

Mechanical

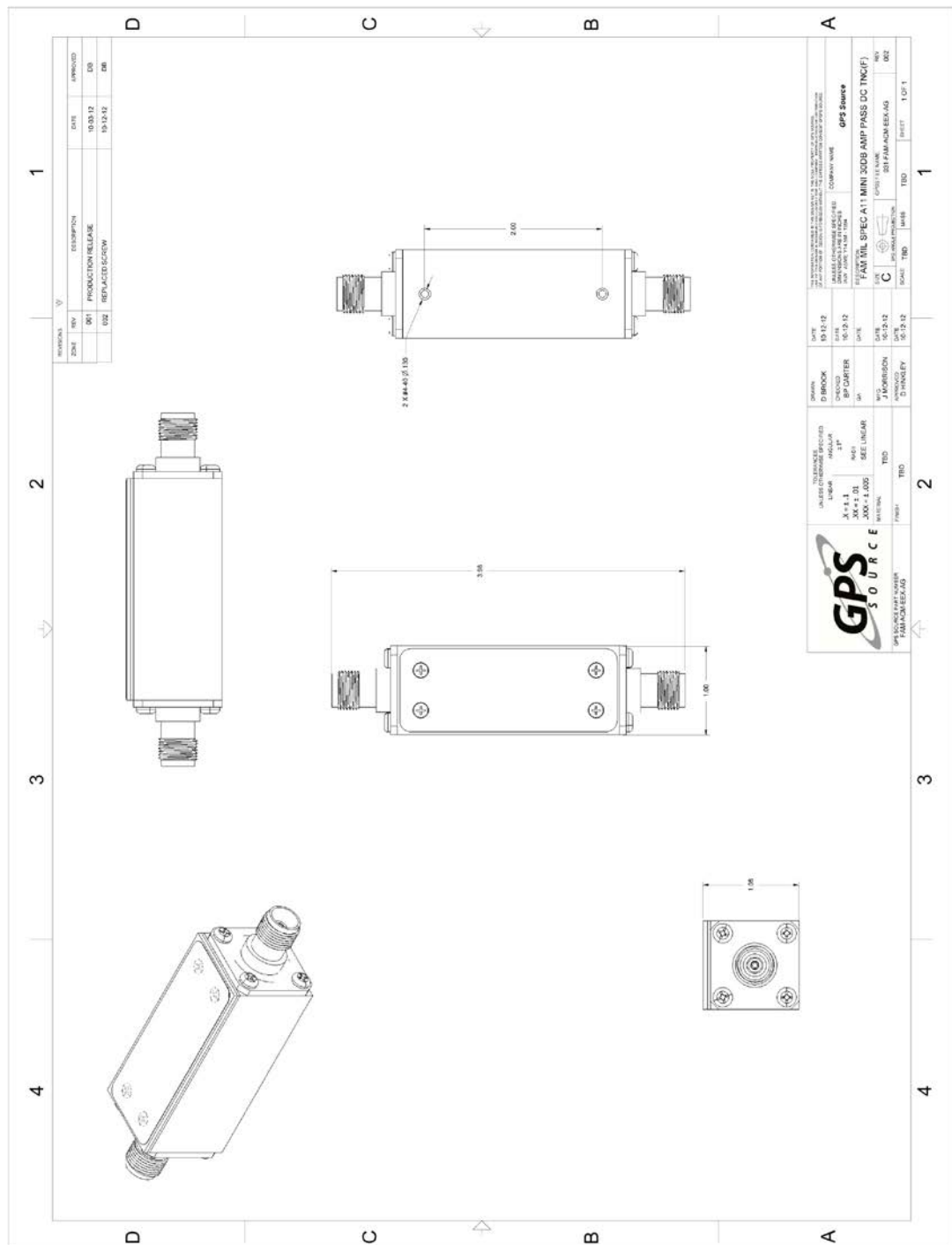

64 N. Mission Drive
 Pueblo, CO 81007
 Tel: 719.561.9520 Fax: 719.565.0890
 Email: techsales@gpssource.com

Author: Preetha Sayuj
 Department: R&D

AS9100C:2009 & ISO 9001:2008 Compliant Company

Description: MA11M Data Sheet
 Doc. No.: 1596-TS-MA11M-GPS-Amplifier-03
 Date: 03/08/2013
 www.gpssource.com