

MATERIAL IS: 16 GAUGE TYPE 316L SS
 PER ASTM A240 ASME SA-240
 FINISH: NONE

ALTERNATE MATERIAL: 16 GA. 1008-1010 CRS
 PER ASTM A1008/A109
 FINISH: ELECTRO ZINC PLATE PER ASTM-B633

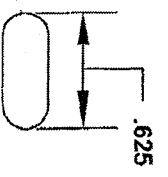

PARALLEL SLOT DETAIL

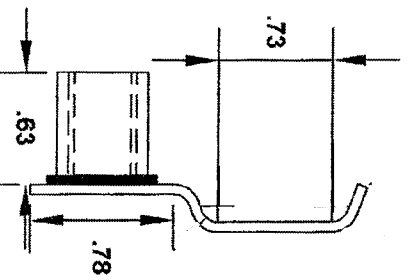

NOTE: STUDWELD FERRULE TO
 PLATE: 20 FT./LB MINIMUM YIELD

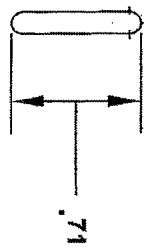

PERPENDICULAR SLOT DETAIL

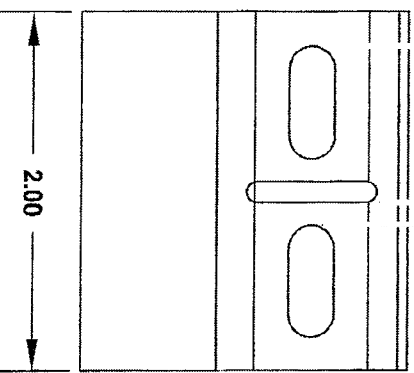
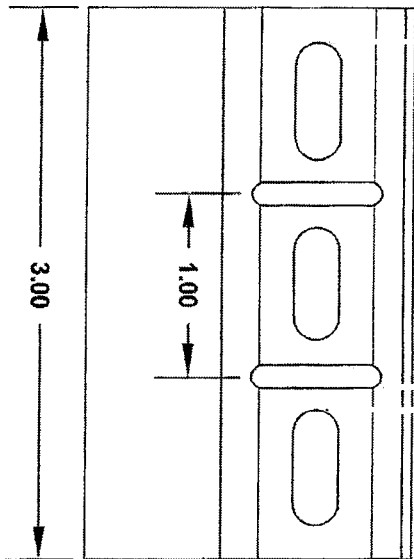

DIMENSIONS IN INCHES
 DO NOT SCALE DRAWING

TOLERANCES
 UNLESS OTHERWISE SPECIFIED

DECIMAL: XX +/- .09
 .XXX +/- .005
 .XXXX +/- .0005

ANGULAR: ALL 1°



Production Fastening Systems, L.L.C.

REVISION:

DESCRIPTION:

PFS-ESL PNEUMATIC TUBE HANGER
 2", 3" & 4" LENGTHS

DRAWING #:

ESL / SLP-2,3,4

SCALE: 1:1

DATE: 8-10-2012

SIZE:

A

THIRD ANGLE PROJECTION

