



ADRIAN STEEL®

Cargo Management Solutions for Commercial Vehicles

CARGO VAN EQUIPMENT

for RAM PROMASTER

& C/V TRADESMAN



PROMASTER PARTITIONS

ADRIAN STEEL PARTITIONS KEEP CARGO WHERE IT BELONGS, IN THE CARGO AREA!



Shown: S1M2C2PM Partition

S-M-C Series Partitions

Choose from solid or perforated top panels made from 18-gauge steel for strength and finished in a tough powder coat paint. Center M panels can be fixed or hinged with a key-locking door. Partitions are sold as panel kits and wing kits. Please see application chart to confirm the appropriate panel kit and wing kit for your vehicle. Partition panel kits and wing kits include assembly and installation fasteners for base van trim level. Higher trim levels may require modifying trim or partition.

Note: Extended wing kits reduce the amount of cargo space. Please confirm the interior layout of the van package to confirm that the extended wing kit has adequate room needed for installation.

S1 SOLID PANEL

Panels mount behind driver seat.

M1 SOLID PANEL

M2 PERFORATED TOP PANEL

Fixed center panels can be hinged as key-locking doors

C1 SOLID PANEL

C2 PERFORATED TOP PANEL

Panels mount behind passenger seat

PROMASTER PARTITION OPTIONS:

Fixed Center Panel

S1M1C1PM	All Solid Panels
S1M2C1PM	Center Panel Perforated Top Only
S1M2C2PM	Perforated Center and Curb Panels

Hinged Center Panel "Door"

S1M1HC1PM	All Solid Panels
S1M2HC1PM	Center Panel Perforated Top Only
S1M2HC2PM	Perforated Center and Curb Panels

Wing Kits Standard & High Roof

WKC1PM	Standard Position
WKC1PM3	Extended Position - adds 3" to the cab area (reduces cargo area)
WKC1PMR	Standard Position when Factory Partition was Removed
WKC1PMR3	Extended Position when Factory Partition was Removed - adds 3" to the cab area (reduces cargo area)

C/V TRADESMAN PARTITION

THE C/V WIRE PARTITION ALLOWS FOR MAXIMUM VISIBILITY



The P2RCV wire partition allows for maximum visibility out of the RAM C/V while its tubular frame gives it the strength to keep cargo out of the passenger cab.



PROMASTER PARTITION ACCESSORIES



PA11



TA1

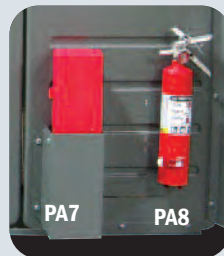

PA7

PA8



TH30



PDK1



PA9

TA1 Hook Bar maximizes vertical storage space. 2" x 12" bar mounts to partition or other vertical surfaces. Four welded hooks with 2" hanger opening.

PA11 Cab File Box mounts to partition or other vertical surface. Overall size: 14" W, 10-1/2" H, 3-1/2" D.

PA9 First Aid Box Tray secures first aid box to partition or other vertical surface. Overall size: 11" W, 4-1/2" H, 3-1/8" D

PA10 Practice Holder is a partition-mounted holder for forms, manuals or work related papers. Overall size: 12" W, 7" H, 5" D.

PA7 Triangle Reflector Kit comes with a metal pocket holder, I.C.C. approved.

PA8 1-A: 10-BC Fire Extinguisher is a rechargeable, 2-1/2 lb. dry chemical extinguisher. Stops Class A, B and C fires. Complete with charge gauge and mounting bracket

PA5-2 Partition Plexiglass Cover Panel is a clear panel that installs over the perforations of the ProMaster partition. Helps with climate control in the cab, and still allows for rear visibility.

TH30 or TH50 Refrigerant Tank Holder holds 30lb. or 50lb. tank to partition or other vertical surface.

PDK1 Door Kit converts M-Series fixed center panel into hinged door with keyed slam latch. Includes two 6" hinges, bulb seal and a slam latch. These features reduce vibration noise.



PA10

ADSERIES ADJUSTABLE SHELVING

EXCLUSIVELY FROM ADRIAN STEEL: A SHELVING PLATFORM THAT ALLOWS YOU TO PUT SHELVES WHERE YOU WANT THEM, NOT WHERE WE THINK YOU NEED THEM!

ADseries is the next generation of cargo management solutions, engineered to optimize your work van storage and accessibility. Featuring truly ADjustable shelves, an ADaptable rail system, heavy-duty shelves and an ADvanced stamped steel end panel designed to accommodate the diverse range of cargo you need to get the job done.



ADJUSTABLE SHELVES

Tools, equipment and cargo come in all shapes and sizes and until now, there hasn't been a shelving unit that is truly adjustable. The ADseries is the first of it's kind where, with only a screwdriver, you can simply remove the front shelf bolts and move the shelf where you need it. Shelves can be adjusted in one inch increments and provide the most flexible shelving solution available.



Model	Overall Size
HAD3259	32" x 59" x 14"
HAD4459	44" x 59" x 14"
HAD5059	50" x 59" x 14"

ADSERIES ADJUSTABLE SHELVING

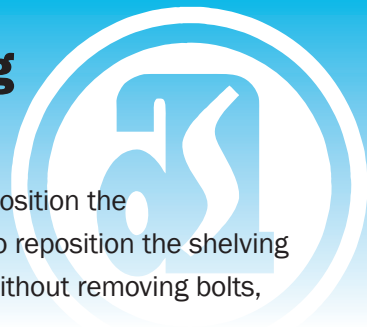

ADAPTABLE INTERIOR

Everyone likes to set their work van up their own way. The new ADseries shelving lets you position the shelving where you need it. Exclusive to the ADseries, the unique rail system enables you to reposition the shelving in the van, increasing the available space for trade specific equipment. All of this is done without removing bolts, plugging holes and redrilling the van!

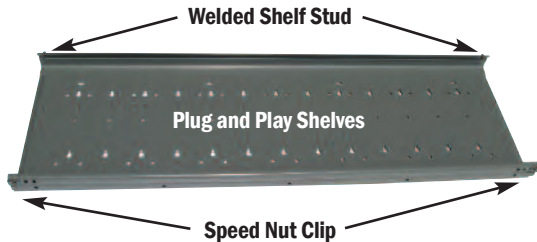

Truly Adjustable Shelves All you need is a phillips screwdriver! Simply remove two bolts from the speed nut clips that come with the shelf, tilt the shelf upwards, move the shelf to your desired location, insert the rear shelf studs, reattach the bolts and you're done!

Rear Shelf Studs unique design lock shelves in place!

ADD ACCESSORIES

Businesses change over time and your van interior should be able to change with your needs. Plug and Play shelves have pre-punched holes that allow adding storage solutions easily! ADseries dividers simply snap in place, drawer units simply bolt in and door kits can be added to lock your more valuable parts and equipment. Many Adrian Steel accessories can be added to the ADseries shelving with the rail adapter kits and end panel brackets.



ADSERIES SHELF UNITS AND RAIL KITS

Model	Size	Description
HAD3259	32"W x 59"H x 14"D	fits ProMaster, std. & high roof
HAD4459	44"W x 59"H x 14"D	fits ProMaster, std. & high roof
HAD5059	50"W x 59"H x 14"D	fits ProMaster, std. & high roof
RKPSWB	118" WB Rail Kit	ProMaster curb or streetside
RKPMWMB	136" WB Rail Kit	ProMaster curb or streetside
RKPMLWB	159" WB Rail Kit	ProMaster curb or streetside
RKPMXLWB	159"EXT WB Rail Kit	ProMaster curb or streetside

Note: Rails are not included with the shelf units. Rail kits must be ordered separately

Note: Shelves have the following weight rating:

- Shelves positioned with the shelf lips facing up have a rating of 100lbs per shelf evenly distributed.
- Shelves positioned with the shelf lips facing down have a rating of 200lbs per shelf evenly distributed.

ADSERIES ACCESSORIES

Model	Size/Description
DV14C1	Divider for ADseries/Single
DV14C8	Divider for ADseries/8 Pack
DK3008	8" High Door Kit/HAD3259
DK3010	10" High Door Kit/HAD3259
DK4208	8" High Door Kit/HAD4459
DK4210	10" High Door Kit/HAD4459
DK4808	8" High Door Kit/HAD5059
DK4810	10" High Door Kit/HAD5059
BRK14EPS	End Panel Bracket To Add on Accessories
RKA1	Rail Kit Adapter/See list at right
RKA3	Rail Kit Adapter3/See list at right
RKA4	Rail Kit Adapter4/See list at right
RKABRK1	Rail Kit Adapter/End Panel Bracket/See list
RKABRK2	Rail Kit Adapter/17A
RKAWTR	Rail Kit Adapter/Welded Tank Racks
RKA919	Rail Kit Adapter/#9, #19, #919 Drawer Units
35325-G	32" Long Shelf
35327-G	44" Long Shelf
35328-G	50" Long Shelf

RKA1 - Rail Adapter Kit1
Use with: CB2, CB3, CB4 (uses 2)

RKA3 - Rail Adapter Kit3
Use with: #1, #12, #2, #8, DC Units, 17A, CRH2, TA19, TA5

RKA4 - Rail Adapter Kit4
Use with: CL1446D/R, #40, KDRH2, KD Shelving Units, #33, #3, #33W, JD Shelving

BRK14EPS - ADseries end panel accessory attachment bracket. Use with: 17A, CB5, 43, TA19, TA20, WRH5, UH10/25/50, PA9, PA8, ACT3/4, PA11, AGSCH2, PA7, TH30, TH50, TA5

RKABRK1 - Used with TA19, TA20, TA5

CABINET MODULES

SPECIFIC JOBS DEMAND SPECIFIC STORAGE SOLUTIONS.

Cabinet and Drawer Modules provide secure storage for large and small tools and parts. The modular design allows you to get what you need now and the ability to add more when you need it. What ever the job demands, Adrian has the storage solutions to transport your gear safely and securely.



Tank Cabinets

- Provide vented storage for Propane, Mapp gas or CO2 tanks.
- Cabinets feature a full door gasket with two snap latches for positive door closure.
- Interior cabinet cradle and retaining straps (foam yokes for TA19) secure tanks and prevent movement.
- Floor vent and tubing are included for exhausting fumes.
- Propane cabinets store 20, 30 or 40 lb. tanks.
- Mapp Gas Cabinets store 6 1/2" diameter tanks.
- CO2 Tank Cabinets store 20 lb. cylinders.

Model	Description	Cabinet Size
TA18	Propane Cabinet	14-3/4"W x 36"H x 13"D
TA19	CO2 Tank Cabinet	13"W x 32"H x 12-1/2"D
TA20	Mapp Gas Cabinet	14"W x 26"H x 8"D

Vented gas storage solutions



Folding T handles don't stick out into aisles.

Shelf Cabinets

- Available in 12" and 18" front to rear lengths
- Can be used free standing or stacked with our lockable drawer units.
- Feature locking recessed tee-handles for secure storage and receive a durable gray powder coat finish.
- Cabinets feature an open side and can be combined for side-by-side use holding items up to 35" long.
- Optional end panel can be added to close off side when required.
- Include an adjustable shelf that can be removed
- Cabinets provide a solid surface to stack modular drawers, cabinets and bins.

Model	Description	Cabinet Size
1	Shelf Cabinet	18"W x 22"H x 18"L
12	Shelf Cabinet Open Side	18"W x 22"H x 12"L
1A	Optional Shelf	No. 1
12A	Optional End Panel	No.12



Cabinet Lockers

- Full-door Lockers feature a 46" high storage space with 3 removable shelves.
- Short-door Lockers feature a 33" high storage area and with 2 removable shelves.
- Locker doors are reversible for flexibility and feature locked recessed T-handles for security.
- Cabinet Lockers taper from 14" to 12" from front to back in depth at top and bottom to maximize aisle space.

Model	Description	Cabinet Size
CL1446R	Cabinet Locker Full Door	18"W x 46"H x 14"D
CL1446D	Cabinet Locker Short Door	18"W x 46"H x 14"D

DRAWER MODULES



2-1/2" deep drawers come with ABS divided and removable trays perfect for small parts.

NEW gLIDES!

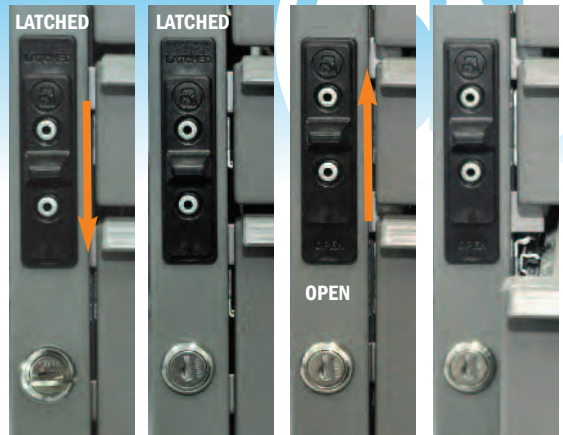

Latched & Locked **Latched & Unlocked** **Drawers Unlatched** **Drawers Open**

Drawer Units - Lock 'n Latch System

- Our exclusive Lock 'n Latch system provides a choice of drawers open, drawers retained or drawers locked position.
- Drawers are made of an engineered composite material for durability with ALL NEW heavy-duty drawer glides for support and smoother drawer operation.
- The new drawer glides significantly increase the ease of use when opening and closing the drawer units. They all but eliminate the rattle noise of the drawers when the driving the vehicle.
- Drawers and glides can be repositioned within cabinet for increased flexibility.
- Divide 5" deep drawers into compartments using optional metal "egg crate" dividers.

Model	Description	Drawer Size (Qty.)
19	2 Drawer Medium	16"W x 5"D x 11-1/2"L (2)
919	3 Drawer Combo	16"W x 2-1/2"D x 11-1/2"L (2) 16"W x 5"D x 11-1/2"L (1)
9	4 Drawer Shallow	16"W x 2-1/2"D x 11-1/2"L (4)
27	Divider Kit	Nos. 19 or 919 Drawer (1) 13-3/4"W x 2-3/4"H x 11-3/4"L

Steel outer cabinet measures 18"W x 12"H x 12"L.

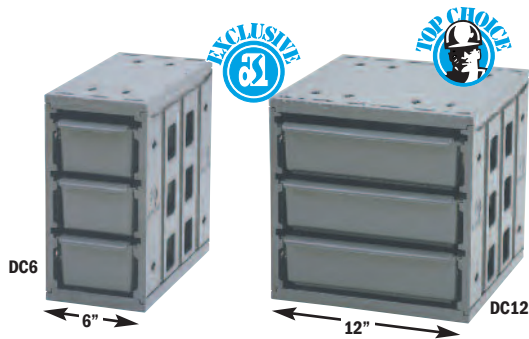

Drawer Components

- Organize small parts with our flexible and rugged composite Drawer Components.
- Drawer retention stops prevent drawers from opening while the vehicle is in transit.
- Made of a hi-impact polymer for a quiet operation.
- Each drawer comes with 2 dividers and 7 divider slots.
- Interlocking feature allows up to 2 units stacked vertically or multiple units horizontally.
- Choose from Adrian Steel's pre-configured drawer systems or create your own drawer system from the base models.

Model	Description	Overall Size
DC6	Base 3 drawer narrow model	6"W x 12"H x 12"D
DC12	Base 3 drawer wide model	12"W x 12"H x 12"D
DS06212V	Drawer System (2) DC12's	12"W x 24"H x 12"D
DS36012H	Drawer System (3) DC6's	18"W x 12"H x 12"D
DS46012	Drawer System (4) DC6's	12"W x 24"H x 12"D

5lb. weight capacity per drawer.

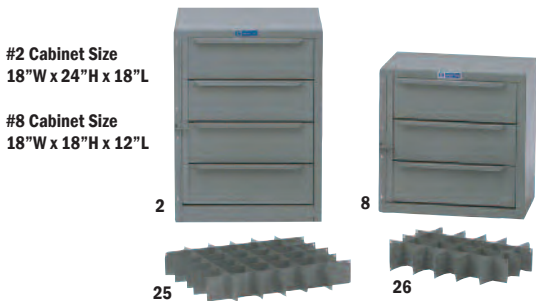

Drawer Units - Locking Hinge and Hasp

- Drawers are welded and have reinforced drawer slides for strength.
- Can be locked with a padlock (not included) for security.
- Divide drawers with optional metal "egg crate" dividers.

Model	Description	Drawer Size (Qty.)
8	3 Drawer Medium	16"W x 5"D x 11-1/2"L (3)
2	4 Drawer Medium	16"W x 5"D x 17-1/2"(4)
25	Divider Kit	No. 2 Drawer (1) 15-1/2"W x 2-3/4"H x 17-1/2"L
26	Divider Kit	No. 8 Drawer (1) 15-1/2"W x 2-3/4"H 11-1/2"L

Tote Trays and Cases

- Take small parts and tools right to the job site with removable tote trays and cases.
- Totes measure 18-1/2"W x 3"D x 12-1/2"L and are available in both steel tray and poly case designs.
- Steel tote trays feature fold-down carry handles and four large storage compartments with adjustable dividers.
- Poly tote cases offer a see-through lid with latches to prevent spilling,, four large compartments and twelve adjustable dividers.
- Trays and cases store in a 19-3/4"W x 20-1/8"H x 13-3/8"L modular rack that can be stacked or floor mounted.



Portable trays

Model	Description	Tote Style (Qty.)
SPT-4	Combo Totes and Rack	Steel Trays (2) Poly Cases (2)
SPT-4P	Poly Totes and Rack	Poly Cases (4)
SPT-4S	Steel Totes and Rack	Steel Trays (4)
SPT-S	Additional Steel Tray	
SPT-P	Additional Poly Tote	

CARGO VAN ACCESSORIES

ADRIAN'S BLUE BIN SYSTEM IS PERFECT FOR VISUAL INVENTORY MANAGEMENT.



- 6" and 12" bins maximize the ADseries shelf space.
- The bins can nest on top of each other when at the job site or in the warehouse getting filled to go.
- Add a label to the front so you can find parts quickly
- Each bin can accommodate one optional divider.

Order our predefined bin systems or create your own configuration of bins. Please note that the bins and the rail are a system. To obtain all the features listed above, both must be ordered.

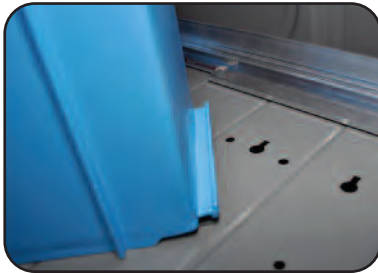

The innovative rail system locks the bins in place on the shelf.

Blue Bin Systems

Model	Description
SBIN060614	6" Blue Bin
SBIN120614	12" Blue Bin
SBINDIV	Divider
BR36212	Bin System: 3-6" & 2-12" bins w/rail
BR76012	Bin System: 7-6" bins with rail
SRAILAD26	26" Retention rail
SRAILAD32	32" Retention rail
SRAILAD44	44" Retention rail
SRAILAD50	50" Retention rail

ALUMINUM FLOOR DRAWERS ARE LOADED WITH FEATURES!

- Adrian Steel exclusive Anti-Slam latch keeps drawer from closing without positive latch activation. The only aluminum drawer in the industry with this feature!
- An automotive grade lock keeps expensive cargo secure and the adjustable divider helps keep contents segmented.
- The integral latch keeps the drawer open when you are on an incline and closed when you are done!
- Heavy duty grab handles and ball bearing slides allow the drawer to open and close with ease.
- Can be stacked to utilize large cubic storage areas.
- 24" deep units have a weight capacity of 350 lbs. and the 36" deep have a 325 lb. weight capacity.



AFD181236
weight 52lbs.



AFD241224
weight 46lbs.

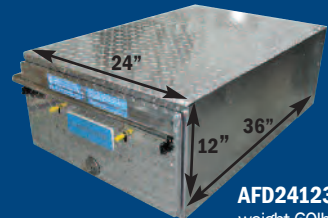

AFD241236
weight 60lbs.



- 1: CB5 Five Slot Literature Holder** Mount on partition or other vertical surface. 2-1/2" deep pockets. Overall size: 12"W, 24"H, 2-1/2"D.
- 2: CB7 Seven Slot Literature Holder** Mount on partition or other vertical surface. 6-3/4" deep pockets. Overall size: 14-3/4"W, 28-7/8"H, 7"D.
- 3: 17A Six Shelf Catalog File** Designed for catalogs but also serves to store a variety of materials between the 3" shelf spacings. Overall size: 11"W, 24"H, 12"D.
- 4: 43 Three Shelf Catalog File** Fits in narrow spaces. It has three tilted shelves. Perfect for binders and catalogs. Overall size: 6" W, 34" H, 12" D.

- 5: BH4 Four Slot Binder Holder** Designed to mount on partition or almost any vertical surface. Excellent for binders. Each pocket is 2 1/2" deep. Overall size: 12-3/4" W, 19-1/2" H, 2-1/2" D.
- 6: CB2 Two Book File** Mounts on the floor between front seats and partition. Holds folders 12"H x 10-1/2"D. Overall size: 6"W, 14"H, 12"D.
- 7: CB3 Three Book File** Mounts on cabinet tops or on the floor. Multiple units can be flush-mounted. Holds folders 12"H x 10-1/2"D. Overall size: 10-3/4"W, 14"H, 12"D.
- 8: CB4 Utility Storage Box** Stores a variety of printed material. Also suitable for keeping tools, safety glasses, gloves and other items. Hinged lid. Overall size: 12"W, 12"H, 14"D.

CARGO VAN ACCESSORIES

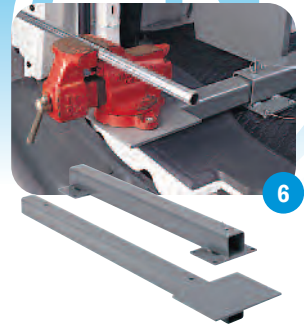

1: DST21 Door Storage Tray offers convenient access to parts and tools.

Overall size: 20" W, 4" D, 8" H

2: Aerosol Can Tray secure cans for easy access.

ACT3 - 3 Can Tray Overall size: 11-3/4" W, 4" D, 6-3/4" H

ACT4 - 4 Can Tray Overall size: 15-7/16" W, 4" D, 6-3/4" H

3: 14 Step Stool has a wide base and is 12" high. Stool can be used as a workbench or auxiliary step. Top measures 10" x 20" One size.

4: TA2 Hard Hat Holder secures hat to partition or shelving.

5: TA3 Saw Holder holds two hand saws.

6: VMA36 Vise Mount Assembly is floor mounted and telescopes out beyond side or rear cargo doors when fully opened. Measures 36" closed and 60" open.

7: Touch-Up Paint in spray cans match Steel-Cote™ finish. Three colors:

STP12G - Gray **STP12W** - White **STP12B** - Black

8: Door Tray comes with two dividers and has optional lid for containment.

DT21 - Door Tray Overall size: 18" W, 4" D, 4" H

DTL21 - Door Tray Lid for DT21 only

DTWL21 - Door Tray with Lid Overall size: 20" W, 4" D, 4" H

9: Parts Tray features a 2" deep shelf lip. Can be mounted to cabinet and drawer modules for added top storage.

4A - Parts Tray Overall size: 36" W, 12" D, 2" H

4B - Parts Tray Overall size: 18" W, 12" D, 2" H



Storage for small parts

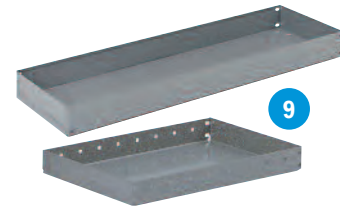

Wire Window Screens add security to cargo area windows.

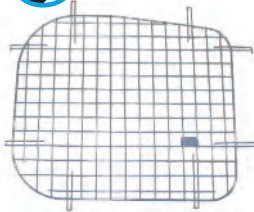

60-PM-MLXW ProMaster curbside sliding door and rear door Window Screen Kit.

60-129 ProMaster Rear Door Screen (1)

60-131 ProMaster LWB Sliding Door Screen (1)



Hooks

Model	Description
UH10	1" hook
UH25	2-1/2" hook
UH50	5" hook
TA1	4 Hook Bar



Cargo Straps

Model	Description
CS9	9" strap
CS15	15" strap
CS21	21" strap
CS31	31" strap

REEL HOLDERS



1: CRH2 Cable Reel Holder features a durable frame, two steel shafts that holds up to a 15-1/2" diameter reel by 14" wide. Overall size: 19-1/8" W, 16" D, 44-7/8" H

2: KDRH2 Cable Reel Holder holds large spools up to 16" wide and 18" in diameter. Spools nest on conveyor rollers. Includes tie-down chains with neoprene covers. Overall size: 18" W, 46" H, 18" D

3: WRH5 Wire Reel Holder Five removable bars hold wire spools up to 6" in diameter. Reel Holder mounts to shelf ends or any vertical surface. Overall size: 12" W, 25" H, 4" D

4: End Panel Reel Holder Bar mounts between ADseries shelf end panels for easy access to spools of cable and wire.

KDRH1426 - fits 26" shelf
KDRH1444 - fits 44" shelf

KDRH1432 - fits 32" shelf
KDRH1450 - fits 50" shelf

PROMASTER ALUMINUM UTILITY RACK

MAXIMIZE YOUR CARGO CAPACITY WITH AN ALUMINUM UTILITY RACK.



UTILITY RACK - PROMASTER STANDARD ROOF

- This all aluminum rack is designed to reduce corrosion by eliminating much of the welding.
- The uprights are fully plastisoled to protect against wear and reduce ladder fatigue.
- Uprights feature many attachment points for securing cargo straps.
- Weather resistant cross bar is not cut to fit or perforated in any way improving longevity of the rack.
- The Rear Roller Bar eases the loading and unloading of the rack. The Rear Roller comes standard with the 2 and 3 Bar racks.
- Available in our durable black or white powder coat paint.
- Optional center bars support shorter lengths and provide additional support.

Model	Description	Color
3BARRPM-B	3 Bar Utility Rack w/rear roller bar	Black
3BARRPM-W	3 Bar Utility Rack w/rear roller bar	White
2BARRPM-B	2 Bar Utility Rack w/rear roller bar	Black
2BARRPM-W	2 Bar Utility Rack w/rear roller bar	White
1BARRPM-B	1 Crossbar	Black
1BARRPM-W	1 Crossbar	White

80-1	Aluminum Conduit Carrier 10' 6"
80-2	Aluminum Conduit Carrier 12' 6"

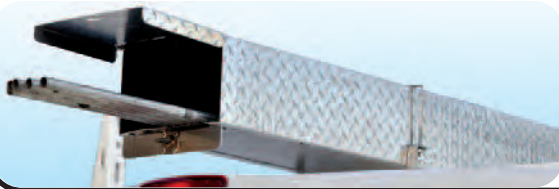

ALUMINUM CONDUIT CARRIER

The two piece design features a lift-up door with a spring assist for easy access and lockable swivel closure. Constructed with .063" diamond tread aluminum with a bolt-on plate at the front to allow access to the front end of the carrier.



C/V TRADESMAN gRIP-LOCK LADDER RACK



gRIP YOUR LADDERS SECURELY A gRIP-LOCK LADDER RACK.

Don't overlook the storage space on the roof of your RAM C/V. Adrian Steel's double lock-down Grip-Lock ladder rack can transport two ladders safely from jobsite to jobsite. Add padlocks for secure storage of your ladders.

64-MVCVN Double lock-down Grip-Lock rack with Ladder Extension shown.



gRIP-LOCK FEATURES AND BENEFITS

- Heavy-Duty actuating arm firmly grips ladder rungs to prevent shifting of ladder on rack.
- Gripping mechanism is lockable.
- Polymer adhesive pads protect ladder rails from contact damage on full-size van models.
- Rung grips easily adjust to accommodate different types of ladders.
- There are no straps to deal with, clamping of ladder is automatic.
- Mounts to pre-existing mounting points in roof. No drilling required.

GRIP-LOCK LADDER RACKS FOR RAM CV

- 61-MVCVN Single rack
- 63-MVCVN Double rack
- 64-MVCVN Combo rack





C/V TRADESMAN TRADE PACKAgES

4885 gENERAL SERVICE PACKAgE RAM CV 2012-ON

Item	Model	Description	Qty.
1	AD3232MV	ADseries Shelving 32"	2
2	BAG41485	Floor Reinforcement Kit	1
3	DV14C8	Divider Kit of 8	2
4	P2RCV	Partition for 2012-on CV	1
5	R3	Riser Kit	2
6	TA1	Four Hook Bar	1

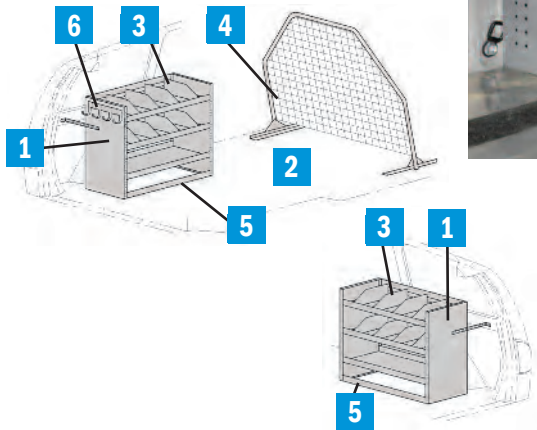

Organize your cargo with an Adrian Steel trade package specifically designed for the RAM C/V Tradesman. Divided shelving, drawers for small parts and a workbench are just a few of the options.

*Note: Adrian Steel interior cargo management solutions are not compatible with side curtain airbags.

4883 ELECTRICAL PACKAgE RAM CV 2012-ON

Item	Model	Description	Qty.
1	AD3232MV	ADseries Shelving 32"	2
2	BAG41485	Floor Reinforcement Kit	1
3	DC6	Drawer Component 6"	4
4	DV14C8	Divider Kit of 8	1
5	P2RCV	Partition for 2012-on CV	1
6	R3	Riser Kit	2
7	TA1	Four Hook Bar	1
8	WRH5	Wire Reel Holder	1
9	19	Two Drawer Medium	1
10	9	Four Drawer Shallow	1

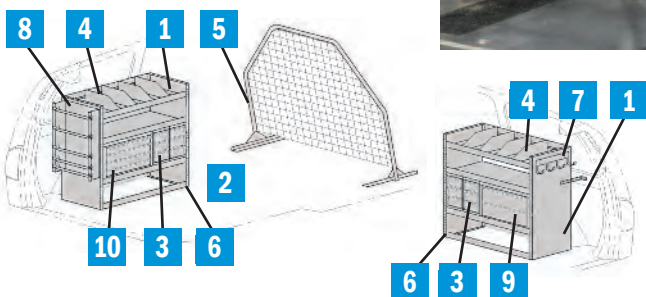

C/V TRADESMAN TRADE PACKAgES



4882 LOCKSMITH PACKAgE RAM CV 2012-ON

Item	Model	Description	Qty.
1	BAG41485	Floor Reinforcement Kit	1
2	MD525	Workbench Module 42"	1
3	P2RCV	Partition for 2012-on CV	1
4	R3	Riser Kit	1
5	08814-1	Mounting Bracket	1

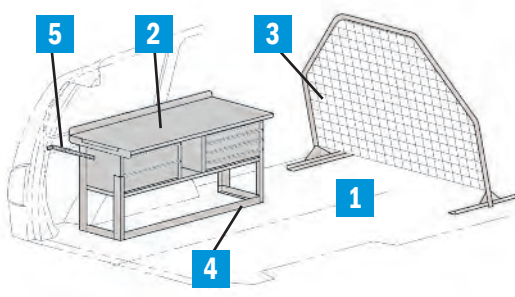
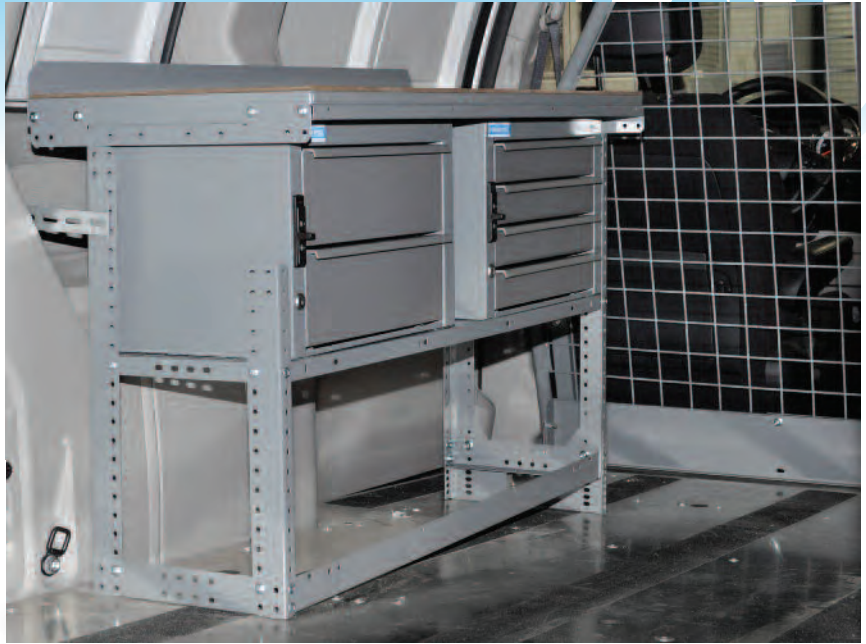

All packages include a combination of shelving, drawers, cabinets and a partition. Use these packages as starting points to customize your own package, or add a variety of accessories to the existing designs with hooks, drawer units and bins.

*Note: Adrian Steel interior cargo management solutions are not compatible with side curtain airbags.

4884 PHVAC PACKAgE RAM CV 2012-ON

Item	Model	Description	Qty.
1	AD3232MV	ADseries Shelving 32"	2
2	BAG41485	Floor Reinforcement Kit	1
3	DC6	Drawer Component 6"	7
4	DV14C8	Divider Kit of 8	1
5	P2RCV	Partition for 2012-on CV	1
6	R3	Riser Kit	2
7	TA1	Four Hook Bar	2
8	919	Three Drawer Combo	1

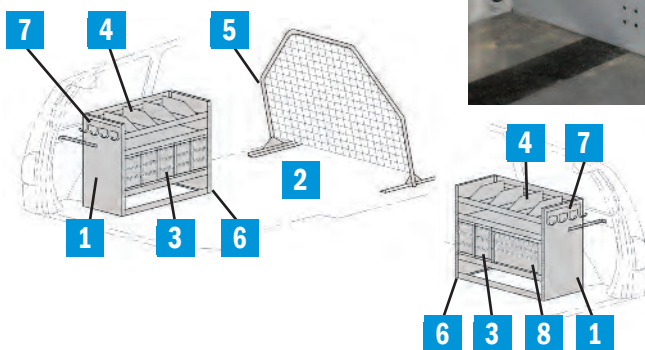

**PROMASTER PACKAGES
AVAILABLE SOON**

LOCATE YOUR DISTRIBUTOR

Home About Contact Us FAQ New Products Road - Redi Programs Catalogs News and Events Blog

ADRIAN STEEL
Cargo Management Solutions for Commercial Vehicles

New Vehicle Graphics Program
commercial Curb Appeal

Cargo Vans Pickup Trucks Cargo Trailers Walk-In Vans Vocational Upfits Distributor Locator Photo and Video Gallery

Distributor Locator

Advanced Search

Popular Links

- ADseries Shelving
- Van Ladder Racks & Pickup Racks
- Van Shelving
- Van Partitions & Bulkheads
- Pickup Trucks
- Van Accessories
- Cargo Vans
- Ladder Racks
- Transit Connect
- Van Storage

Testimonials

"Very happy with the shelving in our new show trailer. Makes things easier."

Jim
Westfield, NY

Add Testimonial

Adjust your search:

Zip/Postal Code: SEARCH

State/Province: Michigan

Full line stocking distributor Show Area Certified Technician on staff

Full line stocking distributor Show Area Certified Technician on staff Certified Sales Person on staff

1. Go to www.adriansteel.com/distributors
2. Search by Zip code or use the state drop-down listing
3. View distributor locations and contact information on the map and list to find the store nearest you!

INDEX

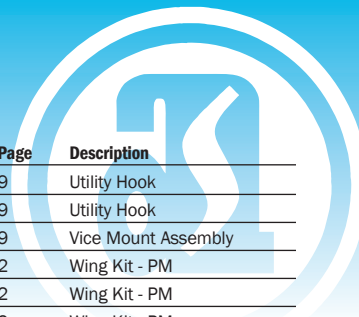

Model	Page	Description
ACT3	9	Aerosol Can Tray
ACT4	9	Aerosol Can Tray
AFD181236	8	Aluminum Floor Drawer
AFD241224	8	Aluminum Floor Drawer
AFD241236	8	Aluminum Floor Drawer
BH4	8	Binder Holder
BR36212	8	Bin System
BR76012	8	Bin System
BRK14EPS	5	End Panel Bracket
CB2	8	Two Book File
CB3	8	Catalog File
CB4	8	Utility Storage Box
CB5	8	Literature Holder
CB7	8	Literature Holder
CL1446D	6	Cabinet Locker
CL1446R	6	Cabinet Locker
CRH2	9	Cable Reel Holder
CS9	9	9" Cargo Strap
CS15	9	15" Cargo Strap
CS21	9	21" Cargo Strap
CS31	9	31" Cargo Strap
DC6	7	Drawer Component
DC12	7	Drawer Component
DK3008	5	8" Door Kit/HAD3259
DK3010	5	10" Door Kit/HAD3259
DK4208	5	8" Door Kit/HAD4459
DK4210	5	10" Door Kit/HAD4459
DK4808	5	8" Door Kit/HAD5059
DK4810	5	10" Door Kit/HAD5059
DS06112V	7	Drawer System
DS36012H	7	Drawer System
DS46012	7	Drawer System
DST21	9	Door Storage Tray
DT21	9	Door Tray
DTL21	9	Door Tray Lid
DTWL21	9	Door Tray w/Lid
DV14C1	5	Divider, Single
DV14C8	5	Divider, 8 Pack
HAD4459	4,5	HD Shelf 32"
HAD5059	4,5	HD Shelf 44"
HAD3259	4,5	HD Shelf 50"
KDRH1426	9	End Panel Reel Holder
KDRH1432	9	End Panel Reel Holder
KDRH1444	9	End Panel Reel Holder
KDRH1450	9	End Panel Reel Holder
KDRH2	9	Reel Holder
P2RCV	3	Wire Partition-C/V

Model	Page	Description
PA10	3	Practice Holder
PA5-2	3	Plexiglass Cover Panel
PA7	3	Triangle Reflecter Kit
PAB	3	Fire Extinguisher
PA9	3	First Aid Box Tray
PA11	3	Cab File Box
PDK1	3	Partition Door Kit
RKA1	5	Rail Kit Adapter
RKA3	5	Rail Kit Adapter
RKA4	5	Rail Kit Adapter
RKA919	5	Rail Kit Adapter
RKABRK1	5	Rail Kit Adapter
RKABRK2	5	Rail Kit Adapter
RKPMLWB	5	Rail Kit 159" WB PM
RKPMMLWB	5	Rail Kit 136" WB PM
RKPMWLWB	5	Rail Kit 159" ext WB PM
RKPSWB	5	Rail Kit 118" WB PM
S1M1C1PM	2	Partition PM
S1M1HC1PM	2	Partition PM
S1M2C1PM	2	Partition PM
S1M2HC1PM	2	Partition PM
S1M2C2PM	2	Partition PM
S1M2HC2PM	2	Partition PM
SBIN060614	8	6" Plastic Bin
SBIN120614	8	12" Plastic Bin
SBINDIV	8	Plastic Bin Divider
SPT-4	7	SP Tote/Combo
SPT-4P	7	SP Tote/Poly
SPT-4S	7	SP Tote/Steel
SPT-S	7	SPT Steel Tray
SPT-P	7	SPT Poly Tote
SRAILAD26	8	Bin Retention Rail 26"
SRAILAD32	8	Bin Retention Rail 32"
SRAILAD44	8	Bin Retention Rail 44"
SRAILAD50	8	Bin Retention Rail 50"
STP12G	9	Paint, Gray
STP12W	9	Paint, White
STP12B	9	Paint, Black
TA1	3,9	Hook Bar
TA2	9	Hard Hat Holder
TA3	9	Saw Holder
TA18	6	Propane Tank Cab.
TA19	6	CO2 Tank Cabinet
TA20	6	Mapp Gas Cabinet
TH30	3	Tank Holder 30 lb
TH50	3	Tank Holder 50 lb
UH10	9	Utility Hook

Model	Page	Description
UH25	9	Utility Hook
UH50	9	Utility Hook
VMA36	9	Vice Mount Assembly
WKC1PM	2	Wing Kit - PM
WKC1PM3	2	Wing Kit - PM
WKC1PMR	2	Wing Kit - PM
WKC1PMR3	2	Wing Kit - PM
WRH5	9	Wire Reel Holder
1	6	Cabinet
1A	6	Shelf
1BARRPM-B	10	Crossbar/Black
1BARRPM-W	10	Crossbar/White
2	7	Drawer Unit
2BARRPM-B	10	2 Bar Utility Rack
2BARRPM-W	10	2 Bar Utility Rack
3BARRPM-B	10	3 Bar Utility Rack
3BARRPM-W	10	3 Bar Utility Rack
4A	9	Parts Tray
4B	9	Parts Tray
8	7	Drawer Unit
9	7	Drawer Unit
12	6	Cabinet
12A	6	End Panel
14	9	Step Stool
17A	8	Six Shelf Catalog File
19	7	Drawer Unit
25	7	Divider/#2
26	7	Divider/#8
27	7	Divider/#19
43	8	Three Shelf Catalog File
60-129	9	Window Screen-PM
60-131	9	Window Screen-PM
60-PM-MLXW	9	Window Screen Kit-PM
61-MVCVN	11	Single Grip-Lock Rack-C/V
63-MVCVN	11	Double Grip-Lock Rack-C/V
64-MVCVN	11	ComboGrip-Lock Rack-C/V
80-1	10	10' Aluminum Conduit Carrier
80-2	10	12' Aluminum Conduit Carrier
919	7	Drawer Unit
4882	12	Locksmith Pkg - C/V
4883	12	Electrical Pkg - C/V
4884	12	PHVAC - C/V
4885	12	Gen Svc Pkg - C/V
35325-G	5	32" ADseries Add-on Shelf
35327-G	5	44" ADseries Add-on Shelf
35328-G	5	50" ADseries Add-on Shelf

ADRIAN STEEL COMPANY

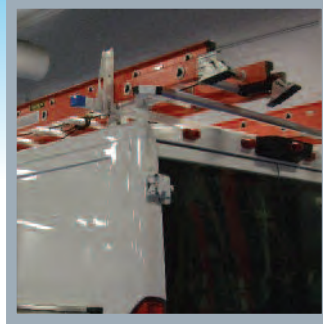
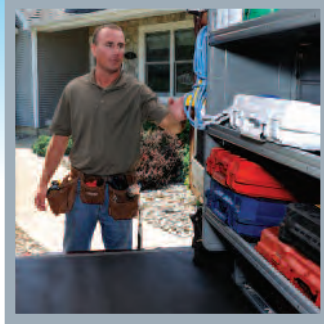

QUALITY

- Adrian Steel is proud to be the first and only van equipment manufacturer to obtain TS16949 certification.
- Our products are durable and reliable. Warranty claims are less than 1% of sales.
- Our warranty covers our products for three years or 36,000 miles.

INNOVATIVE PRODUCTS WITH FEATURES THAT MATTER

- Drawers that stay closed while in transit.
- ADseries truly adjustable shelving platform.
- Grip-Lock and Utility Rack options.
- Trade specific interior packages.
- Plug and Play accessories.
- File storage, removable small parts bins, and much more!



COMMITMENT

- At Adrian Steel, we are committed to you beyond the upfit!
 - A dedicated Customer Care Team at corporate headquarters.
 - A network of highly qualified distributors to support you locally.
 - Our commitment to provide the best cargo management solutions in North America.

EXPERIENCE

- **Over One Million vans upfitted**, and counting! It's a fact that an organized vehicle increases work flow efficiencies and reduces inventory damages.
- Recognized as a National Truck Equipment Association MVP.



SERVICE

- Adrian Steel Products can be purchased throughout North America at authorized Adrian Steel distributors.
- Adrian Steel Customer Service Representatives are available M-F, 8am - 5pm EST at **1-800-677-2726**.
- E-mail us at **info@adriansteel.com** with questions, comments and feedback.
- Visit **AdrianSteel.com** for the most up-to-date product information, distributor locator, product catalogs, videos and more.

PROUDLY DISTRIBUTED BY:



906 James Street
Adrian, Michigan 49221-3996
517-265-6194 Fax: 517-265-5834
Toll Free 800-677-2726
adriansteel.com info@adriansteel.com