



BOMAG
FAYAT GROUP

Combination Vibratory Roller **BW138AC-5**



KEY FEATURES

- 54" inch drum width
- 35.4" inch drum diameter
- 4 smooth pneumatic tires
- Kubota diesel engine
- Enhanced tractive effort
- ECONOMIZER
- Dual vibration frequency
- Double travel lever and sliding seat
- No daily grease points
- Foldable ROPS

www.bomag.com/us



Technical Specifications

BW138AC-5

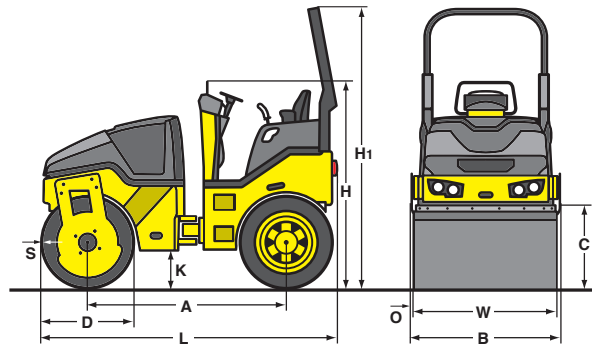

Shipping dimensions in cubic feet (m³)

BW138AC-5 398 (11.3)

Standard Equipment

- Hydrostatic travel and vibration drives
- Foldable ROPS with safety belts
- Suspended operator's platform
- Adjustable operator's seat
- Lateral sliding seat
- Seat with safety contact switch
- Double travel lever
- 2 flexible scrapers per drum
- Bolt-on oscillating/articulating joint
- Pressure water sprinkler system
- Water system interval switch
- Lockable engine cover
- Lockable dashboard cover
- Emergency stop button
- Working lights front/rear
- Fuel level indicator
- Hour meter
- Back-up alarm

Optional Equipment

- Economizer (Factory Installation)
- Rotary beacon
- Edge cutter
- Indicator and hazard lights
- Biodegradable hydraulic oil
- Special paint color

Dimensions in inches (mm)

	A	B	C	D	H	H ₁	K	L	O	S	W
BW138AC-5	74.8	57.9	27.6	35.4	74.8	106.3	13.4	111.8	1.7	0.7	54.3
	(1900)	(1470)	(700)	(900)	(1900)	(2700)	(340)	(2840)	(44)	(18)	(1380)

Technical Data

Weights

Operating weight w. ROPS CECE	lbs (kg)
Axle load drum CECE	lbs (kg)
Wheel load CECE	lbs (kg)

Driving Characteristics

Max. travel speed	mph (kmph)
Gradeability (with / without vibration)	%

Drive

Engine manufacturer + type	
Tier Compliance	
Cooling	
Number of cylinders	
Performance SAE J 1995 (ISO 14396)	hp (kW)
Speed adjustment 1	rpm
Speed adjustment 2	rpm
Electric equipment	V
Drive system	

Drum and Tires

Tire size	
Number of tires	

Brakes

Service brake	
Parking brake	

Steering

Steering system and method	
Steering / Oscillating angle +/-	degrees
Crab steer offset / Mechanical	in (mm)
Track radius, inner	in (mm)

Exciter system

Vibrating drum	
Drive system	
Frequency	vpm (Hz)
Amplitude	in (mm)
Centrifugal force (front drum)	lbs (kN)

Water spray system

Type	
------------	--

Capacities

Fuel	gal (l)
Water	gal (l)
Emulsion for tires	gal (l)

Technical modifications reserved. Machines may be shown with options.

BOMAG BW138AC-5

9039 (4100)
4630 (2100)
1102 (500)

0 - 6.2 (0 - 10)
30/40

Kubota V 2203
Tier 4i
water
4
45.3 (33.3)
2600
2300
12
hydrostatic

10.5 / 80-16
4

hydrostatic
hydromec.

oscil. / artic. / hydrostatic
32 / 13
2 (50)
103 (2616)

front
hydrostatic
3120 / 2520 (52 / 42)
0.02 (0.5)
11025 / 7200 (49 / 32)

pressure with interval

14.5 (55)
76.6 (290)
13.2 (50)

B861H-3625 2M1013TTTTCG