



BOMAG
FAYAT GROUP

Vibratory Tamper BT60 BT65 BVT65



3 KEY FEATURES OF THE BT60 AND BT65



Easy service: hour and rpm meter with integrated service indicator.



All around engine protection.



Dual air filter system helps extend the life of the engine.



Technical Specifications

BT60 BT65 BVT65

Shipping dimensions in cubic feet (m³)

BT60	19.3	(0.547)
BT65	19.3	(0.547)
BVT65	19.3	(0.547)

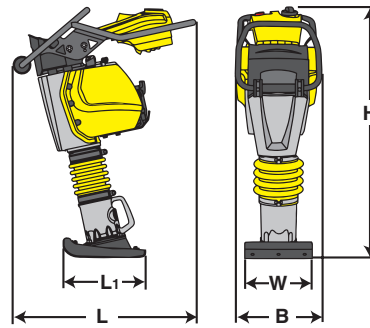

Dimensions in inches

	B	H	L	L ₁	W
BT60	13.8	37.4-40.6	28.6	13.2	9
BT65	13.8	37.4-40.6	28.6	13.2	11
BVT65	13.8	37.4-40.6	28.6	13.2	11

Standard Equipment

- 3-2-1 Warranty
- Reliable Honda 4-stroke engine
- Engine protection covers and guards
- Recoil starter with integral guard
- Splash oil lubrication
- Low engine oil alert
- Diaphragm carburetor
- Acceleration pump
- Hour / Tachometer with integrated service indicator (BT60, BT65)
- Corrosion-free plastic fuel tank
- Centrifugal clutch
- Infinitely variable frequency
- Vibration isolated steering handle
- Ergonomic height adjustable handle
- Easy access shut-down switch (fuel & engine combined)
- Dual air filter system (BT60, BT65)
- Single air filter system (BVT65)
- Self cleaning air filter housing
- Dual fuel filter system
- Polyethylene shoe with steel wear plate

Optional Equipment

- Transport wheels
- Interchangeable Shoe Kits
6", 9", 11", 13"
- 15" Tall Tamper Foot Extension Kits
4" or 6" shoe widths
- Hour / Tachometer with integrated service indicator (BVT65)
- Service kit

Technical data

	BOMAG BT60	BOMAG BT65	BOMAG BVT65
--	---------------	---------------	----------------

Weights

Basic weight lbs (kg)	125 (57)	147 (67)	140 (66)
Operating weight lbs (kg)	128 (58)	150 (68)	143 (67)

Driving characteristics (depending on site conditions)

Working speed max ft/min (m/min)	66 (20)	66 (20)	66 (20)
--	---------	---------	---------

Drive

Engine manufacturer	Honda	Honda	Honda
Type	GX 100 (4-cycle)	GX 100 (4-cycle)	GX 100 (4-cycle)

Fuel	gasoline	gasoline	gasoline
Number of cylinders	1	1	1
Performance ISO 9249 hp (kW)	3.4 (2.3)	3.4 (2.3)	3.4 (2.3)
Speed rpm	4200	4200	4200
Starting device	recoil	recoil	recoil
Fuel consumption max gal/h (l/h)	0.2 (0.8)	0.2 (0.8)	0.2 (0.8)

Vibratory System

Drive system	mechanical	mechanical	mechanical
Frequency bpm (Hz)	705 (10 - 11.8)	705 (10 - 11.8)	705 (10 - 11.8)
Impact force lbs (kN)	3372 (15)	3822 (17)	3597 (16)

Capacities

Fuel gal (l)	0.8 (3)	0.8 (3)	0.8 (3)
------------------------	---------	---------	---------

Technical modifications reserved. Machine may be shown with options.



BVT65 - Easy access shut down



BT60, BT65 - Easy access shut down