

# Technical Specifications

## Reversible Plates

### Shipping dimensions

in cubic feet (m<sup>3</sup>)

BPR35/60	30	(0.85)
BPR35/60D	30	(0.85)
BPR35/60D/E	30	(0.85)

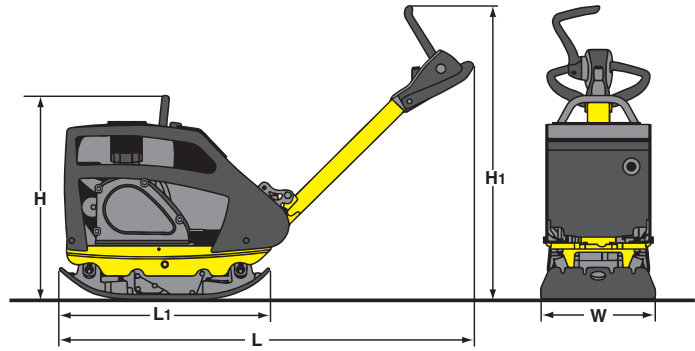

### Standard Equipment

- Fully enclosed engine protection hood made of high-strength grain-refined steel.
  - Hydraulic travel lever adjustment
  - Height adjustable steering rod
  - Steering rod lockable in transport and working position
  - Vibration and throttle regulation on the steering rod
  - Highly wear resistant base plate with reinforced edges
  - Fully protected V-belt
  - Reinforced centrifugal clutch
  - Automatically adjusting V-belt pulley
  - Recoil starter
  - Electric starter (BPR35/60D/E only)
- (BPR35/60D & BPR35/60D/E ONLY)**
- Semi-automatic decompression
- (BPR35/60 ONLY)**
- Large-volume dry air filter with cyclone-type precleaner
  - Automatic shutdown at low oil level

### Optional Equipment

- Transport wheels
- Service Kit
- Vulcolan mat

### Dimensions in inches (mm)

	H	H <sub>1</sub>	L	L <sub>1</sub>	W
BPR35/60	25.5 (647)	32.3 (820)	59.4 (1510)	30 (762)	23.6 (600)
BPR35/60D	27.1 (688)	32.3 (820)	59.4 (1510)	30 (762)	23.6 (600)
BPR35/60D/E	27.1 (688)	32.3 (820)	59.4 (1510)	30 (762)	23.6 (600)

### Technical Data

	BOMAG BPR35/60	BOMAG BPR35/60D	BOMAG BPR35/60D/E
--	-------------------	--------------------	----------------------

### Weights

Operating Weight .....	lbs. (kg)	470 (213)	525 (238)	569 (258)
Basic weight .....	lbs. (kg)	463 (210)	518 (235)	563 (255)

### Dimensions

Dimensions .....	see sketch	see sketch	see sketch
------------------	------------	------------	------------

### Driving Characteristics (depending on site conditions)

Working speed max .....	ft / min (m / min)	89 (27)	89 (27)	89 (27)
Max. gradeability .....	%	32	32	32

### Drive

Engine manufacturer.....		Honda	Hatz	Hatz
Type.....		GX160	1B20	1B20
Cooling.....		air	air	air
Number of cylinders .....		1	1	1
Performance ISO 9249 ....	hp (kW)	4.8 (3.6)	4.2 (3.1)	4.2 (3.1)
Speed .....		3600	3000	3000
Drive system .....		mech.	mech.	mech.
Fuel.....		gasoline	diesel	diesel

### Vibratory system

Frequency .....	vpm (Hz)	4800 (80)	4800 (80)	4800 (80)
Centrifugal force.....	lbs (kN)	7868 (35)	7868 (35)	7868 (35)

### Capacities

Fuel.....	gal (l)	1 (3.6)	0.8 (3)	0.8 (3)
-----------	---------	---------	---------	---------

Technical modifications reserved. Machines may be shown with options.

B564H-3597 2M1013TTPPG



**BOMAG**  
FAYAT GROUP

## Reversible Vibratory Plates BPR35/60, BPR35/60D, BPR35/60D/E



*The transport wheels allow for one-person movement around the jobsite.*



*The Vulcolan mat helps avoid damage to paving stone surfaces.*

