

IPPC 2132P

21.5" TFT Full HD 16:9 Heavy Industrial Panel PC with Intel® Atom™ D2550, 1.86GHz, Multi-Touch Screen, 4GB DDR3, 4 x USB, 2 x COM, and Fieldbus Module Installed

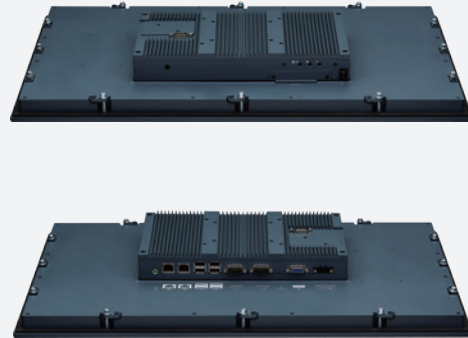

Main Features

- Intel® Atom™ D2550, Dual Core, low power consumption CPU
- Metal housing with robust aluminum front zero bezel for harsh environment
- Multi-touch P-Cap touch
- Dual GbE/2nd display-VGA/Line-in/Line-out/MIC-in
- USB x 4/2 x Mini-PCIe sockets/1 x CFast/2 x RS232/422/485
- Fieldbus enabled
- DDR3 4GB/2.5" HDD bracket
- IP66 compliant front panel
- Mounting support: Panel/Wall/Stand/VESA 100mm x 100mm
- Wide range power input 12V~ 30VDC

Product Overview

The 21.5" fanless panel PC IPPC 2132P incorporating an industrial motherboard is designed to meet up the demands of versatile industrial applications. The panel PC has a touch screen LED backlight LCD panel with 1920 x 1080 full-HD resolution. The front panel which adopts flush design and complies with IP66 standard makes it the perfect fit in industrial applications.

The IPPC 2132P supports WWAN/WLAN expansion and others via dual Gigabit Ethernet connectors, two Mini-PCIe slots and one SIM card holder. In addition, the wide power input range from 12V~30V makes IPPC 2132P gain a strong foothold in industrial field and machine devices. The IPPC 2132P also can connect to 2nd display via a VGA port for dual independent display. IPPC 1632P has two isolated RS232/422/485 ports, four isolated channels of DI and DO, and fieldbus ports.

Specifications

Panel

- LED Size: 21.5", 16:9
- Resolution: Full HD 1920 x 1080
- Luminance: 300cd/m²
- Contrast ratio: 5000
- LCD color: 16.7M
- Viewing Angle: 89(U), 89(D), 89(L), 89(R)
- Backlight: LED

Touch

- Ten points P-Cap (Projected Capacitive Touch)
- Touch light transmission: 87%
- Anti-scratch surface: 7H hardness
- Touch interface: USB

System

- CPU: on-board Intel® Atom™ Dual Core processor D2550, 1.86GHz, 1M L2 cache
- BIOS: AMI BIOS
- System chipset: Intel® NM10 Express chipset
- System memory: 2 x 204-pin DDR3 SO-DIMM socket, 4GB DDR3 (Default), support up to 4GB DDR3-800/1066, non-ECC and Un-buffered
- Storage device:
 - 1 x external locked CFast socket
 - 1 x hard drive bay: optional 1 x 2.5" SATA HDD or 1 x SATA DOM

- Watchdog timer: Watchdog timeout can be programmable by software from 1 second to 255 seconds and from 1 minute to 255 minutes (tolerance 15% under room temperature 25°C)
- H/W status monitor: Monitoring system temperature, and voltage
- Expansion: 2 x Mini-PCIe sockets (support optional Wi-Fi, 3.5G module or Fieldbus Card)
- Panel backlight control button: Increase brightness/decrease brightness/backlight on/off

Rear I/O

- Ethernet: 2 x RJ45
- 2nd display VGA port: 1 x DB15
- Audio port: 1 x Line-out; 1 x Line-in; 1 x MIC-in
- USB: 4 x USB2.0
- Power switch
- Reset button
- DIO w/ 2.5kv isolated:
 - 4 x Digital Input (source type)
 - Input Voltage (dry contact): Logic 0: close to GND
 - Logic 1: Open
 - Input Voltage: Logic 0: 3V max
 - Logic 1: +5V ~ +30V
 - 4 x Digital Output (sink type)
 - Output voltage: 3.6V ~ 5V
 - Sink current: 200 mA max. per channel

Dimension Drawing

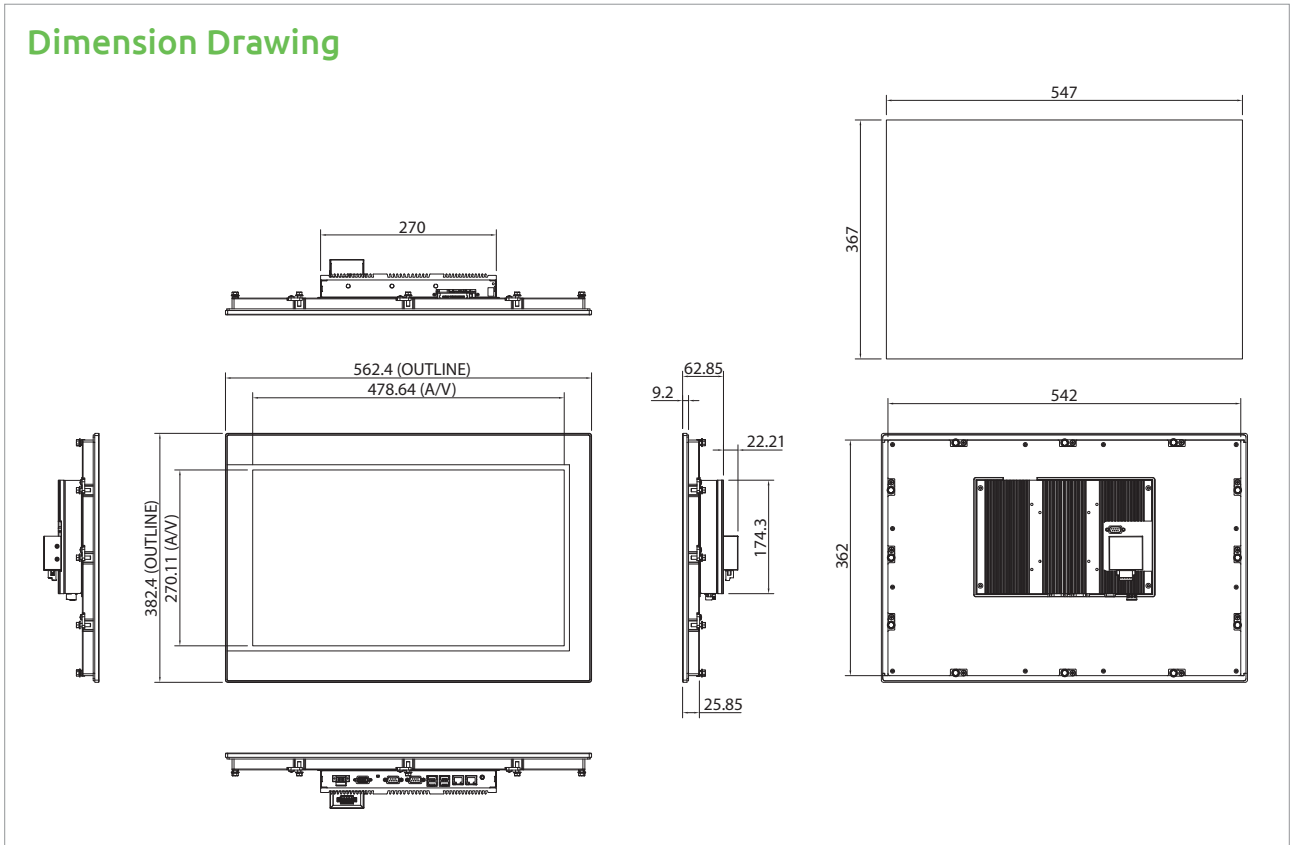

- COM #1: RS232/422/485 w/ 2.5kv isolated
- COM #2: RS232/422/485 w/ 2.5kv isolated
- Fieldbus: (protocol interface optional)

Model	Protocol	Connector
FBI90E-PNM	ProfiNET Master	Dual RJ-45
FBI90E-EP	Ethernet/IP Master	
FBI90E-ECM	EtherCAT Master	DB9
FBI90E-PBM	Profibus Master	
FBI90E-DNM	DeviceNet Master	5-pins Phoenix Contact Terminal

Audio

- AC97 codec: Realtek ALC886-GR
- Audio interface: Line-out/Line-in/MIC-in Audio Jack

Ethernet

- LAN chip: dual Intel® 82574L Gigabit LAN
- Ethernet interface: 10/100/1000 Based-Tx Ethernet compatible

Mechanical & Environment

- Color: pantone 425C\RAL 70 24 front bezel
- IP protection: IP66 front
- Mounting: panel/wall/stand/VESA 100mm x 100mm
- Power input: 12V~30VDC
- Power adapter: optional AC to DC power adaptor (+12V, 60W)
- Vibration:
 - IEC 68 2-64 (w/ HDD)
 - 1Grms @ sine, 5~500Hz, 1hr/axis (HDD Operating)
 - 2Grms @ sine, 5~500Hz, 1hr/axis (CFast Operating)
 - 2.2Grms @ random condition, 5~500Hz, 0.5hr/axis (Non-operating)
- Shock:
 - IEC 68 2-27
 - HDD: 20G@wall mount, half sine, 11ms
- Operating temperature: -10°C to 60°C
- Storage temperature: -20°C to 75°C
- Operating humidity: 10%~90% relative humidity, non-condensing
- Dimension: 562.4 x 382.4 x 62.85mm
- Weight: 9.26Kg

Certifications

- CE (including EN61000-6-2/EN61000-6-4)
- FCC Class B

Ordering Information

System

- **IPPC 2132P-FBI (P/N: A0I12132P00X0)**
21.5" Full HD LED Backlight Touch Panel PC, Intel® Atom™ D2550 1.86 GHz, touch screen, 4GB DDR3, 2 xRS232/422/485 and 4 x 4 DI/O with isolated protection, brightness adjustment buttons, fieldbus module installed
- **ProfiNET master interface: FBI90E-PNM for APPC (protocol option P/N: 88IA1932T00X0)**
- **Ethernet/IP interface: FBI90E-EP for APPC (protocol option P/N: 88IA1932T01X0)**
- **EtherCAT master interface: FBI90E-ECM for APPC (protocol option P/N: 88IA1932T02X0)**
- **Profibus master interface: FBI90E-PBM for APPC (protocol option P/N: 88IA1932T03X0)**
- **DeviceNet master interface: FBI90E-DNM for APPC (protocol option P/N: 88IA1932T04X0)**

Options

- **12V, 60W AC/DC power adapter w/o power cord (P/N: 7400060019X00)**