

Curriculum topics:

- Earthquakes
- Plate Tectonics
- Richter Scale
- Structures
- Vibration
- Circuits

Subjects:

**Physical Science,
Earth/Space Science**

Grade range: 2 – 12

Who we are:

Resource Area for Teaching (RAFT) helps educators transform the learning experience through affordable “hands-on” activities that engage students and inspire the joy and discovery of learning.

For more ideas and to see RAFT Locations

www.raft.net/visit-raft-locations

MOTORIZED SHAKE TABLE

Model an earthquake on a small scale

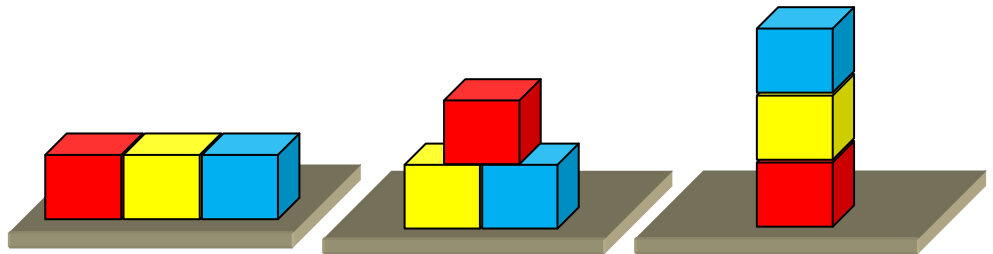

Build a simple structure on the shake table, start the motor, and watch the action! Will your building design survive the “earthquake”?

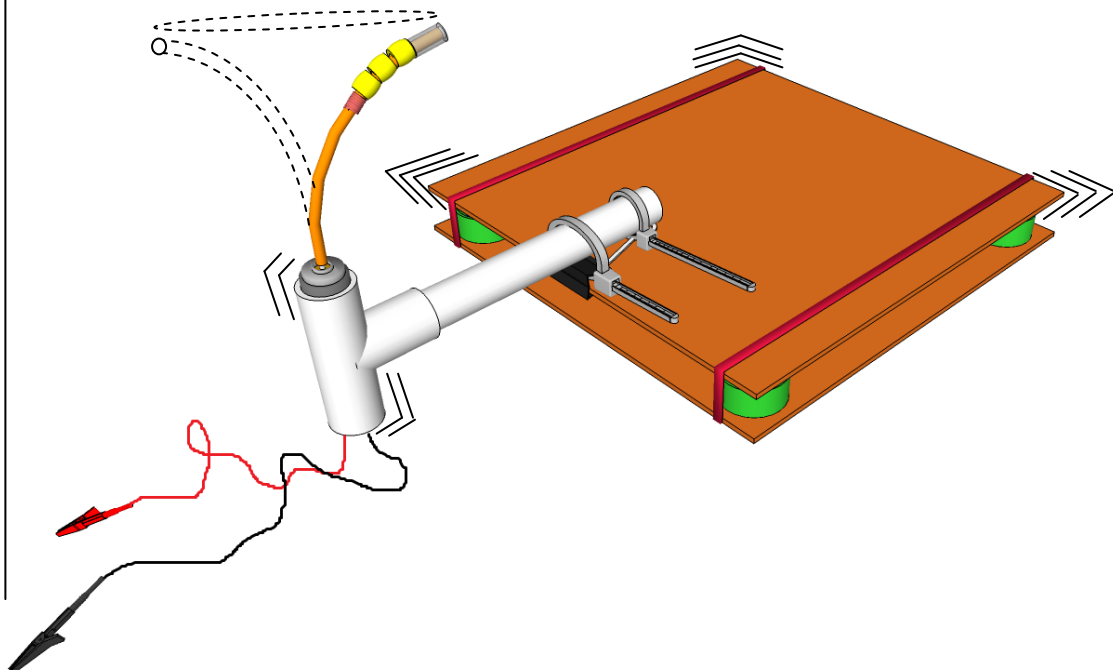

Materials required

Per Motorized Shake Table unit:

Note: OD = Outside Diameter
ID = Inside Diameter

- Plastic pipe, 1/2" nominal size, Schedule 40, ~13 cm (5") long
- Plastic Tee fitting for 1/2" pipe
- Motor, 1 1/2 to 3 volts, ~1.9 cm (3/4") dia. The motor needs to fit tightly into the Tee. If the fit is loose, wrap tape around the motor.
- Long tube, ~3 mm OD x 1.5 mm ID x 10 cm long (1/8" OD x 1/16" ID x 4" long). Long tube needs to fit tightly on the motor shaft
- Short tube, ~3 mm ID x 13 mm long (1/8" ID x 1/2" long). Short tube needs to fit tightly on the end of the long tube
- Small rubber band
- Beads, ~8 mm (~1/3") in diameter, 3 or 4
- Alligator test leads, each a different color, ~30 cm (12") long, 2
- Stiff cardboard, wood, or covers from binders ~30 cm x 30 cm (12" x 12"), 2
- Binder clip, medium
- Zip ties, releasable preferred, ~13 cm (5"), 2
- Rubber balls ~2.5 cm (~1"), 4
- Cap, which will hold a rubber ball, 4
- Large rubber bands, 14 cm (5 1/2") , 2
- Battery holder and 2 batteries
- Eye protection
- Blocks, wood or foam, 3 or more
- Optional: Foam block, ~2.5 cm x 5 cm x 10 cm (1"x2"x4") or other small shapes to test

Safety tip:

Wash hands after touching electrical components such as motors and wires.

How to build it

Note: Some students may need assistance with the **How to build it** steps. If needed, steps could be done in advance by an adult.

Assemble the Shaker Unit

- 1** Push plastic pipe firmly into the center of the tee fitting.
- 2** Push the long tube onto the motor shaft, leaving a small gap. Loop a small rubber band tightly around the tube, add 3 or 4 beads, and cap with the short tube as shown. Tug on the tube to make sure it is firmly on the motor shaft.
- 3** Attach the wires to the motor, and then run the wires through the tee as shown
- 4** Push the motor into the end of the tee as shown.

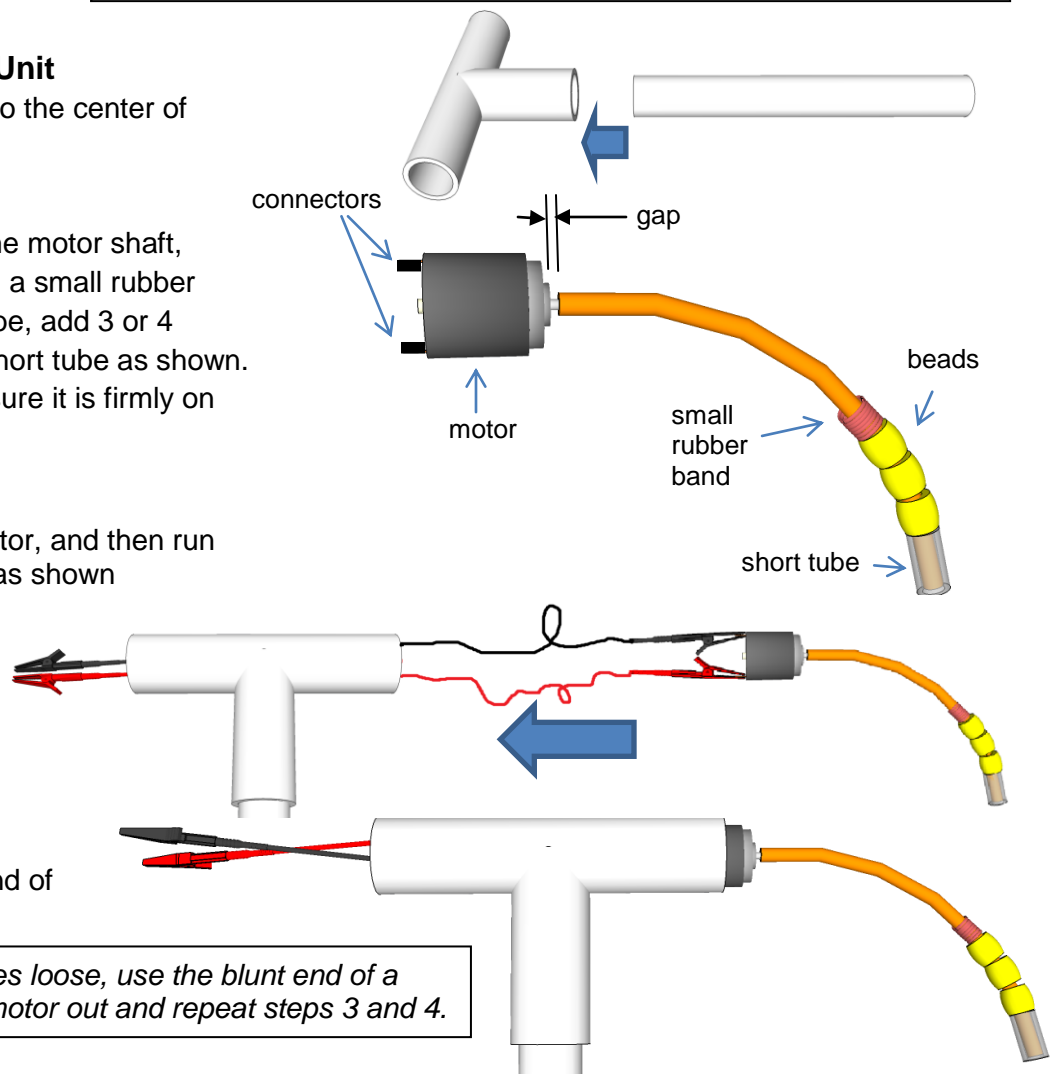

Teacher tip: If a wire comes loose, use the blunt end of a pen or pencil to push the motor out and repeat steps 3 and 4.

Attach the Shaker Unit to the Board

- 5 Attach binder clip to board as shown.



- 6 Slide a zip tie through the clip with the small ridges on the tie facing up. Put the ends together to create a large loop (do not pull tight).

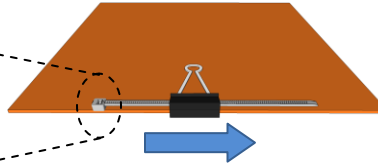
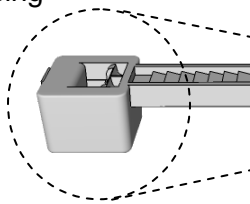

- 7 Slide the pipe through the loop and tighten the zip tie. Note: end of pipe is at the end of the handle.

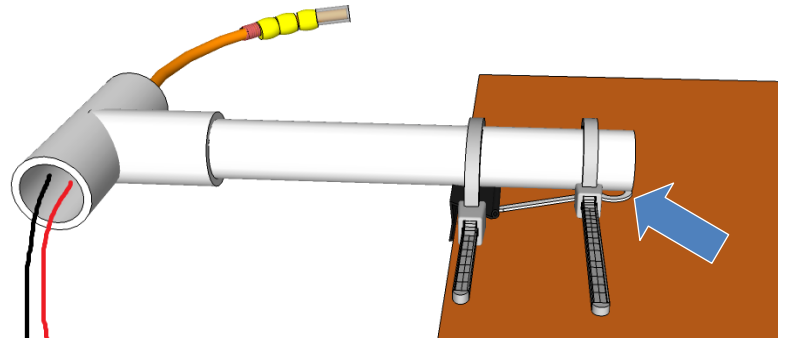

- 8 Add a second zip tie around the pipe and the narrowest part of the handle of the binder clip, as shown. Pull it tight, and then rotate the tee so the motor points up.

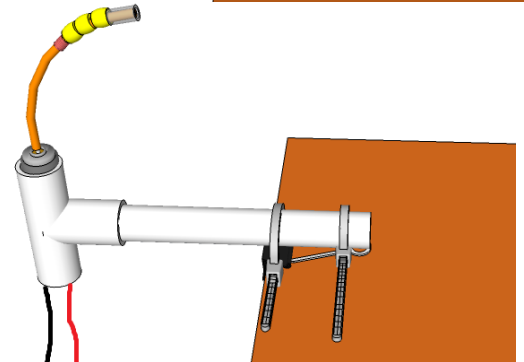
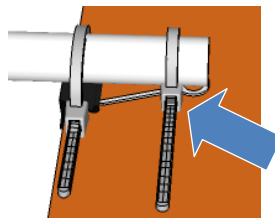

Complete the Shake Table

- 9 Put a ball in each of the four caps. Place a cap at each corner of the unused board, as shown.



- 10 Put the board with the shaker on top of the balls.

- 11 Stretch two large rubber bands around the whole shake table to hold it together. Center the rubber bands over the balls in the caps.

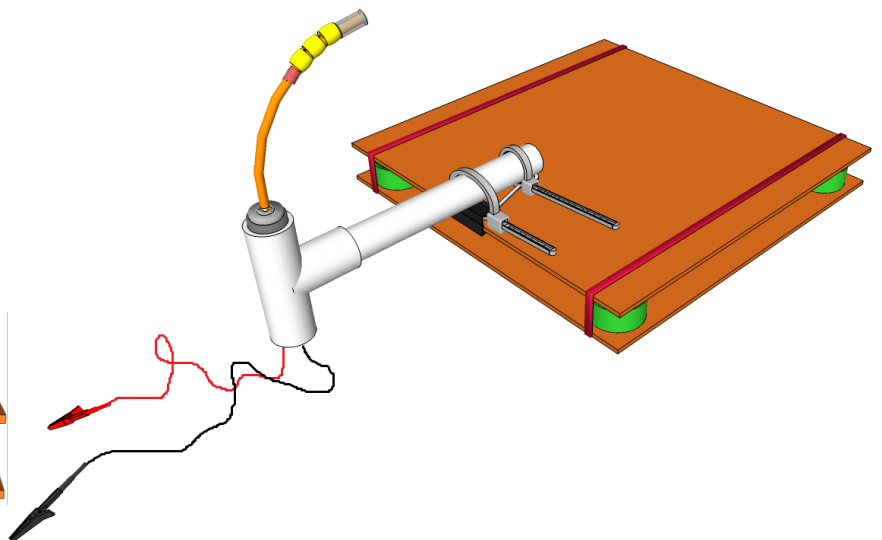
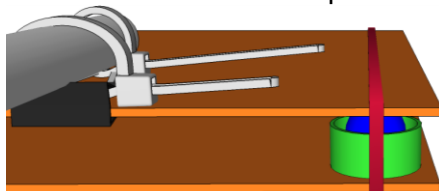

Curriculum Standards:

Forecast catastrophic events
(Next Generation Science Standards: Middle School, Earth and Space Science 3-2)

Geoscience process on Earth's surface
(Next Generation Science Standards: Middle School, Earth and Space Science 2-2)

Forces & Motion
(Next Generation Science Standards: Grade 3, Physical Science 2-1 & 2-2)

Energy can be converted between forms
(Next Generation Science Standards, Grade 4, Physical Science, 3-4);

Waves
(Next Generation Science Standards: Grade 4, Physical Science, 4-1)

Compare solutions, Combine designs
(Next Generation Science Standards: Engineering Design, Grades K-2, 1-3; Grades 3-5, 1-2; Middle School, 1-2, 1-3, & 1-4),

Design criteria & Test variables
(Next Generation Science Standards: Grades 3-5, Engineering Design, 1-1 & 1-3)

Science & Engineering Practices
(Next Generation Science Standards: Grades 2 – 12)

Additional standards at: <http://www.raft.net/raft-idea?isid=688>

To do and notice

Safety tip: Wear eye protection when using Motorized Shake Table. Avoid contact with spinning parts.

- 1 Attach the wires to the battery holder. The motor shaft will spin, causing the platform to shake. If the shaft does not spin, check the batteries and connections. To turn off the shaker, disconnect one wire.
- 2 Build one of the simple block structures shown on page 1. Notice what happens when the platform shakes. Repeat for other structures. Which design is most stable in an earthquake?

The science behind the activity

The force of an earthquake travels through the Earth in waves.

Surface Waves occur close the surface.

Body Waves happen deep inside the Earth

- **Primary Waves** (P-waves) are fast-moving body waves that compress the earth in front of them as they travel.
- **Secondary Waves** (S-waves) are body waves that radiate force in all directions.
 - **Love Waves** are S-waves that cause the side-to-side motion that damages many buildings.
 - **Raleigh Waves** are S-waves that cause both up-and-down and side-to-side motion. They are similar to the waves in the ocean.

In the Motorized Shake Table, the vibration created by the spinning tube and beads mimics the side-to-side movement created by **Love waves**. (For more on the science of vibration, see the RAFT Idea Sheet [Solar Jitterbug](#)).

Learn more

- Create a bed of “Grape Nuts” cereal (or other fine-grain material) under a structure and observe the effect of soil conditions on building stability.
- Mix cornstarch and water to model “liquefaction” (See RAFT Idea Sheet [Ooh, Ooh, Oobleck](#) for a recipe).
- Use other materials to construct buildings, such as straws and chenille stems or toothpicks and marshmallows. What happens to taller buildings?

Related activities: See RAFT Idea Sheets:

Foam Faults - <http://www.raft.net/ideas/Foam Faults.pdf>

Shake Table - <http://www.raft.net/ideas/Shake Table.pdf>

Your Room in an Earthquake -

<http://www.raft.net/ideas/Your Room in an Earthquake.pdf>

Resources

Visit www.raft.net/raft-idea?isid=688 for “how-to” video demos & more ideas!

See these websites for more information on the following topics:

- **Types of earthquake waves** - <http://www.allshookup.org/quakes/wavetype.htm>
- **Model seismic waves with a slinky** - <http://www.exploratorium.edu/faultline/activezone/slinky.html> and <http://web.ics.purdue.edu/~braile/edumod/slinky/slinky.htm>