

# Winston Workstation™

Sit-Stand Workstation



## Winston Workstation™ –

**Energizing your body. Inspiring your mind.**

Instantly converts any desk into a sit stand workspace boosting health and productivity.

Recent studies have shown that sitting throughout the day can have the same negative health consequences as smoking. Winston seamlessly integrates into your workday for a boost in health and wellness.

## FEATURES

- ▲ Take the work out of adjusting and replacing monitors. Simply attach, adjust, and remove all at the face of the beam. No need to slide monitors to remove.
- ▲ Designed to accommodate standing work without the distraction of unwanted movement.
- ▲ Large natural wood surface and convenient storage tray allow you to bring all necessities with you when you stand.
- ▲ Retrofit your existing desk into a healthy workspace with two easy mounting options: freestanding or desk clamp.
- ▲ Features a 17" range of vertical height adjustment and a locking cylinder to keep the workstation in place. No manual adjustment needed.
- ▲ Cable clips in the column and beam keep the cables organized and out of the way.
- ▲ Winston is assembled in the USA using components created through a green manufacturing process.



Seamless height adjustment



Engineered for stability



Single monitor option available



Cable management



Expansive work surface features a storage tray —keeps items within reach

# Winston Workstation™

Specifications

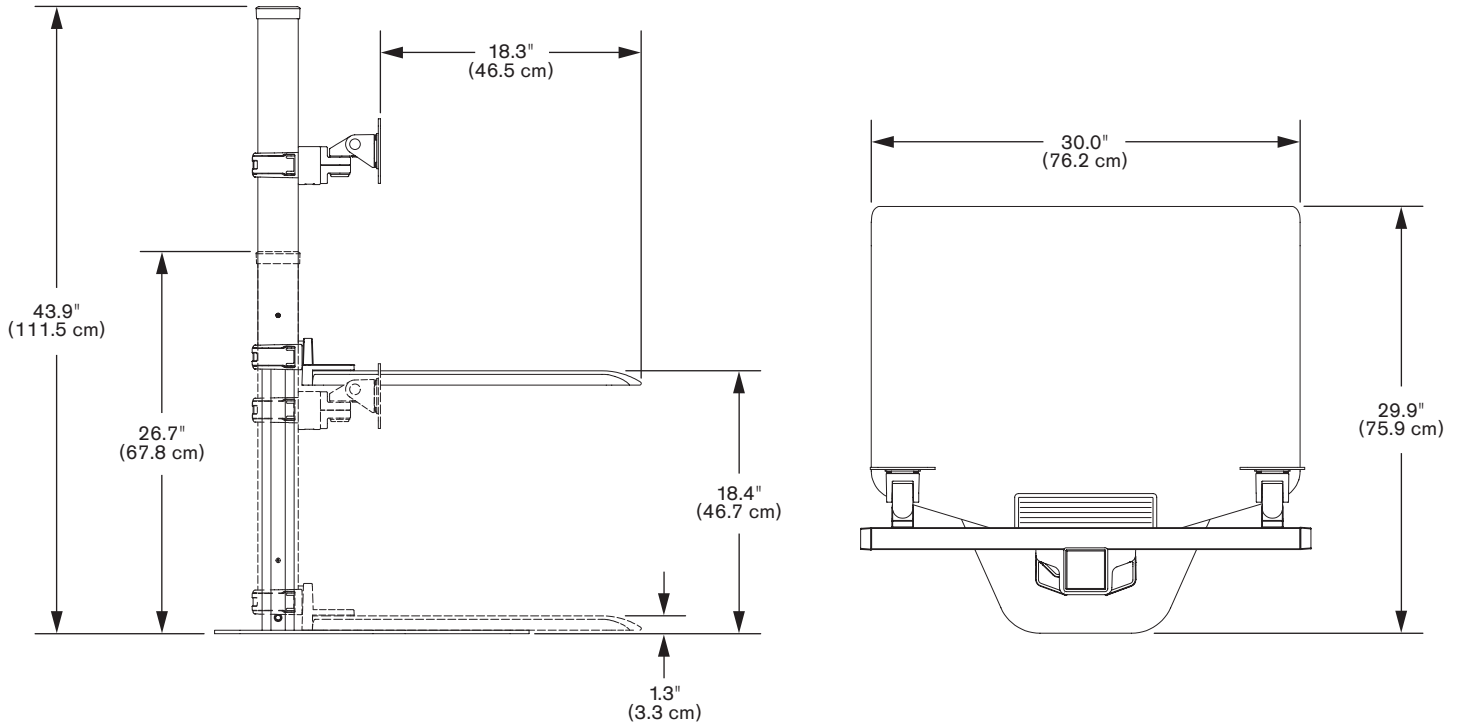

## CAPABILITIES

- Vertical height adjustment**..... 17" (43.2 cm)
- Monitor tilt**..... 200 degrees
- Monitor pivot**..... Landscape to portrait
- Monitor compatibility**..... VESA® 75mm and 100mm
- Cable management**..... Cables are clipped to column

## MONITOR WEIGHT RANGES

### Winston Workstation™ Single

- WNST-1-FS-L..... Supports 5 - 16 lbs (2.3 - 7.3 kg) per monitor
- WNST-1-FS-M..... Supports 12 - 28 lbs (5.4 - 12.7 kg) per monitor
- WNST-1-FS-H..... Supports 24 - 44 lbs (10.9 - 20 kg) per monitor

### Winston Workstation™ Dual

- WNST-2-FS-L..... Supports 0 - 6 lbs (0 - 2.7 kg) per monitor
- WNST-2-FS-M..... Supports 4 - 12 lbs (1.8 - 5.4 kg) per monitor
- WNST-2-FS-H..... Supports 10 - 20 lbs (4.5 - 9.1 kg) per monitor

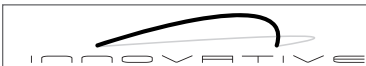

Phone: 800.524.2744 | Fax: 610.253.9521 | E-mail: sales@LCDarms.com | Web: www.LCDarms.com