

AGA Professional

48" Gas Range with RapidBake Convection™

APRO48AGSS



Oven Features

- Two ovens totaling 6.7 cubic ft. of oven capacity - 30" Extra Large oven has 4.2 cubic ft. and 18" oven has 2.5 cubic ft.
- RapidBake Convection™ speeds 350°F pre-heat time in 10 minutes
- Easy Clean™ Technology with black vitreous enamel interior
- Cool Flow™ Technology integrated automatic cooling system clears hot air making range surface cooler to touch
- Powerful infrared convection oven Broiler with Porcelain enameled broiler pan with grid
- Both ovens includes 3 oven racks and has 5 rack positions
- 30" Convection oven uses two long-lasting halogen bulbs and 18" Conventional oven uses 1 long-lasting halogen bulb for optimal illumination while cooking



Cooktop Features

- True Dual Flame™ double ring brass burners eliminate center cold spots and provide the most even heating
- One Stainless Steel Griddle (18"H x 11.25"W) with a 3.5"H grease catch for easy cleaning
- Griddle cover creates additional workspace when griddle not in use
- Continuous, easy-to-clean matte finish cast iron grates



Cooktop Specifications

- 3 - 15,000/700 Btu
- 3 - 12,000/2,800 Btu
- 1 - 15,000 Btu



AGA Kitchen Concierge
800-525-5601

#AGAProPower

www.aga-ranges.com

AGA Professional

48" Gas Range with RapidBake Convection™

APRO48AGSS



Technical Details

Circuit Breaker (A)	15A
Volts (V)	120v
Frequency (Hz)	60 Hz
Plug Type	120V 3-prong
Power Cord Length	5 ft.
Energy Source	Gas
Gas Type	Natural Gas
Alternative Gas Type	Liquid Propane LP Conversion Kit Included

Dimensions & Weights

Overall Dimensions	30"W x 27 1/2"D x 48"H (39 3/4"H to top of back splash)
Weight	266 lbs.
Shipping Weight	348.5 lbs.

Accessories Included

- 1 - Porcelain enameled broiler pan with grid
- 1 - Broiler pan insert
- 3 - 30" Oven Racks
- 3 - 18" Oven Racks
- 1 - Griddle Cover
- LP Conversion Kit

General Properties

Oven Capacity	6.7 cu. ft.
Cooking Modes - Main Cavity	Bake, Convection Bake, Broil
Cooking Modes - Second Cavity	Bake
Lighting	Long-lasting Halogen Bulbs; 2 Main and 1 Second
Cleaning Type	EasyClean™ Vitreous Enamel
Grate Type	Continuous Cast Iron
Controls	Die Cast Metal Knobs
Sealed Burners	Yes

Oven Performance

Convection Bake Power	22,000 BTU (NG)
Bake Power	14,000 BTU (NG)
Broiler Power	16,5000 BTU (NG)
Broiler Type	Infrared

Cooktop Performance

Number of Burners	6
Power of Front Left Burner BTU	15,000 Btu High 700 Btu Low
Power of Back Left Burner BTU	12,000 Btu High 2,800 Btu Low
Power of Front Center Burner BTU	15,000 Btu High 700 Btu Low
Power of Back Center Burner BTU	12,000 Btu High 2,800 Btu Low
Power of Front Right Burner BTU	15,000 Btu High 700 Btu Low
Power of Back Right Burner BTU	12,000 Btu High 2,800 Btu Low

Griddle Performance

Location of Griddle	Left Center
Power of Griddle	15,000 Btu Gas
Griddle Dimensions	18"D x 11 1/4"W with 3 1/2" Grease Trap

Warranty

2 Years Warranty, Entire Appliance, Parts and Labor



AGA Kitchen Concierge
800-525-5601

#AGAProPower

www.aga-ranges.com

AGA Professional

48" Gas Range with RapidBake Convection™

APRO48AGSS

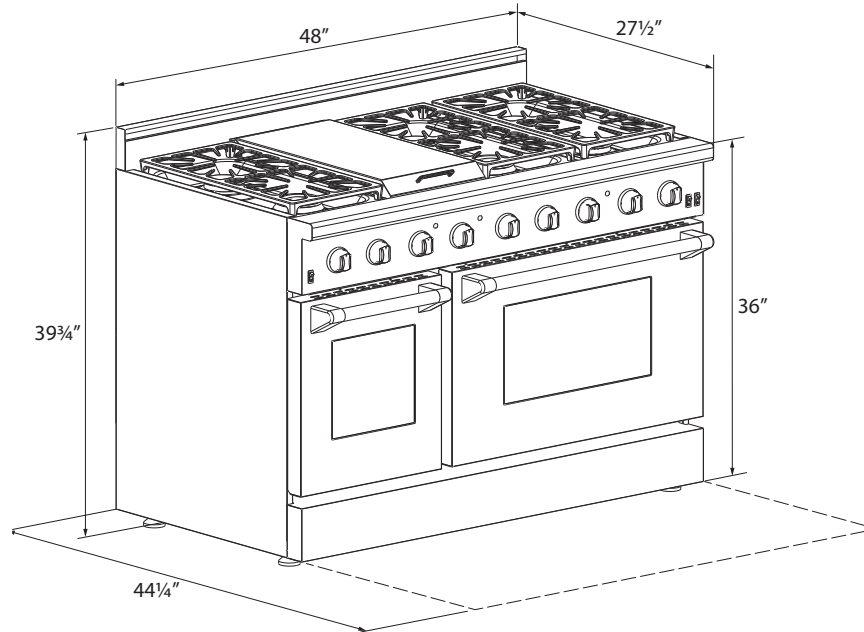

Standard Installation

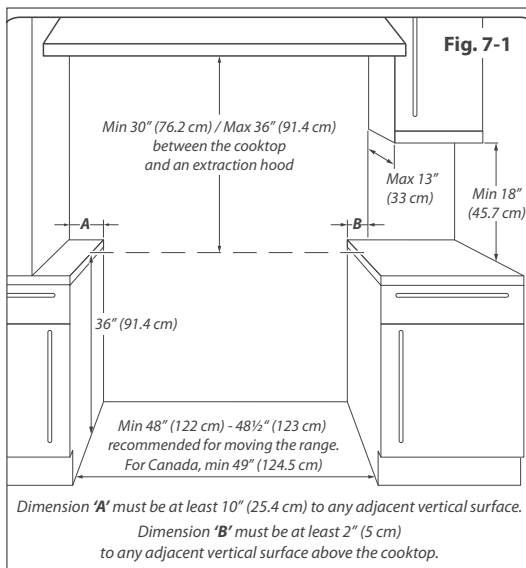

Electrical Connection

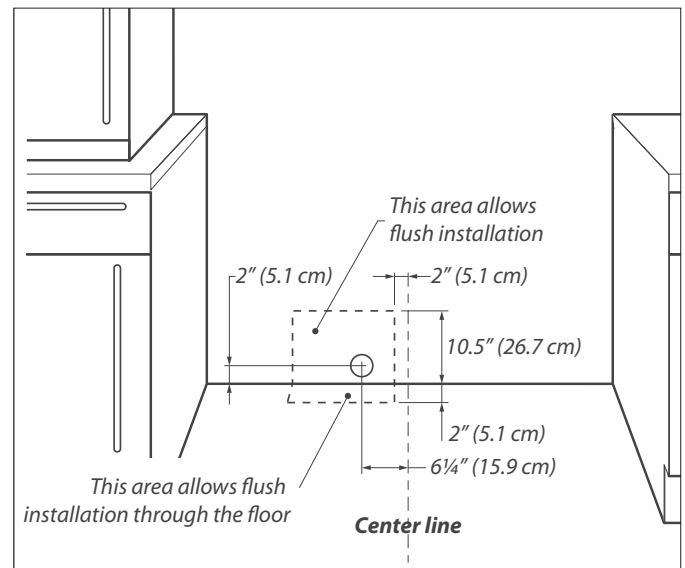

AGA Kitchen Concierge
800-525-5601

#AGAProPower

www.aga-ranges.com