



**DesignFlo® (DFL)**  
This architectural supply linear slot diffuser features aluminum extrusions with 1 or 2 slots from 1" to 3" slot widths. Custom curving is available.

- **DFL** - Linear
- **DFP** - Plenum
- **DFRH** - Return Hood
- **DFBO** - Blank Off
- **DFB** - DFL for Lay-in T-Bar
- **DFNT** - DFL for Narrow-T
- **DFMC** - Mitered Corner
- **DFC** - 4-Legged Junction
- **DFT** - 3-Legged Junction



**1900, 1900M, 1900BOOT**  
This supply linear slot diffuser features aluminum extrusions with 1 to 8 slots from 1/2" to 2" slot widths. Custom curving and additional slots are available.

- **1900** - Linear
- **1900BOOT** - Boot
- **1900MC** - Mitered Corner

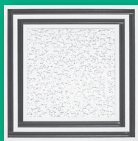

**1900SQS, 1900SQSI, 1900SQR**  
These supply (1900SQS), return (1900SQR), and insulated supply (1900SQSI) linear slot diffusers feature linears in a square form with a ceiling tile center (by others).

**DesignFlo® DFL, DFP, DFRH, DFBO, DFB, DFNT, DFMC, DFC, DFT**

Introduction .....	E1-3
Frame Styles.....	E1-4
End Borders .....	E1-6
Accessories (DFP, DFRH, & DFBO).....	E1-7
Reference Charts.....	E1-13
Performance Data.....	E1-14
DFB & DFNT Dimensional Information .....	E1-16
DFB & DFNT Reference Charts.....	E1-17
DFB & DFNT Performance Data.....	E1-19
Transitions & Mitered Corners (DFC, DFT, & DFMC) .....	E1-31
Engineering Specifications.....	E1-32

**1900, 1900MC, 1900BOOT**

Introduction .....	E1-40
Frame Styles.....	E1-41
Airflow Adjustment .....	E1-50
Accessories (1900BOOT & Mitered Corners).....	E1-51
TechZone® Frame Styles .....	E1-52
TechZone® Accessories .....	E1-53
Length & End Border Details .....	E1-54
Reference Charts.....	E1-55
Performance Data.....	E1-59
Engineering Specifications.....	E1-74

**1900SQS, 1900SQSI, 1900SQR**

Introduction & Dimensional Information .....	E1-77
Series Airflow Adjustment & Reference Charts.....	E1-79
Series Performance Data.....	E1-82
Engineering Specifications.....	E1-88

*TechZone® is a registered trademark of Armstrong®.*

## Introduction: DesignFlo® (DFL)

The DesignFlo® is a versatile, high performance, high capacity linear slot diffuser system. It is designed to work with many ceiling types and blend with any architectural interior space. DesignFlo® is unlike conventional linear diffuser systems in that it is designed to integrate with the ceiling system.

With an array of frame styles, mounting options, and the ability to be curved along any architectural plane, the DesignFlo® can be configured to produce continuous, flowing runs that blend with the interior space. This provides a great deal of freedom to architects who prefer that the air distribution system reflect the building design rather than restrict it.

The DesignFlo® is available with two types of pattern controllers which easily slide in permanently self lubricating plastic bridges, HT (Horizontal Throw) and VT (Vertical Throw). The HT pattern controllers direct air to the left, right, or downward and project in tight ceiling patterns with long throws. A unique feature of the HT pattern controller is the fact that it consists of two sliding blades. This offers not only pattern control, but volume control as well, making it an excellent choice for VAV systems. The VT pattern controller directs the airstream perpendicular to the diffuser face. In ceiling applications, this is useful where vertical projection is required, such as a perimeter zone with large windows. In a sidewall application, the VT controllers offer long throws.

### MODELS

- DFL - Architectural Linear Slot, Aluminum Extrusion
- DFP - Plenum for DFL
- DFRH - Return Hood for DFL
- DFBO - Blank-off for DFL
- DFB - DFL and DFP Combination Using Frame AC or CC for a Frame 23 T-Bar Application
- DFNT - DFL and Plenum Combination Using Frame AA for a Frame 98 T-Bar Application
- DFMC - Mitered Corner for DFL
- DFC - 4-Leg Junction
- DFT - 3-Leg Junction

### FEATURES

- Slot widths of 1" (DFL10), 1 1/2" (DFL15), 2" (DFL20), 2 1/2" (DFL25), and 3" (DFL30).
- Maximum single section length of 12'; able to be joined to create long, continuous runs.
- Integral pattern controllers constructed on 24" centers.
- Pattern controllers are removed or installed through face of diffuser.

### OPTIONS

- Optional mounting brackets.
- Optional spline support.
- Optional upper support hanger.

### ACCESSORIES

- Custom curving.

### FINISHES

- Standard finish is #44 British White or Black (dependent on frame style).
- Optional finishes available.
- Optional anodizing available.



**DFL Frame Styles: 1-Slot**

**DFL, 1-SLOT, FRAME AA**

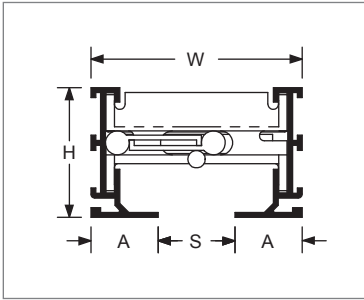

**DFL, 1-SLOT, FRAME AC**

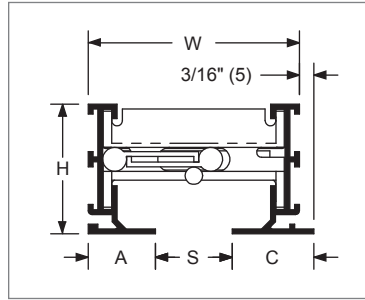

**DFL, 1-SLOT, FRAME BB**

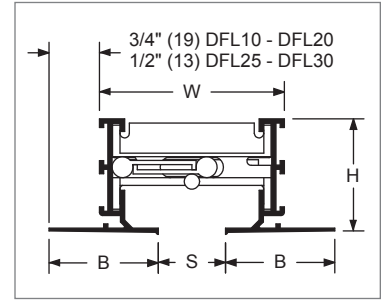

**DFL, 1 SLOT, FRAME AD\*\***

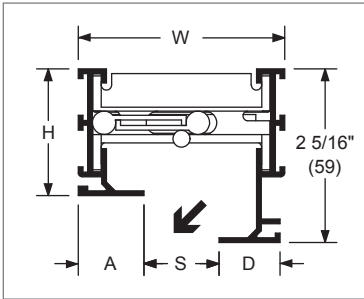

**DFL, 1-SLOT, FRAME CC**

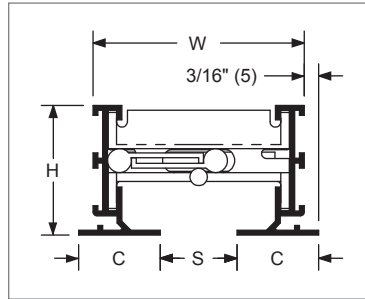

**DFL, 1-SLOT, FRAME FF**

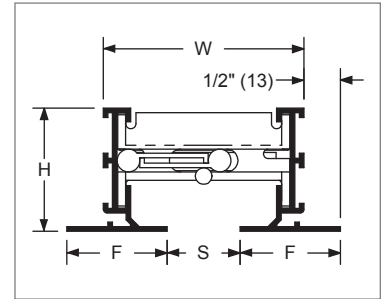

**DFL, FRAME DIMENSIONAL DETAIL**

Slot Width	Width					Stack		
	S	A	B	C	D	F	Width W	Height H
1"		7/8" (22)	1 5/8" (41)	1 1/16" (27)	7/8" (22)	1 3/8" (35)	2 3/4" (70)	1 11/16" (43)
1.5"		1 1/8" (29)	1 7/8" (48)	1 5/16" (33)	1 1/8" (29)	1 5/8" (41)	3 3/4" (95)	1 11/16" (43)
2"		1 3/8" (35)	2 1/8" (54)	1 9/16" (40)	1 3/8" (35)	1 7/8" (48)	4 3/4" (121)	1 11/16" (43)
2.5"		1 5/8" (41)	2 1/8" (54)	1 13/16" (46)	-	2 1/8" (54)	5 3/4" (146)	2 5/16" (59)
3"		1 7/8" (48)	2 3/8" (60)	2 1/16" (52)	-	2 3/8" (60)	6 3/4" (171)	2 5/16" (59)

NOTES: Dimensions in parentheses are mm. Dash indicates not applicable.

\*\* Frame AD only available in 1 Slot with HT Pattern Controllers; 1 1/2", or 2" Slot Widths.

**DFL Pattern Controllers: 1-Slot**

**DFL, 1-SLOT HT ADJUSTMENT 1**

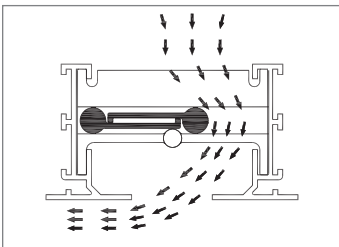

**DFL, 1-SLOT HT ADJUSTMENT 2**

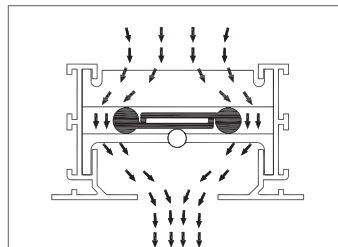

**DFL, 1-SLOT HT ADJUSTMENT 3**

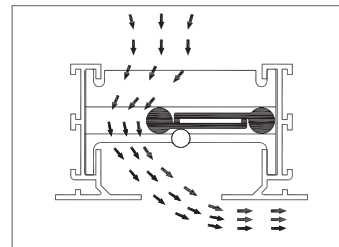

**DFL, 1-SLOT DIRECTIONAL AIRFLOW**

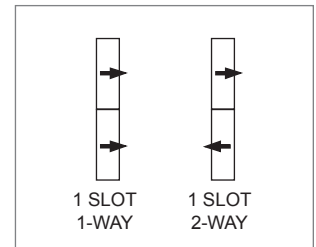

**DFL, 1-SLOT VT ADJUSTMENT 1**

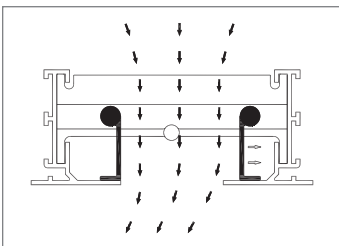

**DFL, 1-SLOT VT ADJUSTMENT 2**

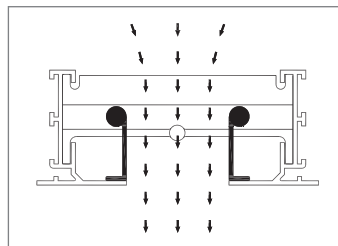

**DFL, 1-SLOT VT ADJUSTMENT 3**

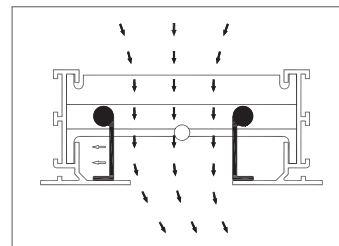

LINEAR SLOT DIFFUSERS

DESIGN FLO

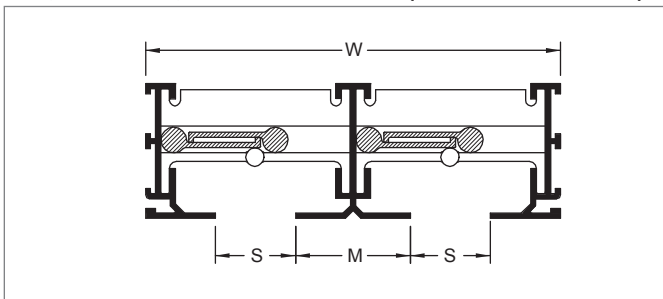
**DFL Frame Styles: 2 Slot**
**DFL, 2NV-SLOT, NARROW REVEAL (FRAME AA SHOWN)**

NOTE: Available frame styles are AA, BB, CC, AC, and FF.

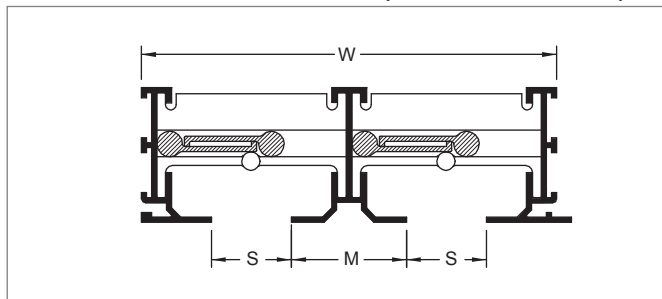
**DFL, 2WV-SLOT, WIDE REVEAL (FRAME AC SHOWN)**

NOTE: Available frame styles are AA, CC, AC, & FF.

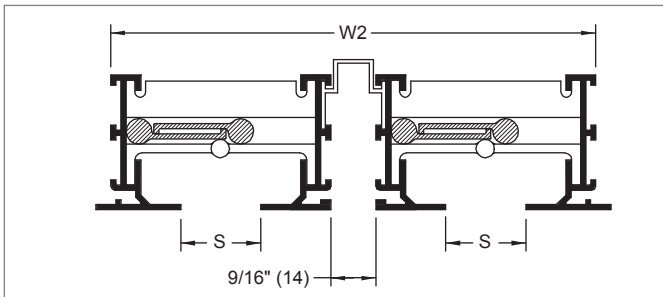
**DFL, 2AB-SLOT, NO REVEAL (FRAME CC SHOWN)**

NOTE: Available frame styles are AA, CC, & AC.

**DFL, FRAME DIMENSIONAL DETAIL**

Slot Width	Width	Stack Width	
		W	W2
S	M		
1"	1 7/16" (37)	5 3/16" (132)	6 1/16" (154)
1.5"	1 15/16" (49)	7 3/16" (183)	8 1/16" (205)
2"	2 7/16" (62)	9 3/16" (233)	10 1/16" (256)
2.5"	2 15/16" (75)	11 3/16" (284)	12 1/16" (306)
3"	3 7/16" (87)	13 3/16" (335)	14 1/16" (357)

NOTE: Dimensions in parentheses are mm.

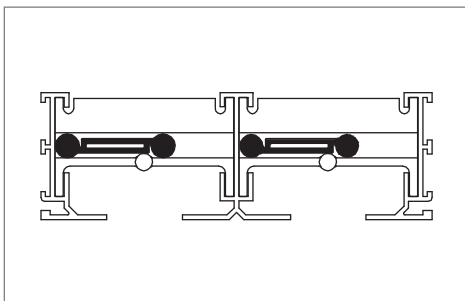
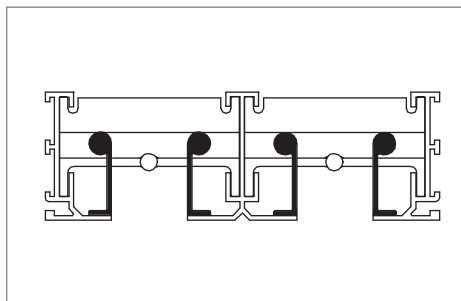
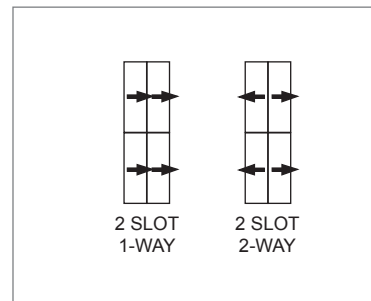
**DFL Pattern Controllers: 2 Slot**
**DFL, 2-SLOT HT PATTERN CONTROLLERS**

**DFL, 2-SLOT VT PATTERN CONTROLLERS**

**DFL, 2-SLOT DIRECTIONAL AIRFLOW**

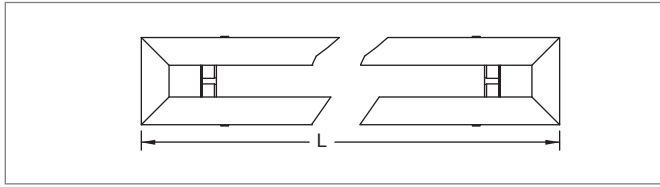
**DFL End Borders**

**DFL, END BORDER 01**



**MITERED / MITERED**

Unit Length = Ordered Length (L)  
Used with Frame AA, CC, and FF  
1 Slot Only

Frame	Stack Size
AA	(L)
CC	L - 3/8" (10)
FF	L - 1" (25)

**DFL, END BORDER 02**

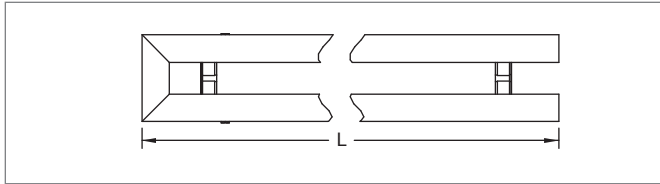

**MITERED / BUTT**

Unit Length = Ordered Length (L)  
Used with Frame AA, CC, and FF  
1 Slot Only

Frame	Stack Size
AA	(L)
CC	L - 3/16" (5)
FF	L - 1/2" (13)

**DFL, END BORDER 03**

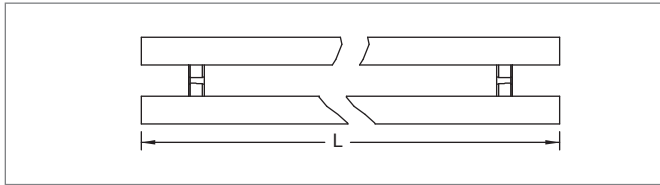

**BUTT / BUTT**

Unit Length = Ordered Length (L)  
Used with All Frames and Slots

**DFL, END BORDER 04**

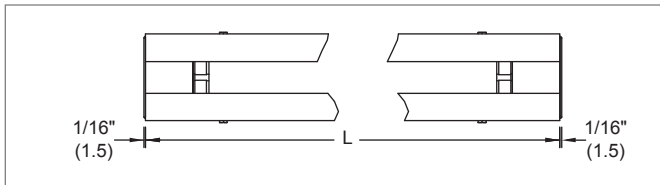

**END PLATE / END PLATE**

Unit Length = Ordered Length (L) + 1/8" (3)  
Used with All Frames and Slots

**DFL, END BORDER 05**

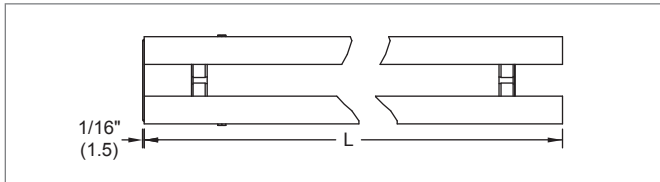

**END PLATE / BUTT**

Unit Length = Ordered Length (L) + 1/16" (1.5)  
Used with All Frames and Slots

**DFL, END BORDER 06**

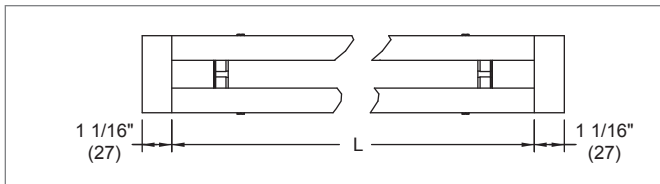

**END CAP / END CAP**

Unit Length = Ordered Length (L) + 2 1/8" (54)  
Used with All Frames and Slots, Except AD and BB

*NOTE: Vertical leg of end cap adds 3/16" (5) to each end of the stack head in the "L" dimension.*

**DFL, END BORDER 07**

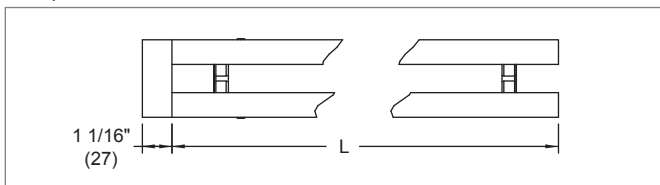

**END CAP / BUTT**

Unit Length = Ordered Length (L) + 1 1/16" (27)  
Used with All Frames and Slots, Except AD and BB

*NOTE: Vertical leg of end cap adds 3/16" (5) to each end of the stack head in the "L" dimension.*

NOTE: Dimensions in parentheses are mm.

LINEAR SLOT DIFFUSERS

DESIGN FLO

## DFL Accessories: Hard Ceiling Mounting Brackets

There are four ceiling clips (H1 - H4), three wall clips (W1 - W3), one suspension clip (US), and one T-Bar attachment clip (SS). SS and US clips can be used with all frames, except for Frame BB.

### USE THE CLIP WITH FRAMES AS FOLLOWS:

**H1:** Used with Frame Type C, F, or B

**H2:** Used with Frame Type A or C

**H3:** Used with Frame BB or the A side of Frame AD. You may have an H3 clip with a Frame AA if the pattern is 'VT'.

**H4:** Used with Frame Type D only

**W1:** Used with Frame Type C only

**W2:** Used with Frame Type A, C, D, or F

**W3:** Used with Frame Type A or D and cannot be used with the optional plenum.

**CF:** Used with Frame Type F only and must be used with concealed mount DFP.

### DFL, H1 HARD CEILING BRACKET

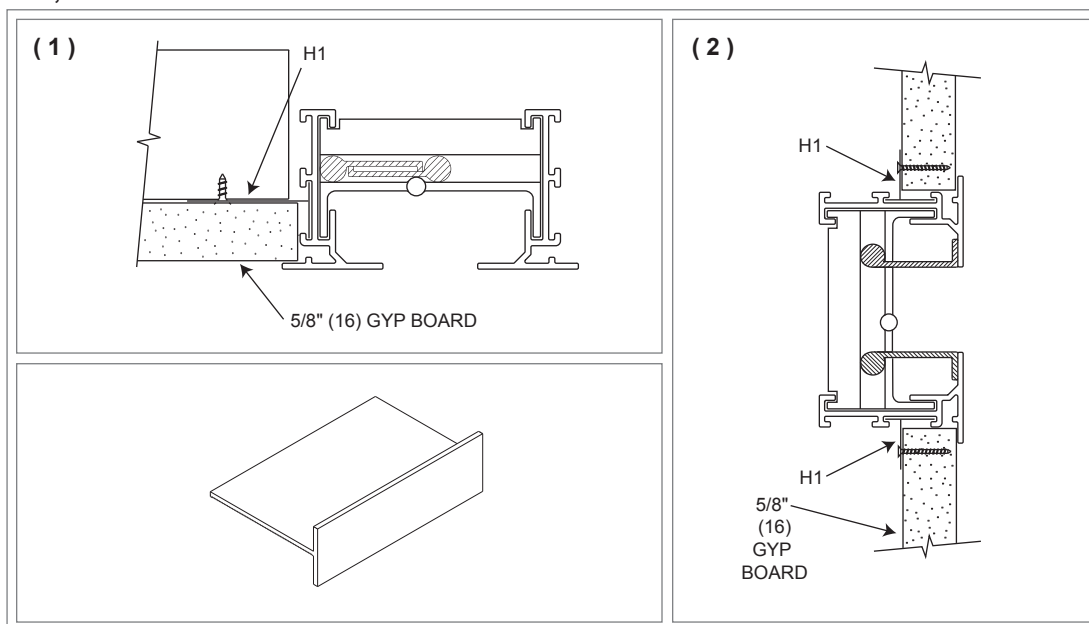

#### NOTES:

(1) H1 Hard Ceiling Brackets are used to mount Frame Type C, F, or B.

(2) H1 Hard Ceiling Brackets shown, used to mount Frame Type C or F in sidewall application.

### DFL, H2 HARD CEILING BRACKET

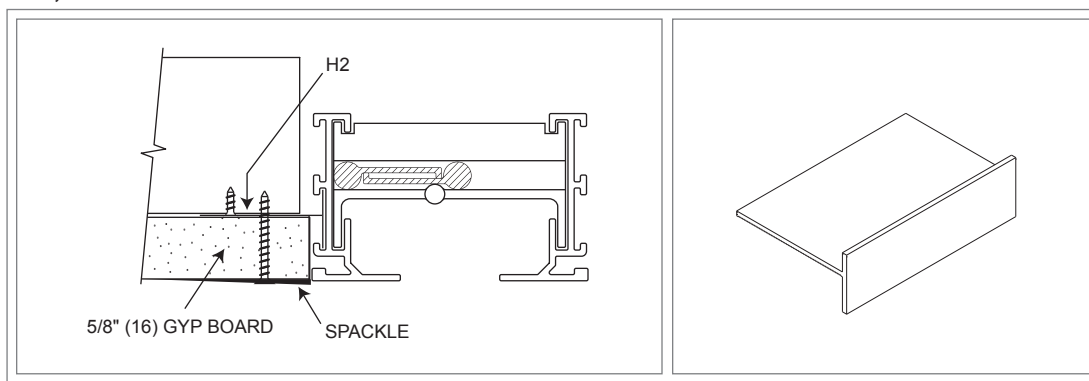

NOTES: H2 Hard Ceiling Brackets are used to mount Frame Type A or C. Best used with Frame Type A.

**DFL Accessories: Hard Ceiling Mounting Brackets**

**DFL, H3 HARD CEILING BRACKET**

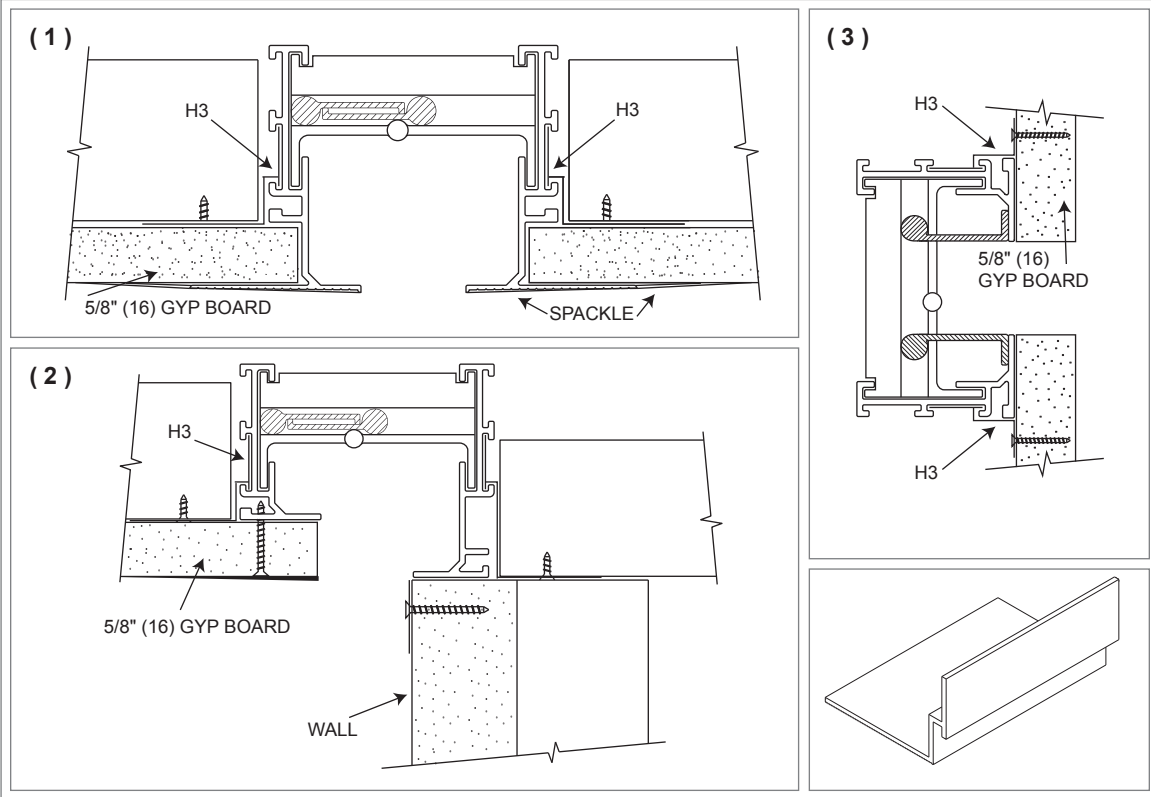

**NOTES:**

- (1) H3 Hard Ceiling Brackets are used to mount Frame BB (2 1/2" and 3").
- (2) H3 Hard Ceiling Brackets are used to mount Frame Type A in Frame AD.
- (3) H3 Hard Ceiling Brackets are used to mount Frame Type A in sidewall VT application.

**DFL, H4 HARD CEILING BRACKET**

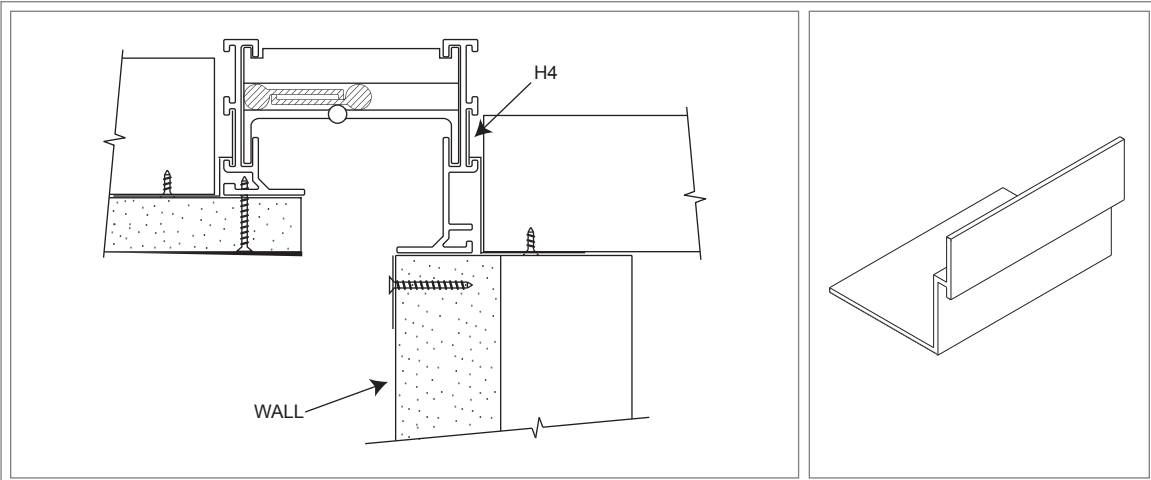

**NOTE:** H4 Hard Ceiling Brackets are used to mount Frame Type D in Frame AD.

LINEAR SLOT DIFFUSERS

DESIGN FLO

**DFL Accessories: Wall Mounting Brackets**

**DFL, W1 WALL BRACKET**

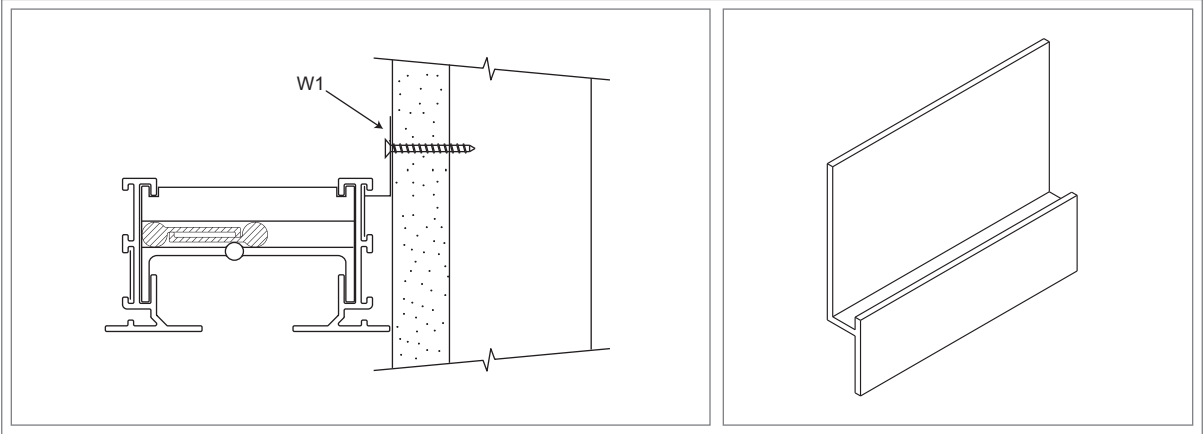

NOTE: W1 Wall Bracket is used to flush mount Frame Type C to a wall.

**DFL, W2 WALL BRACKET**

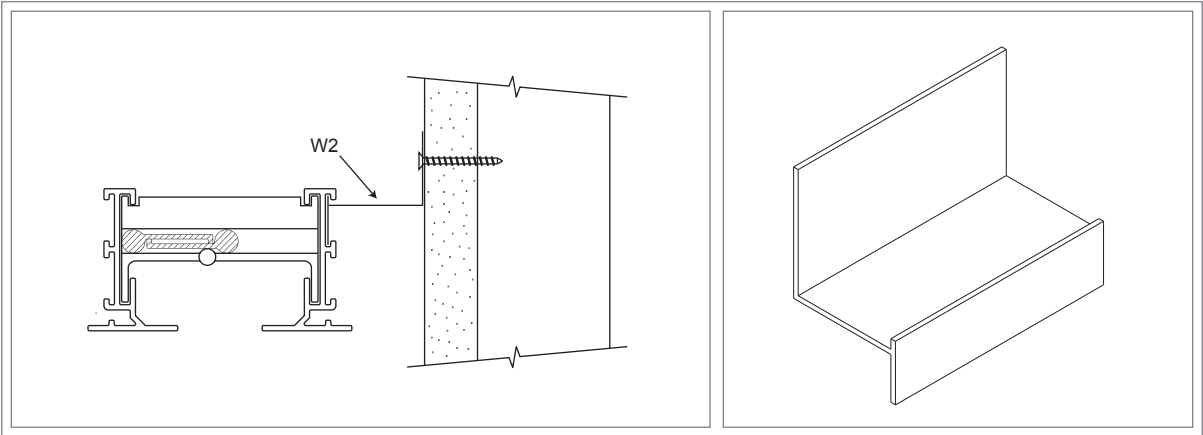

NOTE: W2 Wall Bracket is used to mount Frame Type A, C, D, or F to a wall and create a reveal effect.

**DFL, W3 WALL BRACKET**

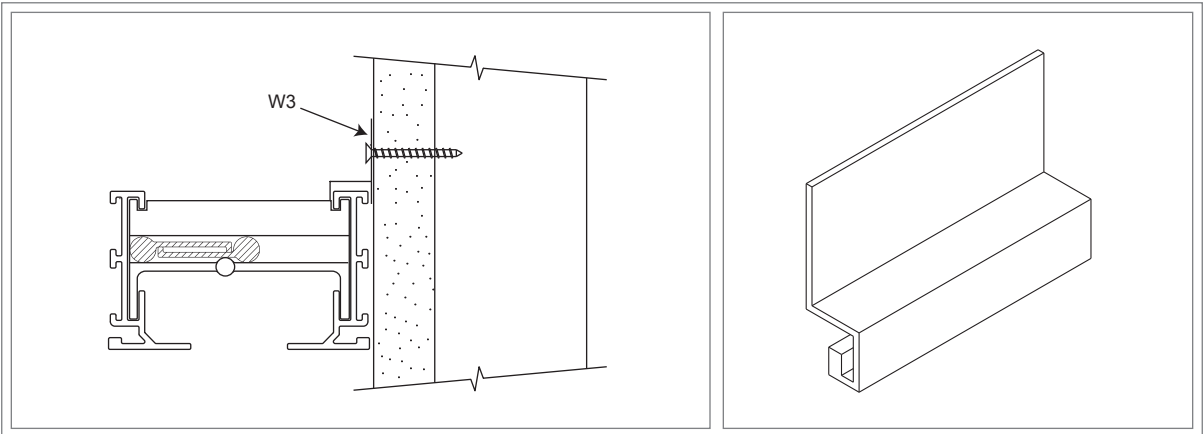

NOTE: W3 Wall Bracket is used to mount Frame Type A or D to a wall.



**DFL Accessories: Support & Hanger Mounting Brackets**

**DFL, US UPPER SUPPORT HANGER**

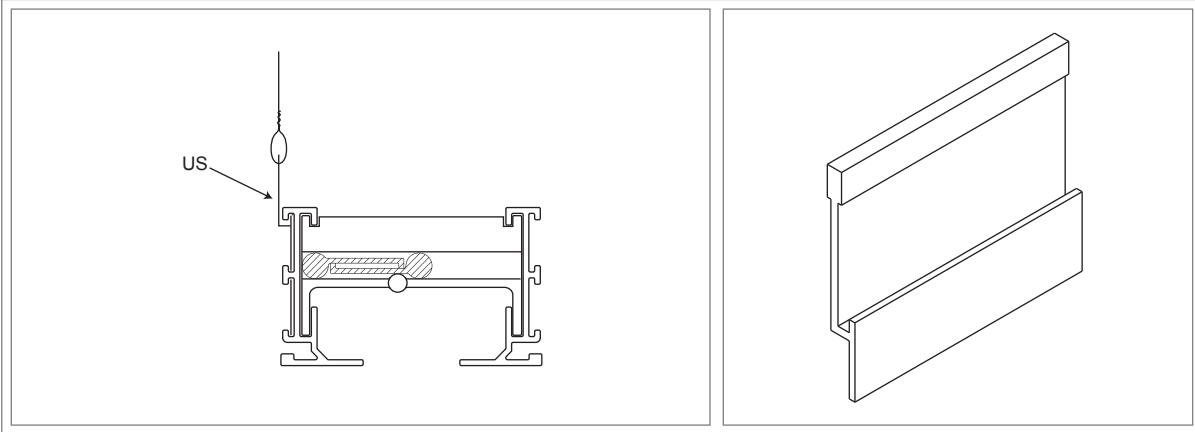

NOTE: US Upper Support Hanger is used to support one side of the DFL unit from the ceiling structure.

**DFL, SS SPLINE SUPPORT BRACKET (AS SUPPLIED)**

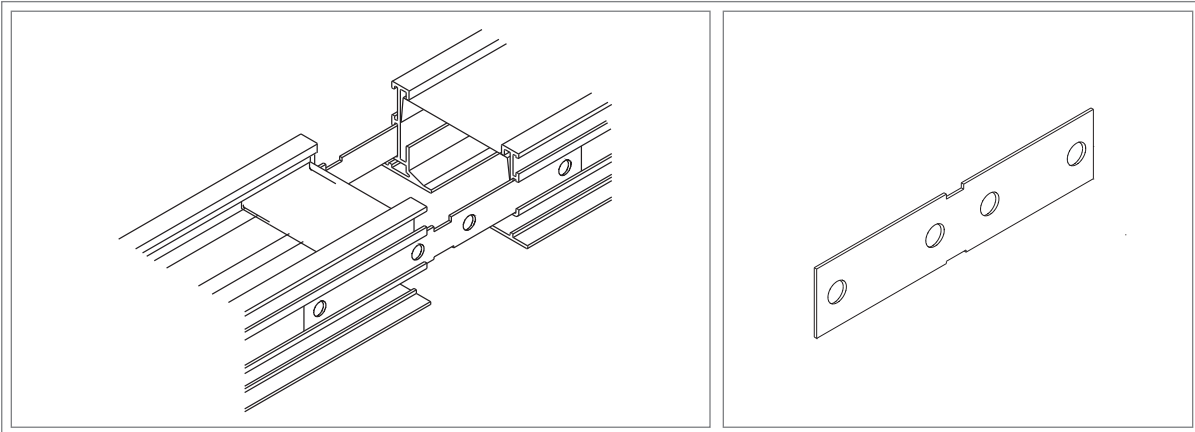

NOTE: SS Spline Support Bracket is used to join multiple sections of DFL into a continuous lot.

**DFL, SS SPLINE SUPPORT BRACKET (FIELD SHAPED)**

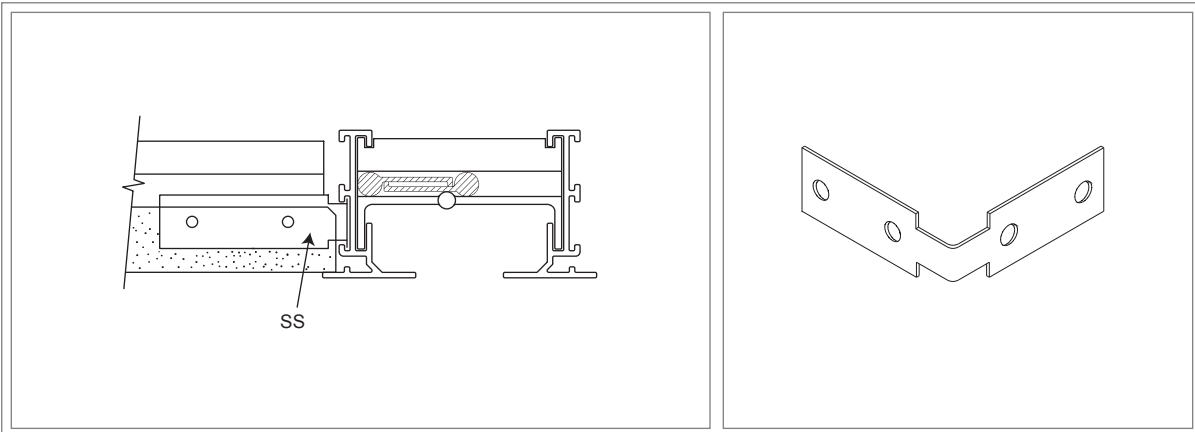

NOTE: SS Spline Support Bracket is used to couple ceiling "T" with DFL unit.

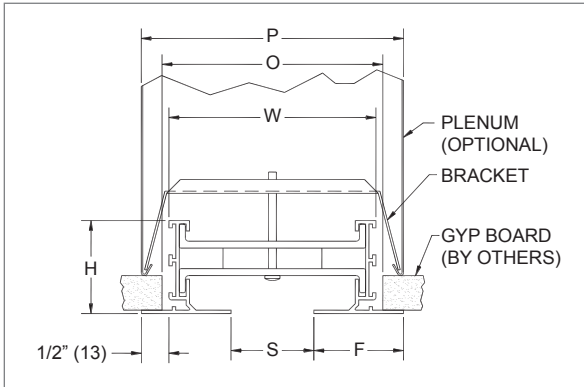
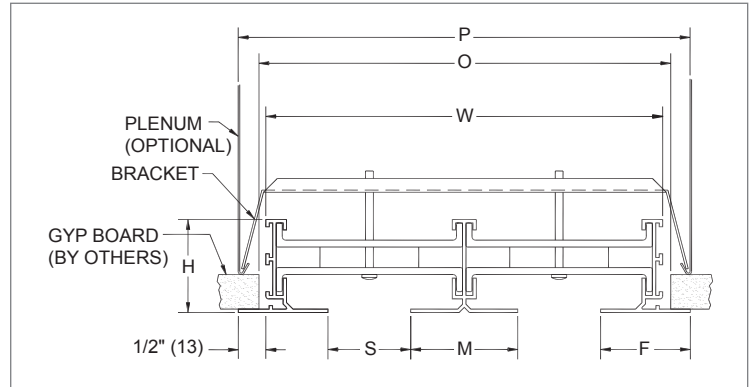
**DFL Concealed Mounting & Plenum (DFP)**
**DFL, CONCEALED MOUNT  
FRAME FF, 1-SLOT**

**DFL, CONCEALED MOUNT  
FRAME FF, 2NV-SLOT (2WV-SLOT OPTIONAL)**

**DFL, CONCEALED MOUNT DIMENSIONAL DETAILS**

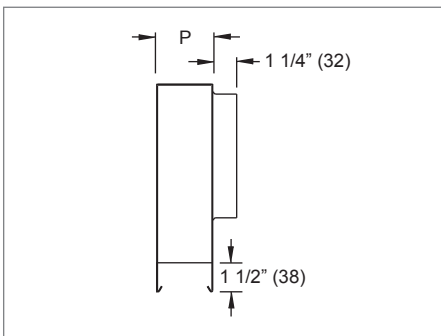
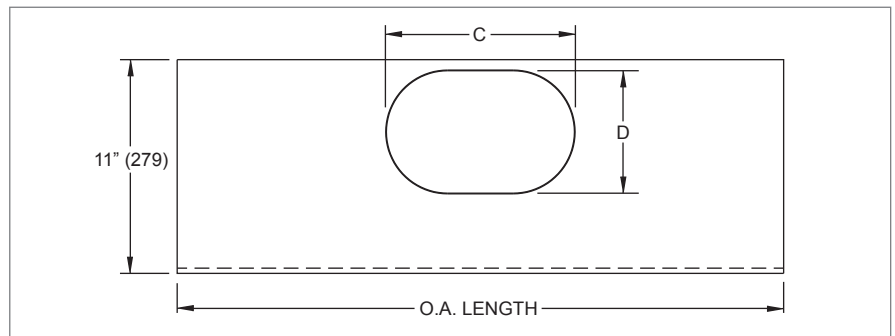
Model	Slot	Frame	Height	1-Slot			2-Slot			
				Stack Width	Ceiling Opening	Plenum	Stack Width	Ceiling Opening	Plenum	Frame
				S	F	H	W	O	P	W
DFL10	1" (25)	1 3/8" (35)	1 11/16" (43)	2 3/4" (70)	3" (76)	3 3/4" (95)	5 3/16" (132)	5 1/2" (140)	6 3/16" (157)	1 7/16" (37)
DFL15	1 1/2" (38)	1 5/8" (41)	1 11/16" (43)	3 3/4" (95)	4" (102)	4 3/4" (121)	7 3/16" (183)	7 1/2" (191)	8 3/16" (208)	1 15/16" (49)
DFL20	2" (51)	1 7/8" (48)	1 11/16" (43)	4 3/4" (121)	5" (127)	5 3/4" (146)	9 3/16" (233)	9 1/2" (241)	10 3/16" (259)	2 7/16" (62)
DFL25	2 1/2" (64)	2 1/8" (54)	2 5/16" (59)	5 3/4" (146)	6" (152)	6 3/4" (171)	11 3/16" (284)	11 1/2" (292)	12 3/16" (310)	2 15/16" (75)
DFL30	3" (76)	2 3/8" (60)	2 5/16" (59)	6 3/4" (171)	7" (178)	7 3/4" (197)	13 3/16" (335)	13 1/2" (343)	14 3/16" (360)	3 7/16" (87)

NOTES: Dimensions in parentheses are mm. Standard HT Pattern Controller. Optional VT Pattern Controller available.

**PLENUM (DFP),  
CONCEALED MOUNT SIDE VIEW**

**PLENUM (DFP),  
CONCEALED MOUNT FACE VIEW**

**PLENUM (DFP), CONCEALED MOUNT DIMENSIONAL DETAILS**

Model	Width (P)		Nominal Length	O. A. Length
	Slot Qty			
	1	2NV / 2WV		
DFP10	3 3/4" (95)	6 3/16" (157)	24" (610)	24" (610)
DFP15	4 3/4" (121)	8 3/16" (208)	36" (914)	36" (914)
DFP20	5 3/4" (146)	10 3/16" (259)	48" (1219)	48" (1219)
DFP25	6 3/4" (171)	12 3/16" (310)	60" (1524)	60" (1524)
DFP30	7 3/4" (197)	14 3/16" (360)		

**PLENUM (DFP), CONCEALED  
MOUNT AVAILABLE INLET SIZES**

Inlet Size	C	D
6" Oval	6 1/4" (159)	5 1/4" (133)
8" Oval	9 3/8" (238)	5 1/4" (133)
10" Oval	12 1/2" (318)	5 1/4" (133)
12" Oval	14 1/8" (359)	7 7/8" (200)

NOTES: Dimensions in parentheses are mm. End caps are not insulated. Quadrant damper adds 6" (152) to inlet depth. Plenum is Mill finish galvanized steel. Insulation is 1/4", 2 lb. density fiberglass.

**DFL Accessories: Plenum (DFP), Return Hood (DFRH), & Blank-off (DFBO)**

**PLENUM (DFP), FACE & SIDE VIEW**

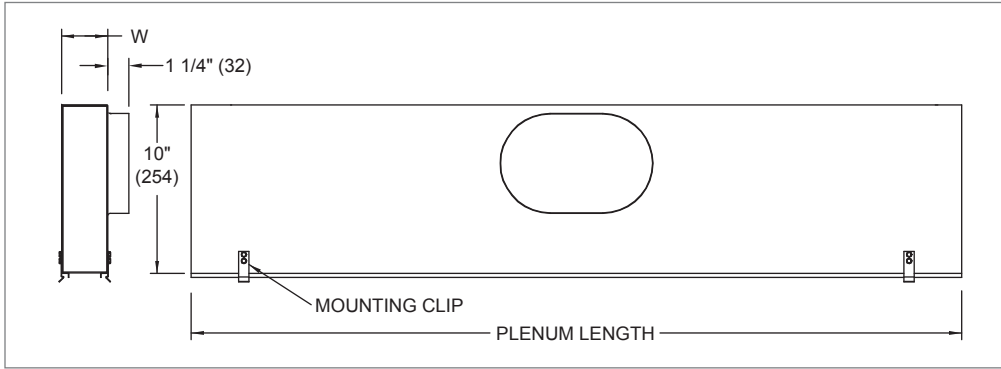

**PLENUM (DFP), AVAILABLE SIZES**

Slot Width	Width			Nominal Length	Standard Available Inlet Sizes	Plenum Length
	Slot Quantity					
	1	2NV / 2NW	2AB		Oval	
<b>1" (25)</b>	2 3/4" (70)	5 3/16" (132)	6 1/16" (154)	24" (610) 36" (914) 48" (1219) 60" (1524)	6" (152)	21 3/4" (552)
<b>1 1/2" (38)</b>	3 3/4" (95)	7 3/16" (183)	8 1/16" (205)		8" (203)	33 3/4" (857)
<b>2" (51)</b>	4 3/4" (121)	9 3/16" (233)	10 1/16" (256)		10" (254)	45 3/4" (1162)
<b>2 1/2" (64)</b>	5 3/4" (146)	11 3/16" (284)	12 1/16" (306)		12" (305)	57 3/4" (1467)
<b>3" (76)</b>	6 3/4" (171)	13 3/16" (335)	14 1/16" (357)			

NOTES: Dimensions in parentheses are mm. End caps are not insulated. Quadrant damper adds 6" (152) to inlet depth. Plenum is galvanized steel, Mill finish. Insulation is 1/4" (6) 2 lb. single density.

LINEAR SLOT DIFFUSERS

**STANDARD RETURN HOOD (DFRH)**

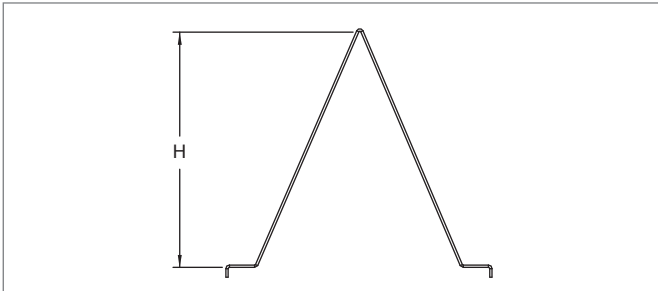

**BLANK-OFF (DFBO)**

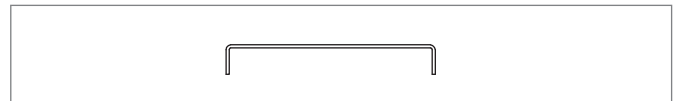

**RETURN HOOD (DFRH) AVAILABLE SIZES**

Slot Quantity	Slot Width	Height (H)
1	1" (25)	3 3/8" (86)
	1 1/2" (38)	3 3/8" (86)
	2" (51)	3 3/8" (86)
	2 1/2" (64)	3 3/8" (86)
	3" (76)	3 3/8" (86)
2	1" (25)	2 1/8" (54)
	1 1/2" (38)	3 1/8" (79)
	2" (51)	4 1/8" (105)
	2 1/2" (64)	5 1/8" (130)
	3" (76)	6 1/8" (156)

**INSULATED RETURN HOOD (DFRH)**

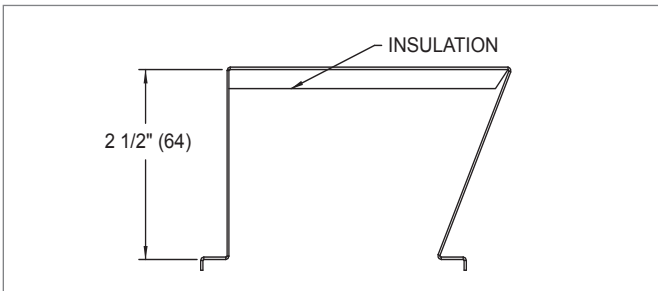

NOTES: Dimensions in parentheses are mm. Pieces ship 48" (1219) long, field cut. Material is galvanized steel, painted black. Returns are 51% perforated. Insulation is 1/4" (6) 2 lb. single density.

DESIGN FLO

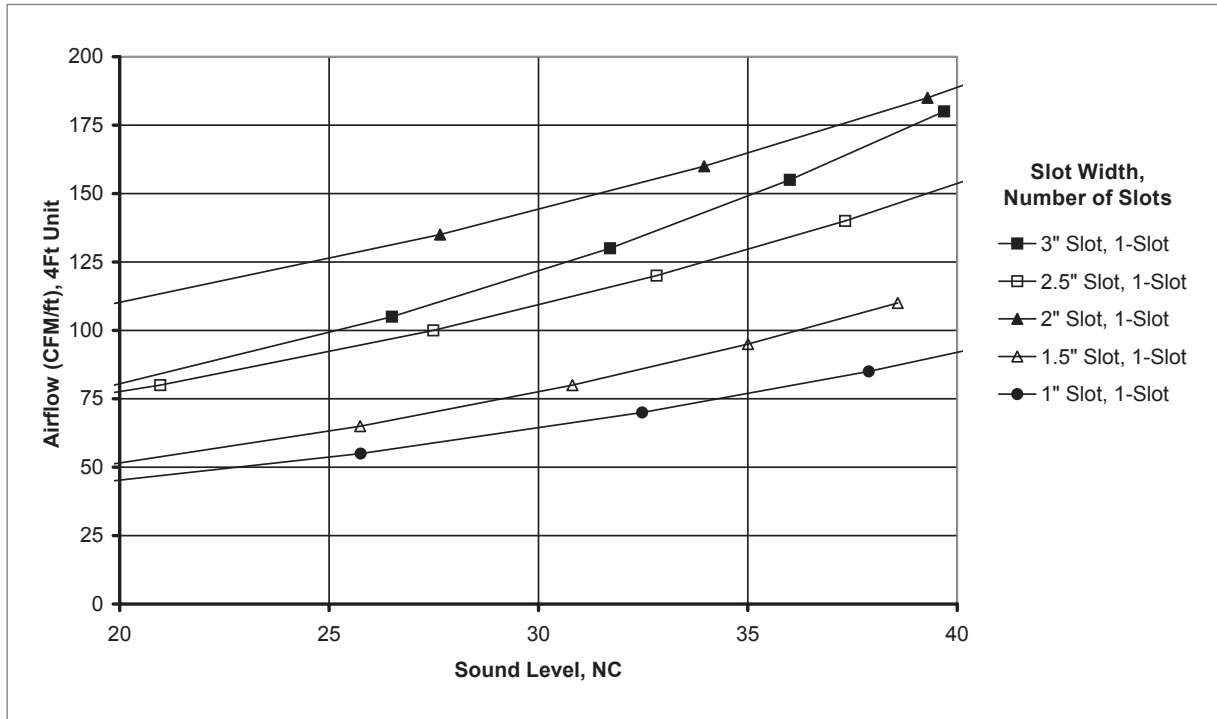
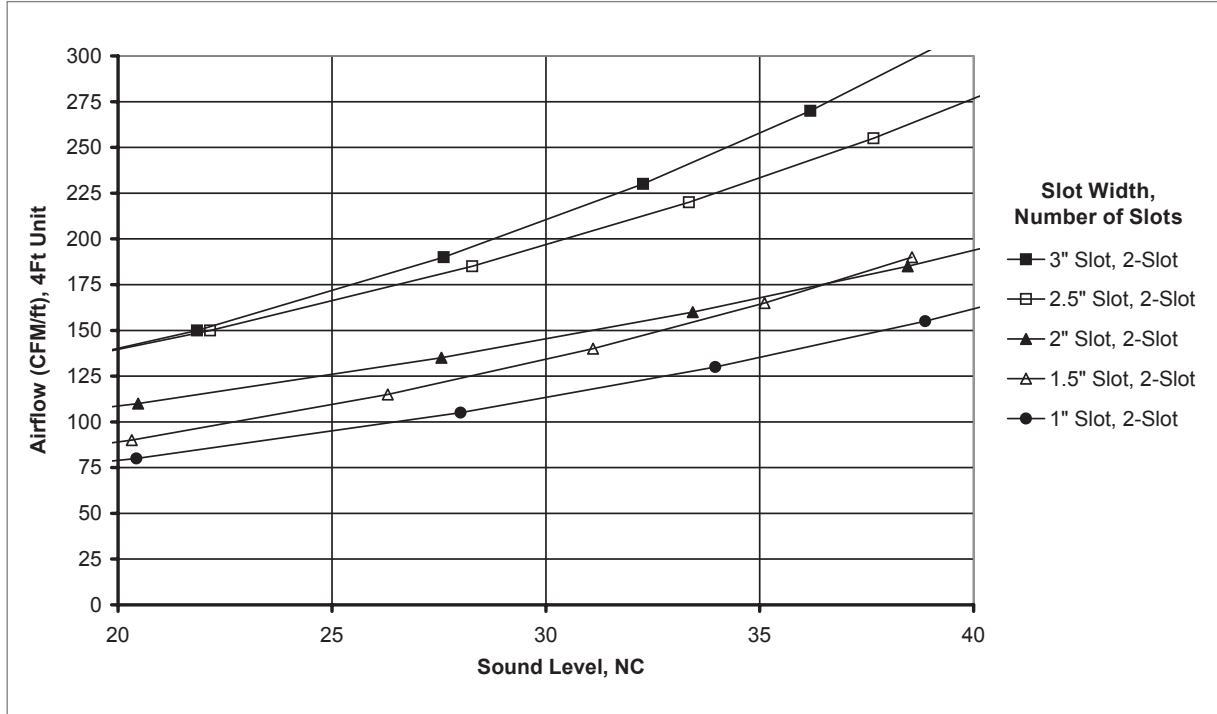
**DFL Reference Charts: Horizontal Throw**
**AIRFLOW VS. NC LEVEL: DFL, 1-SLOT**

**AIRFLOW VS. NC LEVEL: DFL, 2-SLOT**

**DFL Performance Data: Horizontal Throw**

IP/METRIC DATA: DFL, CONTINUOUS SLOT (HT BLADES)

		IP Data					NC	Metric Data				Octave Band, dB						
		Air Flow	Press Ps	1 - Way Throw	2 - Way Throw			Air Flow	Press Ps	1 - Way Throw	2 - Way Throw	2	3	4	5	6	7	
		CFM/ft	"WG	ft	ft			L/s/m	Pa	m	m							
1.0" Slot Width	1 Slot	10	0.004	1 - 3 - 8	1 - 2 - 6	-	16	1.0	0.4 - 0.8 - 2.5	0.3 - 0.6 - 1.8	15	-	-	-	-	-		
		25	0.024	7 - 10 - 19	5 - 7 - 14	-	39	6.0	2.1 - 3.1 - 5.8	1.5 - 2.2 - 4.1	30	29	18	-	-	-		
		55	0.117	15 - 20 - 28	11 - 14 - 20	26	85	29.2	4.5 - 6.1 - 8.6	3.2 - 4.3 - 6.1	44	48	39	33	24	14		
		70	0.190	18 - 23 - 32	13 - 16 - 23	32	109	47.3	5.6 - 6.9 - 9.7	4.0 - 4.9 - 6.9	48	54	45	40	31	19		
		85	0.280	20 - 25 - 35	14 - 18 - 25	38	132	69.7	6.2 - 7.6 - 10.7	4.4 - 5.4 - 7.6	51	58	50	46	37	24		
	2 Slots	30	0.009	4 - 8 - 17	3 - 6 - 12	-	47	2.2	1.1 - 2.6 - 5.3	0.8 - 1.8 - 3.7	25	20	-	-	-	-		
		80	0.062	15 - 23 - 34	11 - 16 - 24	20	124	15.4	4.7 - 7.0 - 10.4	3.3 - 5.0 - 7.4	41	43	33	26	17	-		
		105	0.107	20 - 28 - 39	14 - 20 - 28	28	163	26.6	6.1 - 8.4 - 11.9	4.3 - 6.0 - 8.4	46	50	40	34	25	16		
		130	0.164	25 - 31 - 44	18 - 22 - 31	34	202	40.8	7.6 - 9.4 - 13.3	5.4 - 6.6 - 9.4	49	55	46	41	32	21		
		155	0.233	28 - 34 - 48	19 - 24 - 34	39	241	58.0	8.4 - 10.2 - 14.5	5.9 - 7.2 - 10.2	52	59	51	46	37	25		
1.5" Slot Width	1 Slot	20	0.008	3 - 5 - 11	2 - 4 - 8	-	31	2.1	0.9 - 1.7 - 3.3	0.7 - 1.2 - 2.4	26	23	-	-	-	-		
		50	0.053	9 - 14 - 26	6 - 10 - 19	19	78	13.1	2.8 - 4.2 - 8.0	2.0 - 2.9 - 5.9	42	42	33	27	19	-		
		65	0.089	12 - 18 - 30	8 - 13 - 25	26	101	22.2	3.6 - 5.4 - 9.1	2.5 - 3.8 - 7.6	47	48	39	34	28	19		
		95	0.191	17 - 26 - 36	12 - 18 - 36	35	147	47.4	5.3 - 7.8 - 11.1	3.7 - 5.6 - 11.1	54	56	49	45	41	31		
		110	0.255	20 - 28 - 39	14 - 21 - 39	39	171	63.6	6.1 - 8.4 - 11.9	4.3 - 6.5 - 11.9	56	59	52	49	46	36		
	2 Slots	40	0.008	4 - 8 - 15	3 - 5 - 11	-	62	2.1	1.3 - 2.4 - 4.7	0.9 - 1.7 - 3.3	29	26	13	-	-	-		
		90	0.043	12 - 17 - 35	8 - 12 - 25	20	140	10.6	3.5 - 5.3 - 10.6	2.5 - 3.7 - 7.5	43	43	33	27	18	-		
		115	0.070	15 - 22 - 40	10 - 16 - 31	26	179	17.4	4.5 - 6.8 - 12.2	3.2 - 4.8 - 9.6	48	48	39	34	27	17		
		165	0.144	21 - 32 - 48	15 - 23 - 45	35	256	35.8	6.5 - 9.7 - 14.6	4.6 - 6.9 - 13.7	54	56	48	44	39	30		
		190	0.191	24 - 36 - 51	17 - 26 - 51	39	295	47.4	7.4 - 11.1 - 15.6	5.3 - 7.9 - 15.6	57	59	52	48	44	34		
2.0" Slot Width	1 Slot	30	0.015	3 - 8 - 18	2 - 5 - 13	-	47	3.8	1.0 - 2.3 - 5.5	0.7 - 1.7 - 3.9	25	23	14	-	-	-		
		60	0.062	12 - 18 - 26	9 - 13 - 18	20	93	15.4	3.7 - 5.5 - 7.9	2.6 - 3.9 - 5.6	43	43	34	29	24	11		
		75	0.096	15 - 21 - 29	11 - 15 - 21	28	116	24.0	4.6 - 6.2 - 8.8	3.2 - 4.4 - 6.2	49	49	41	36	32	20		
		90	0.139	18 - 23 - 32	13 - 16 - 23	34	140	34.6	5.5 - 6.8 - 9.7	3.9 - 4.8 - 6.8	54	55	46	42	39	27		
		105	0.189	20 - 24 - 34	14 - 17 - 24	39	163	47.0	6.0 - 7.4 - 10.5	4.3 - 5.2 - 7.4	58	59	50	47	44	33		
	2 Slots	60	0.015	5 - 11 - 26	3 - 8 - 18	-	93	3.8	1.5 - 3.3 - 7.8	1.0 - 2.3 - 5.5	28	26	17	-	-	-		
		110	0.052	16 - 23 - 35	11 - 17 - 25	20	171	12.9	4.7 - 7.1 - 10.7	3.4 - 5.0 - 7.6	44	43	34	29	23	-		
		135	0.078	19 - 28 - 39	14 - 19 - 28	28	210	19.4	5.8 - 8.4 - 11.9	4.1 - 5.9 - 8.4	49	49	40	36	31	18		
		160	0.110	23 - 30 - 42	16 - 21 - 30	33	248	27.3	6.9 - 9.1 - 12.9	4.9 - 6.5 - 9.1	54	54	45	42	37	25		
		185	0.147	26 - 32 - 46	19 - 23 - 32	38	287	36.5	8.0 - 9.8 - 13.9	5.6 - 6.9 - 9.8	57	59	50	46	43	31		
2.5" Slot Width	1 Slot	40	0.014	3 - 7 - 14	2 - 5 - 10	-	62	3.5	1.0 - 2.1 - 4.2	0.7 - 1.5 - 3.0	29	26	19	13	-	-		
		80	0.056	9 - 14 - 23	6 - 10 - 19	21	124	14.1	2.8 - 4.2 - 7.0	2.0 - 3.0 - 5.9	44	43	37	33	27	-		
		100	0.088	11 - 17 - 26	8 - 12 - 24	27	155	22.0	3.5 - 5.2 - 7.8	2.5 - 3.7 - 7.4	48	49	42	39	34	19		
		140	0.173	16 - 22 - 30	11 - 17 - 30	37	217	43.1	4.9 - 6.6 - 9.3	3.4 - 5.2 - 9.3	56	57	50	49	46	33		
		160	0.226	18 - 23 - 33	13 - 19 - 33	41	248	56.3	5.6 - 7.0 - 9.9	3.9 - 5.9 - 9.9	58	60	54	53	51	39		
	2 Slots	80	0.014	5 - 10 - 19	3 - 7 - 14	-	124	3.5	1.4 - 3.0 - 5.9	1.0 - 2.1 - 4.2	32	29	22	16	-	-		
		150	0.050	12 - 18 - 32	9 - 14 - 27	22	233	12.4	3.7 - 5.5 - 9.6	2.8 - 4.2 - 8.3	45	45	38	34	28	-		
		185	0.076	15 - 22 - 35	11 - 17 - 34	28	287	18.8	4.6 - 6.8 - 10.7	3.5 - 5.2 - 10.4	50	50	43	40	35	18		
		255	0.143	21 - 29 - 41	16 - 24 - 43	38	396	35.7	6.3 - 8.8 - 12.5	4.9 - 7.3 - 13.1	57	57	51	49	46	32		
		290	0.186	23 - 31 - 44	18 - 27 - 46	41	450	46.2	7.1 - 9.4 - 13.3	5.6 - 8.3 - 14.0	59	61	54	53	50	37		
3.0" Slot Width	1 Slot	30	0.006	2 - 4 - 12	1 - 3 - 9	-	47	1.4	0.5 - 1.1 - 3.7	0.3 - 0.8 - 2.6	24	23	12	-	-	-		
		80	0.041	11 - 16 - 25	9 - 13 - 19	20	124	10.2	3.3 - 5.0 - 7.6	2.6 - 4.0 - 5.7	44	43	34	31	27	19		
		105	0.071	14 - 20 - 29	12 - 15 - 22	27	163	17.6	4.4 - 6.1 - 8.7	3.5 - 4.6 - 6.6	49	48	41	38	35	28		
		155	0.154	20 - 25 - 35	15 - 19 - 26	36	241	38.3	6.1 - 7.5 - 10.6	4.6 - 5.7 - 8.0	58	57	49	47	46	42		
		180	0.208	22 - 26 - 37	17 - 20 - 29	40	279	51.7	6.6 - 8.0 - 11.4	5.0 - 6.1 - 8.7	61	60	53	51	51	48		
	2 Slots	70	0.008	3 - 7 - 20	1 - 3 - 10	-	109	2.0	0.9 - 2.1 - 6.2	0.3 - 0.8 - 3.1	30	29	18	14	-	-		
		150	0.036	14 - 22 - 34	12 - 17 - 26	22	233	9.0	4.4 - 6.6 - 10.4	3.5 - 5.3 - 7.8	46	45	36	32	28	19		
		190	0.058	18 - 27 - 38	16 - 21 - 30	28	295	14.4	5.6 - 8.3 - 11.7	4.8 - 6.4 - 9.1	50	49	41	38	35	28		
		270	0.117	26 - 32 - 46	21 - 26 - 37	36	419	29.1	7.9 - 9.9 - 13.9	6.5 - 7.9 - 11.2	58	57	49	47	45	40		
		310	0.154	28 - 35 - 49	23 - 28 - 40	40	481	38.3	8.6 - 10.6 - 14.9	7.0 - 8.6 - 12.1	61	60	52	50	49	45		

NC Correction for Length					
Length, ft	2	4	6	8	10
Length, m	0.6	1.2	1.8	2.4	3.0
Supply	-2	0	+2	+3	+5
Return	0	+3	+5	+6	+8

Throw Multiplier for Length					
Length, ft	2	4	8	10	12
Length, m	0.6	1.2	2.4	3.0	3.6
Correction	0.7	0	1.5	1.7	1.8

NOTE: See page E1-15 for notes.

LINEAR SLOT DIFFUSERS

DESIGN FLO

**DFL Performance Data: Vertical Throw**
**IP/METRIC DATA: DFL, CONTINUOUS SLOT (VT BLADES)**

		IP Data				NC	Metric Data			Octave Band, dB						
		Air Flow	Press Ps	Perpendicular Throw	Air Flow		Press Ps	Perpendicular Throw	2	3	4	5	6	7		
		CFM/ft	"WG	ft	L/s/m		Pa	m								
1.0" Slot Width	1 Slot	20	0.003	2 - 3 - 6	-	31	0.8	0.5 - 0.9 - 1.8	-	11	-	-	-	-		
		80	0.054	8 - 12 - 19	19	124	13.3	2.5 - 3.7 - 5.7	41	42	34	30	22	13		
		110	0.101	11 - 16 - 22	27	171	25.2	3.4 - 4.7 - 6.7	49	49	42	38	31	23		
		140	0.164	14 - 18 - 25	33	217	40.8	4.3 - 5.3 - 7.6	55	54	47	44	38	31		
	200	0.335	17 - 21 - 30	42	310	83.3	5.2 - 6.4 - 9.0	65	62	56	52	49	42			
	2 Slots	50	0.005	4 - 5 - 11	-	78	1.3	1.1 - 1.6 - 3.3	14	19	-	-	-	-		
		150	0.047	11 - 16 - 26	20	233	11.7	3.3 - 4.9 - 7.8	42	43	36	31	23	14		
		200	0.084	14 - 21 - 30	28	310	20.8	4.3 - 6.4 - 9.0	50	50	42	38	32	23		
250		0.131	18 - 23 - 33	34	388	32.5	5.4 - 7.1 - 10.1	56	54	48	44	38	30			
350	0.256	23 - 28 - 39	42	543	63.8	6.9 - 8.4 - 11.9	64	62	56	52	48	41				
1.5" Slot Width	1 Slot	30	0.006	2 - 4 - 7	-	47	1.4	0.7 - 1.1 - 2.3	13	-	-	-	-	-		
		100	0.063	8 - 12 - 21	14	155	15.7	2.5 - 3.8 - 6.4	42	37	31	25	17	-		
		135	0.115	11 - 17 - 24	23	210	28.6	3.4 - 5.1 - 7.4	49	44	39	34	30	22		
		170	0.182	14 - 19 - 27	30	264	45.3	4.3 - 5.9 - 8.3	55	50	45	42	40	33		
	240	0.363	19 - 23 - 33	44	373	90.3	5.7 - 7.0 - 9.9	63	58	54	52	55	51			
	2 Slots	40	0.003	1 - 3 - 7	-	62	0.6	0.4 - 0.9 - 2.1	-	-	-	-	-	-		
		160	0.040	9 - 14 - 27	11	248	10.0	2.8 - 4.3 - 8.1	39	34	28	21	11	-		
		220	0.076	13 - 19 - 31	20	342	19.0	3.9 - 5.8 - 9.5	47	42	37	31	24	14		
280		0.123	16 - 24 - 35	27	435	30.7	5.0 - 7.4 - 10.7	53	48	43	38	35	27			
400	0.252	23 - 30 - 42	39	621	62.7	7.1 - 9.0 - 12.8	62	57	52	50	50	45				
2.0" Slot Width	1 Slot	20	0.002	1 - 1 - 4	-	31	0.4	0.2 - 0.4 - 1.3	30	25	-	-	-	-		
		100	0.044	7 - 11 - 21	20	155	10.9	2.2 - 3.3 - 6.4	45	43	32	15	-	-		
		140	0.086	10 - 15 - 25	24	217	21.3	3.0 - 4.6 - 7.6	48	47	39	25	17	-		
		180	0.141	13 - 19 - 28	28	279	35.2	3.9 - 5.9 - 8.6	51	49	44	33	27	16		
	260	0.295	19 - 24 - 34	37	404	73.5	5.6 - 7.3 - 10.3	54	54	52	44	43	32			
	2 Slots	40	0.002	1 - 2 - 6	-	62	0.4	0.3 - 0.6 - 1.8	33	28	-	-	-	-		
		180	0.035	9 - 14 - 27	22	279	8.8	2.8 - 4.1 - 8.3	47	45	33	15	-	-		
		250	0.068	13 - 19 - 33	26	388	17.0	3.8 - 5.8 - 10.1	50	48	39	25	15	-		
320		0.112	16 - 24 - 38	30	497	27.8	4.9 - 7.4 - 11.4	53	51	44	32	25	13			
460	0.231	23 - 32 - 45	37	714	57.5	7.1 - 9.7 - 13.7	56	55	52	44	40	30				
2.5" Slot Width	1 Slot	20	0.001	0 - 1 - 4	-	31	0.3	0.1 - 0.3 - 1.2	-	-	-	-	-	-		
		120	0.049	8 - 11 - 23	11	186	12.2	2.3 - 3.5 - 7.0	38	34	28	13	-	-		
		170	0.098	11 - 16 - 27	19	264	24.5	3.3 - 4.9 - 8.3	44	41	35	24	21	-		
		220	0.165	14 - 21 - 31	25	342	41.0	4.3 - 6.4 - 9.5	49	46	40	32	30	19		
	320	0.348	20 - 27 - 38	33	497	86.7	6.2 - 8.1 - 11.4	55	54	48	44	43	38			
	2 Slots	40	0.001	1 - 1 - 5	-	62	0.3	0.2 - 0.4 - 1.6	-	-	-	-	-	-		
		220	0.041	10 - 15 - 30	13	342	10.2	3.0 - 4.5 - 9.1	40	35	29	13	-	-		
		310	0.082	14 - 21 - 37	20	481	20.3	4.3 - 6.4 - 11.2	46	42	36	24	21	-		
400		0.136	18 - 27 - 42	26	621	33.9	5.5 - 8.2 - 12.8	50	47	41	32	30	17			
580	0.286	26 - 36 - 51	34	900	71.2	8.0 - 10.9 - 15.4	56	55	49	44	43	36				
3.0" Slot Width	1 Slot	20	0.001	0 - 1 - 3	-	31	0.3	0.1 - 0.2 - 0.9	-	-	-	-	-	-		
		140	0.051	8 - 12 - 24	-	217	12.6	2.5 - 3.7 - 7.4	40	31	22	14	-	-		
		200	0.104	12 - 17 - 30	16	310	25.8	3.5 - 5.3 - 9.0	47	39	31	24	21	-		
		260	0.175	15 - 23 - 34	23	404	43.6	4.6 - 6.9 - 10.3	51	45	38	31	29	19		
	380	0.374	22 - 29 - 41	33	590	93.1	6.7 - 8.8 - 12.4	59	54	47	41	41	34			
	2 Slots	50	0.002	1 - 2 - 6	-	78	0.4	0.2 - 0.5 - 1.9	-	-	-	-	-	-		
		250	0.040	10 - 15 - 31	-	388	10.1	3.1 - 4.7 - 9.4	41	32	23	14	-	-		
		350	0.079	14 - 22 - 39	16	543	19.8	4.4 - 6.6 - 11.9	47	39	31	23	20	-		
450		0.131	19 - 28 - 45	23	699	32.7	5.6 - 8.5 - 13.5	52	45	37	30	28	16			
650	0.274	27 - 38 - 54	33	1009	68.1	8.1 - 11.5 - 16.3	59	54	46	40	39	31				

NOTES: Throw values are given for terminal velocities of 150, 100, and 50 FPM (0.75, 0.50, and 0.25 m/s). NC values are based on octave band 2 - 7 sound power levels minus a room absorption of 10dB, re 10<sup>-12</sup> Watts. Dash in space denotes a NC or dB value of less than 10. Data was obtained from tests conducted in accordance with ANSI/ASHRAE Standard 70, ISO Standard 5219, and ISO Standard 3741. 2-Way, 1-Slot throw is split throw. Refer to page E1-4 and E1-5 for directional airflow descriptions. Pressures are for diffuser section only. Plenums will add to sound level and pressure drop. Keep inlet velocities below 800 FPM to reduce plenum generated sound level and pressure drop. See correction factors on page E1-14. See selection software for performance data not shown, including octave band data.

**DFL For Lay-In T-Bar (DFB) & Narrow-T (DFNT) Applications**

DFB/DFNT, SIDE VIEW

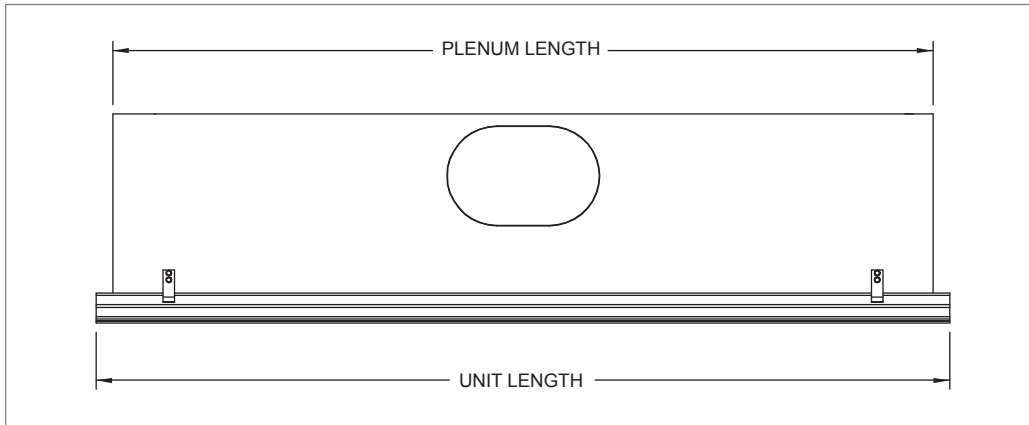

DFB/DFNT, END VIEW & DETAIL

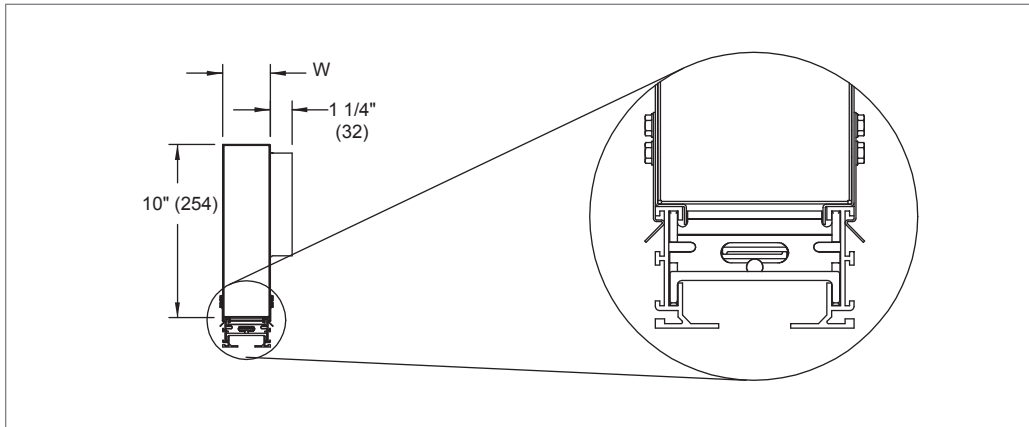

DFB/DFNT, AVAILABLE SIZES

Slot Width	Width (W)			Nominal Length	Standard Available Inlet Sizes	Plenum Length		Unit Length		
	Slot Quantity					Oval	DFB	DFNT	DFB	DFNT
	1	2NV/2NW	2AB							
1" (25)	2 3/4" (70)	5 3/16" (132)	6 1/16" (154)	24" (610)	6" (152) 8" (203) 10" (254) 12" (305)	21 3/4" (552)	213/8" (543)	23 5/8" (600)	23 7/16" (595)	
1 1/2" (38)	3 3/4" (95)	7 3/16" (183)	8 1/16" (205)	48" (1219)		45 3/4" (1162)	45 3/8" (1153)	47 5/8" (1210)	47 7/16" (1205)	
2" (51)	4 3/4" (121)	9 3/16" (233)	10 1/16" (256)	60" (1524)		57 3/4" (1467)	-	59 5/8" (1514)	-	

NOTES: Dimensions in parentheses are mm. End caps are not insulated. Quadrant damper adds 6" to inlet depth. Plenum is galvanized steel, Mill finish. Insulation is 1/4" (6) 2 lb. single density.

LINEAR SLOT DIFFUSERS

DESIGN FLO

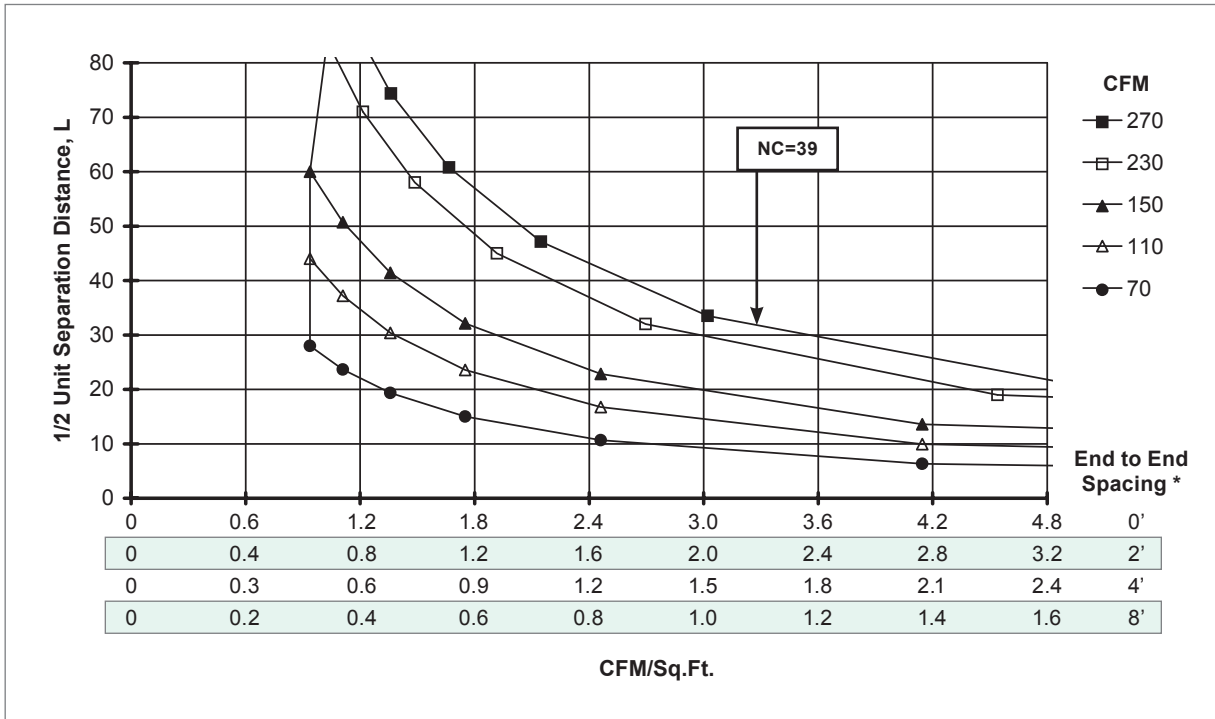
**DFL Reference Charts: For Lay-In T-Bar (DFB) & Narrow-T (DFNT), Horizontal Throw –**
**DIFFUSER SPACING FOR 80% ADPI: DFB/DFNT, 4 FT. LENGTH, 1" SLOT WIDTH, 1-SLOT, 1-WAY, 8" INLET PLENUM**

LINEAR SLOT DIFFUSERS

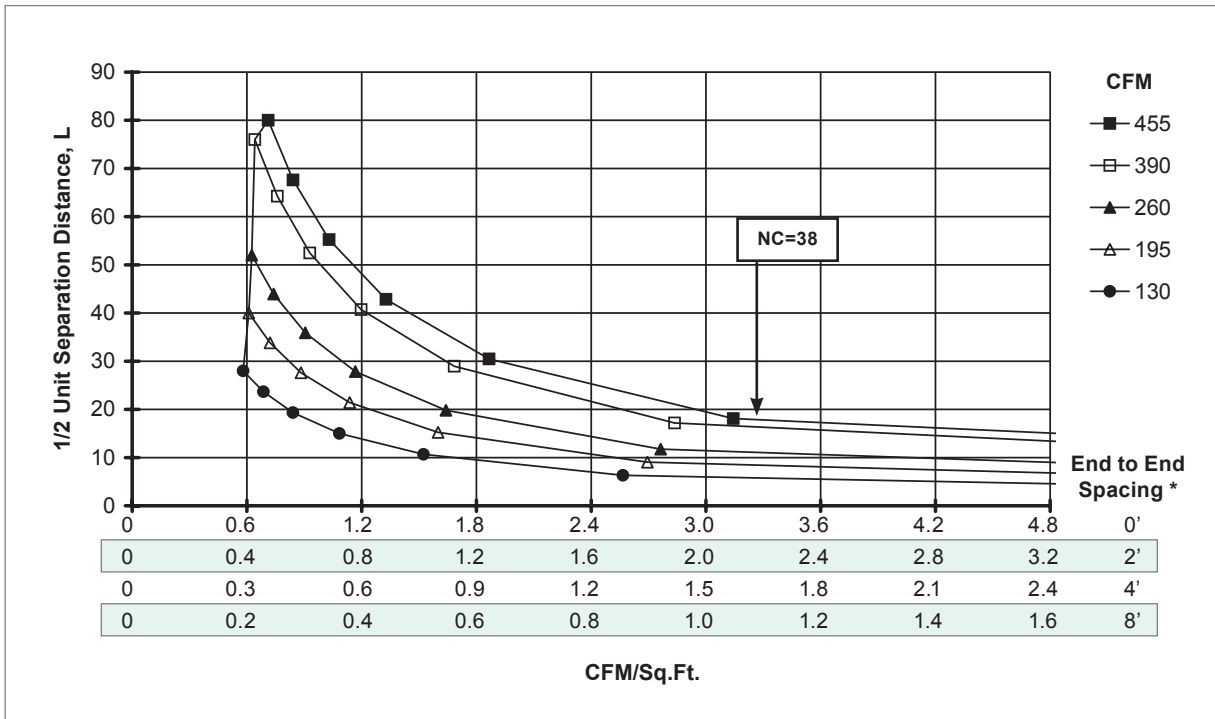
**DIFFUSER SPACING FOR 80% ADPI: DFB/DFNT, 4 FT. LENGTH, 1" SLOT WIDTH, 2-SLOT, 2-WAY, 8" INLET PLENUM**

DESIGN FLO

 NOTES: Charts are at 20 BTUH/ft<sup>2</sup> loads.

See the Engineering section of this catalog for instructions on how to read these charts and additional ADPI information.

\* Separation distance in feet between active supply sections discharging in similar directions.



**DFL Reference Charts: For Lay-In T-Bar (DFB) & Narrow-T (DFNT), Horizontal Throw –**

**DIFFUSER SPACING FOR 80% ADPI: DFB/DFNT, 4 FT. LENGTH, 2" SLOT WIDTH, 1-SLOT, 1-WAY, 8" INLET PLENUM**

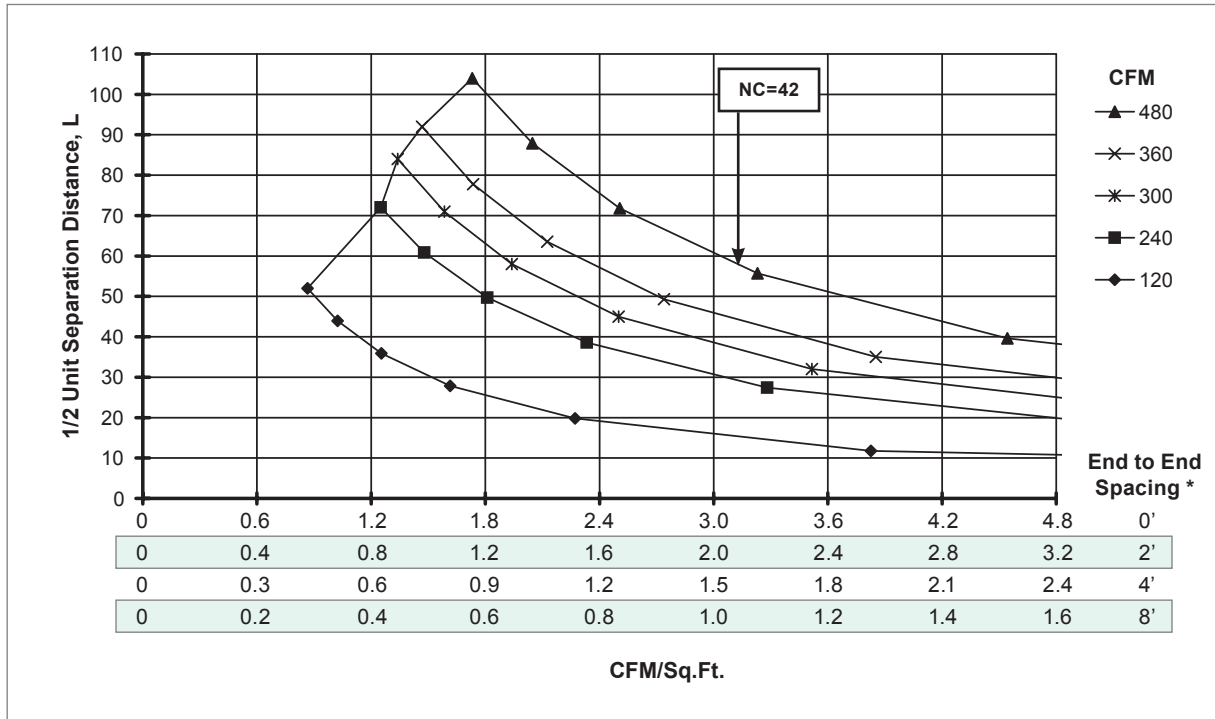

**DIFFUSER SPACING FOR 80% ADPI: DFB/DFNT, 4 FT. LENGTH, 2" SLOT WIDTH, 2-SLOT, 2-WAY, 10" INLET PLENUM**

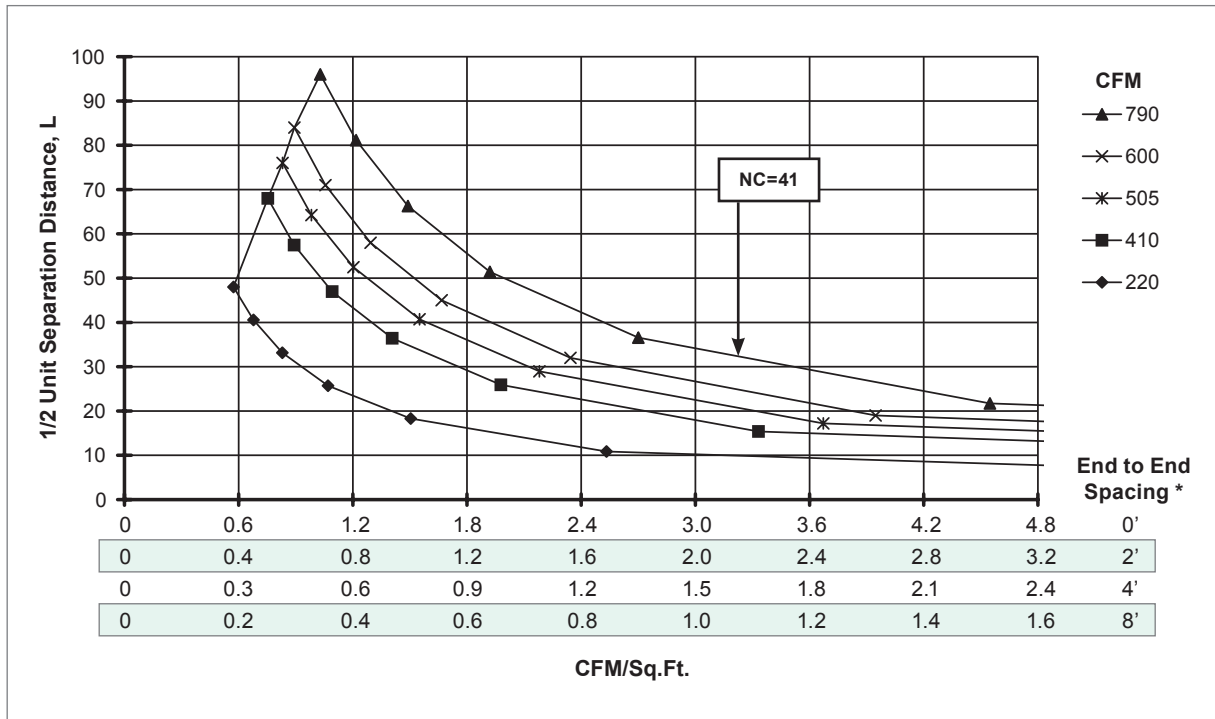

NOTES: Charts are at 20 BTUH/ft<sup>2</sup> loads.

See the Engineering section of this catalog for instructions on how to read these charts and additional ADPI information.

\* Separation distance in feet between active supply sections discharging in similar directions.

LINEAR SLOT DIFFUSERS

DESIGN FLO

**DFL Performance Data: For Lay-In T-Bar (DFB) & Narrow-T (DFNT), Horizontal Throw**
**IP/METRIC DATA: DFB/DFNT, 1-SLOT (HT BLADES)**

Linear Length	IP Data	Air Flow			NC	Metric Data			Octave Band, dB							
		CFM	Pressures			1-Way Throw	Air Flow	Pressures		1-Way Throw	2	3	4	5	6	7
			Pt	Ps				L/s	Pa							
		"WG	"WG	ft		L/s	Pa	Pa	m							
1" Slot Width 6" Inlet	2'	30	0.010	0.009	2 - 4 - 9	-	14	2.6	2.2	0.6 - 1.3 - 2.6	28	26	13	-	-	-
		80	0.074	0.062	8 - 12 - 17	23	38	18.3	15.4	2.3 - 3.5 - 5.2	43	45	36	29	22	14
		105	0.127	0.107	10 - 14 - 20	30	50	31.6	26.6	3.1 - 4.2 - 6.0	47	51	43	36	30	22
		130	0.194	0.164	12 - 15 - 22	35	61	48.4	40.8	3.8 - 4.7 - 6.6	51	55	48	42	37	29
		180	0.372	0.314	15 - 18 - 26	42	85	92.7	78.2	4.5 - 5.5 - 7.8	56	62	56	50	47	38
	4'	60	0.015	0.009	3 - 6 - 12	-	28	3.8	2.2	0.8 - 1.8 - 3.7	30	28	14	-	-	-
		130	0.071	0.041	9 - 13 - 22	22	61	17.8	10.2	2.7 - 4.0 - 6.6	42	44	32	25	16	-
		165	0.115	0.066	11 - 17 - 25	27	78	28.6	16.4	3.4 - 5.1 - 7.5	45	49	38	31	23	16
		200	0.169	0.097	14 - 19 - 27	32	94	42.1	24.1	4.1 - 5.8 - 8.2	48	53	42	36	29	22
		270	0.308	0.177	18 - 22 - 31	39	127	76.7	44.0	5.5 - 6.8 - 9.6	53	59	49	44	38	31
	5'	80	0.021	0.010	3 - 7 - 15	-	38	5.3	2.5	1.0 - 2.2 - 4.4	31	30	15	-	-	-
		170	0.097	0.045	10 - 15 - 25	24	80	24.1	11.2	3.1 - 4.7 - 7.6	43	46	33	26	17	-
		215	0.155	0.072	13 - 20 - 28	30	101	38.6	17.8	4.0 - 6.0 - 8.5	47	50	39	33	24	17
		260	0.227	0.105	16 - 22 - 31	34	123	56.4	26.1	4.8 - 6.6 - 9.4	50	54	43	38	30	23
		350	0.411	0.190	21 - 25 - 36	41	165	102.3	47.3	6.3 - 7.7 - 10.9	54	60	51	46	40	32
1" Slot Width 8" Inlet	2'	40	0.017	0.016	3 - 6 - 12	-	19	4.1	3.9	1.0 - 1.8 - 3.5	33	32	21	12	-	-
		90	0.084	0.078	9 - 13 - 18	25	42	20.9	19.5	2.6 - 3.9 - 5.5	46	48	41	33	27	19
		115	0.137	0.128	11 - 15 - 21	31	54	34.2	31.9	3.4 - 4.4 - 6.2	49	53	46	40	35	27
		140	0.203	0.190	13 - 16 - 23	36	66	50.7	47.3	4.0 - 4.9 - 6.9	53	57	51	45	41	33
		190	0.375	0.350	15 - 19 - 26	43	90	93.3	87.1	4.6 - 5.7 - 8.0	57	63	58	53	51	42
	4'	70	0.015	0.012	4 - 7 - 14	-	33	3.8	3.0	1.1 - 2.2 - 4.3	33	32	19	-	-	-
		150	0.070	0.055	10 - 15 - 23	25	71	17.4	13.6	3.1 - 4.6 - 7.1	45	47	37	30	22	14
		190	0.112	0.087	13 - 19 - 26	30	90	28.0	21.8	3.9 - 5.7 - 8.0	48	52	43	36	29	22
		230	0.165	0.128	16 - 21 - 29	35	109	41.0	31.9	4.8 - 6.2 - 8.8	51	56	47	41	35	27
		310	0.299	0.233	19 - 24 - 34	42	146	74.4	58.0	5.9 - 7.2 - 10.2	56	62	54	49	44	36
	5'	90	0.018	0.013	4 - 8 - 16	-	42	4.5	3.1	1.3 - 2.5 - 5.0	34	33	20	11	-	-
		190	0.081	0.056	12 - 17 - 26	26	90	20.1	13.9	3.5 - 5.3 - 8.0	46	48	38	31	22	15
		240	0.129	0.089	15 - 21 - 30	32	113	32.1	22.2	4.4 - 6.4 - 9.0	49	53	43	37	30	22
		290	0.188	0.130	18 - 23 - 33	36	137	46.9	32.5	5.4 - 7.0 - 9.9	52	57	48	42	36	28
		390	0.341	0.236	22 - 27 - 38	43	184	84.8	58.7	6.6 - 8.1 - 11.5	57	63	55	50	45	37
1.5" Slot Width 8" Inlet	2'	70	0.027	0.026	6 - 8 - 16	-	33	6.8	6.4	1.8 - 2.7 - 4.7	30	29	20	12	-	-
		130	0.101	0.089	10 - 15 - 21	20	61	25.1	22.2	3.3 - 4.6 - 6.5	43	44	36	31	25	15
		160	0.153	0.135	13 - 17 - 24	26	76	38.0	33.6	4.0 - 5.1 - 7.2	47	49	41	37	32	22
		190	0.215	0.191	15 - 18 - 26	30	90	53.6	47.4	4.5 - 5.5 - 7.8	51	53	46	42	39	29
		250	0.373	0.330	17 - 21 - 30	37	118	92.8	82.1	5.2 - 6.3 - 9.0	57	60	53	51	49	39
	4'	110	0.024	0.016	6 - 9 - 18	-	52	6.0	4.0	2.0 - 2.9 - 5.9	30	29	18	-	-	-
		210	0.089	0.058	12 - 18 - 27	22	99	22.0	14.5	3.8 - 5.6 - 8.2	44	44	34	29	21	12
		260	0.136	0.089	15 - 21 - 30	28	123	33.8	22.2	4.6 - 6.5 - 9.1	48	50	40	35	29	20
		310	0.193	0.127	17 - 23 - 33	33	146	48.0	31.6	5.5 - 7.1 - 10.0	52	54	44	40	35	26
		410	0.337	0.222	22 - 27 - 38	40	193	84.0	55.2	6.6 - 8.1 - 11.5	58	61	52	49	45	37
	5'	140	0.030	0.017	7 - 10 - 21	-	66	7.5	4.1	2.2 - 3.4 - 6.7	32	31	19	11	-	-
		250	0.096	0.053	12 - 19 - 30	24	118	23.8	13.1	4.0 - 6.0 - 9.0	45	45	34	28	20	12
		305	0.143	0.079	15 - 23 - 33	29	144	35.5	19.6	4.9 - 7.0 - 9.9	49	50	39	34	27	19
		360	0.199	0.109	18 - 25 - 35	33	170	49.5	27.2	5.8 - 7.6 - 10.8	52	54	44	39	34	25
		470	0.339	0.187	23 - 29 - 40	40	222	84.3	46.4	7.1 - 8.7 - 12.3	58	60	50	47	43	35
1.5" Slot Width 10" Inlet	2'	80	0.035	0.034	6 - 9 - 17	-	38	8.7	8.4	2.0 - 3.0 - 5.1	32	31	23	16	-	-
		140	0.111	0.103	11 - 16 - 22	20	66	27.5	25.8	3.5 - 4.7 - 6.7	44	45	38	33	27	16
		170	0.163	0.153	13 - 17 - 24	25	80	40.6	38.0	4.3 - 5.2 - 7.4	48	49	43	39	34	24
		200	0.226	0.211	15 - 19 - 26	29	94	56.2	52.6	4.6 - 5.7 - 8.0	51	53	47	43	40	30
		260	0.381	0.357	17 - 21 - 30	36	123	94.9	88.8	5.3 - 6.5 - 9.1	57	59	54	51	50	40
	4'	140	0.033	0.026	8 - 12 - 22	-	66	8.2	6.4	2.5 - 3.8 - 6.7	34	34	23	16	-	-
		240	0.097	0.076	13 - 20 - 29	24	113	24.1	18.9	4.3 - 6.2 - 8.8	46	46	37	32	25	16
		290	0.142	0.111	16 - 22 - 32	29	137	35.2	27.6	5.2 - 6.8 - 9.7	50	51	42	38	32	23
		340	0.195	0.153	19 - 24 - 34	33	160	48.4	38.0	6.0 - 7.4 - 10.5	53	55	46	43	38	29
		440	0.326	0.255	23 - 28 - 39	40	208	81.1	63.6	6.9 - 8.4 - 11.9	58	61	53	50	47	38
	5'	170	0.035	0.024	8 - 13 - 24	11	80	8.7	6.1	2.7 - 4.1 - 7.4	35	35	24	16	-	-
		280	0.095	0.066	14 - 21 - 31	24	132	23.6	16.5	4.5 - 6.7 - 9.5	46	47	37	31	24	15
		335	0.136	0.095	17 - 24 - 34	29	158	33.8	23.6	5.4 - 7.3 - 10.4	50	51	41	37	31	22
		390	0.184	0.128	19 - 26 - 37	33	184	45.8	32.0	6.2 - 7.9 - 11.2	53	55	45	41	36	27
		500	0.302	0.211	24 - 30 - 42	40	236	75.2	52.6	7.3 - 9.0 - 12.7	58	61	52	49	45	37

LINEAR SLOT DIFFUSERS

DESIGN FLO

**DFL Performance Data: For Lay-In T-Bar (DFB) & Narrow-T (DFNT), Horizontal Throw**

IP/METRIC DATA: DFB/DFNT, 1-SLOT (HT BLADES)

	Linear Length	IP Data				NC	Metric Data				Octave Band, dB						
		Air Flow	Pressures		1-Way Throw		Air Flow	Pressures		1-Way Throw	2	3	4	5	6	7	
			Pt	Ps				Pt	Ps								
		CFM	"WG	"WG	ft		L/s	Pa	Pa	m							
2" Slot Width	2'	80	0.029	0.027	8 - 11 - 15	-	38	7.2	6.8	2.4 - 3.2 - 4.6	39	33	22	14	-	-	
		140	0.097	0.084	11 - 14 - 20	22	66	24.3	20.9	3.5 - 4.3 - 6.0	47	45	36	31	26	12	
		170	0.144	0.124	13 - 15 - 22	27	80	35.8	30.8	3.8 - 4.7 - 6.7	50	49	41	37	34	20	
		200	0.199	0.171	14 - 17 - 24	31	94	49.5	42.7	4.2 - 5.1 - 7.2	52	52	45	42	40	28	
	260	0.336	0.290	16 - 19 - 27	38	123	83.7	72.1	4.7 - 5.8 - 8.2	56	57	51	50	51	39		
	4'	120	0.025	0.015	9 - 13 - 18	-	57	6.3	3.8	2.6 - 3.9 - 5.6	36	32	19	-	-	-	
		240	0.101	0.062	15 - 18 - 26	24	113	25.2	15.4	4.6 - 5.6 - 7.9	46	46	36	30	23	11	
		300	0.158	0.096	17 - 21 - 29	29	142	39.4	24.0	5.1 - 6.2 - 8.8	49	51	41	37	32	20	
		360	0.228	0.139	18 - 23 - 32	34	170	56.8	34.6	5.6 - 6.8 - 9.7	52	54	46	42	39	28	
	8' Inlet	480	0.405	0.247	21 - 26 - 37	42	227	100.9	61.4	6.5 - 7.9 - 11.2	56	60	53	51	51	41	
		150	0.031	0.015	10 - 14 - 21	-	71	7.7	3.8	2.9 - 4.3 - 6.2	37	33	20	-	-	-	
		290	0.116	0.058	16 - 20 - 29	24	137	28.8	14.4	5.0 - 6.1 - 8.7	46	47	36	30	22	11	
360		0.178	0.089	18 - 23 - 32	30	170	44.3	22.1	5.6 - 6.8 - 9.7	49	51	41	37	31	20		
5'	430	0.254	0.127	20 - 25 - 35	35	203	63.2	31.6	6.1 - 7.5 - 10.6	51	55	45	42	38	28		
	570	0.446	0.223	23 - 28 - 40	42	269	111.1	55.4	7.0 - 8.6 - 12.2	55	61	52	51	50	40		
	10" Slot Width	2'	90	0.036	0.035	9 - 11 - 16	-	42	8.9	8.6	2.7 - 3.4 - 4.8	42	35	25	17	-	-
			160	0.119	0.110	12 - 15 - 21	24	76	29.6	27.3	3.7 - 4.6 - 6.5	50	47	39	35	31	17
195			0.177	0.163	14 - 17 - 23	29	92	44.0	40.6	4.1 - 5.0 - 7.1	53	51	44	41	39	25	
230			0.246	0.227	15 - 18 - 25	34	109	61.2	56.4	4.5 - 5.5 - 7.7	55	54	48	46	46	33	
4'		300	0.418	0.386	17 - 21 - 29	41	142	104.1	96.0	5.1 - 6.2 - 8.8	59	60	54	54	57	44	
		150	0.032	0.024	11 - 15 - 21	-	71	8.0	6.0	3.2 - 4.4 - 6.2	40	36	24	16	-	-	
		270	0.105	0.078	16 - 19 - 28	25	127	26.0	19.4	4.8 - 5.9 - 8.4	49	48	38	33	27	15	
		330	0.156	0.117	18 - 22 - 30	31	156	38.9	29.0	5.4 - 6.6 - 9.3	51	52	43	39	36	23	
5'		390	0.218	0.163	19 - 23 - 33	35	184	54.3	40.6	5.8 - 7.1 - 10.1	54	55	47	44	42	31	
		510	0.373	0.279	22 - 27 - 38	42	241	92.9	69.4	6.7 - 8.1 - 11.5	57	61	54	53	53	42	
		170	0.030	0.020	11 - 15 - 22	-	80	7.5	4.9	3.3 - 4.7 - 6.7	39	35	23	14	-	-	
		310	0.101	0.066	17 - 21 - 30	25	146	25.1	16.4	5.2 - 6.4 - 9.0	48	47	37	32	25	13	
5'	380	0.151	0.099	19 - 23 - 33	30	179	37.7	24.6	5.7 - 7.0 - 9.9	51	52	42	38	33	22		
	450	0.212	0.139	21 - 25 - 36	35	212	52.9	34.6	6.2 - 7.7 - 10.8	53	55	46	43	40	29		
	590	0.365	0.239	24 - 29 - 41	42	278	90.9	59.4	7.2 - 8.8 - 12.4	57	61	53	51	51	41		
	2.5" Slot Width	2'	140	0.050	0.043	9 - 11 - 15	11	66	12.5	10.8	2.7 - 3.3 - 4.6	36	35	28	23	16	-
240			0.148	0.127	12 - 14 - 20	26	113	36.9	31.6	3.5 - 4.3 - 6.1	47	48	41	38	34	18	
290			0.216	0.186	13 - 16 - 22	32	137	53.8	46.2	3.8 - 4.7 - 6.7	52	52	45	43	40	24	
340			0.297	0.255	14 - 17 - 24	36	160	74.0	63.5	4.2 - 5.1 - 7.2	55	56	49	48	45	30	
4'		440	0.498	0.427	16 - 19 - 27	43	208	123.9	106.4	4.7 - 5.8 - 8.2	61	62	55	55	54	39	
		170	0.026	0.016	8 - 12 - 17	-	80	6.6	4.0	2.3 - 3.5 - 5.1	36	34	25	20	11	-	
		310	0.088	0.053	13 - 16 - 23	27	146	21.9	13.2	4.0 - 4.9 - 6.9	49	48	40	37	31	18	
		380	0.132	0.080	14 - 18 - 25	32	179	32.9	19.8	4.4 - 5.4 - 7.6	53	53	45	42	38	25	
5'		450	0.185	0.112	16 - 19 - 27	37	212	46.2	27.8	4.8 - 5.9 - 8.3	57	57	49	47	43	31	
		590	0.319	0.192	18 - 22 - 31	45	278	79.3	47.8	5.5 - 6.7 - 9.5	63	63	55	54	52	41	
		200	0.029	0.014	8 - 12 - 18	12	94	7.1	3.5	2.5 - 3.7 - 5.5	38	36	27	22	13	-	
		340	0.083	0.041	14 - 17 - 24	27	160	20.6	10.2	4.2 - 5.1 - 7.2	49	49	40	36	31	18	
5'	410	0.120	0.059	15 - 18 - 26	32	193	30.0	14.8	4.6 - 5.6 - 7.9	53	53	44	42	37	25		
	480	0.165	0.081	16 - 20 - 28	37	227	41.1	20.3	5.0 - 6.1 - 8.6	57	57	48	46	42	31		
	620	0.276	0.136	19 - 23 - 32	44	293	68.6	33.8	5.6 - 6.9 - 9.8	62	63	54	53	50	40		
	12" Slot Width	2'	150	0.053	0.050	9 - 11 - 16	-	71	13.1	12.4	2.8 - 3.4 - 4.8	32	31	24	20	12	-
260			0.158	0.149	12 - 15 - 21	22	123	39.4	37.1	3.6 - 4.5 - 6.3	44	44	38	35	30	11	
315			0.232	0.219	13 - 16 - 23	27	149	57.8	54.5	4.0 - 4.9 - 6.9	48	48	42	40	36	18	
370			0.320	0.302	14 - 18 - 25	31	175	79.8	75.2	4.3 - 5.3 - 7.5	51	52	46	45	41	24	
4'		480	0.539	0.508	16 - 20 - 28	39	227	134.3	126.6	5.0 - 6.1 - 8.6	57	58	53	52	50	33	
		180	0.022	0.018	8 - 12 - 17	-	85	5.5	4.5	2.5 - 3.7 - 5.3	31	30	22	16	-	-	
		340	0.079	0.064	14 - 17 - 24	22	160	19.7	15.9	4.2 - 5.1 - 7.2	45	45	37	34	28	12	
		420	0.121	0.097	15 - 19 - 26	28	198	30.1	24.2	4.6 - 5.7 - 8.0	50	50	42	40	35	19	
5'		500	0.172	0.138	17 - 20 - 29	33	236	42.7	34.3	5.1 - 6.2 - 8.8	54	54	47	44	40	26	
		660	0.299	0.240	19 - 23 - 33	41	311	74.4	59.8	5.8 - 7.1 - 10.1	60	60	53	52	50	36	
		210	0.021	0.016	8 - 13 - 19	-	99	5.4	3.9	2.6 - 3.9 - 5.7	33	32	23	18	-	-	
		380	0.070	0.051	14 - 18 - 25	23	179	17.5	12.7	4.4 - 5.4 - 7.6	46	46	38	34	28	13	
5'	465	0.105	0.076	16 - 20 - 28	29	219	26.2	19.0	4.9 - 6.0 - 8.4	51	50	43	40	35	20		
	550	0.147	0.107	17 - 21 - 30	34	260	36.7	26.6	5.3 - 6.5 - 9.2	54	54	47	44	40	26		
	720	0.253	0.183	20 - 24 - 35	41	340	62.9	45.6	6.1 - 7.4 - 10.5	60	61	53	52	49	36		

NOTE: See notes on page E1-21.

LINEAR SLOT DIFFUSERS

DESIGN FLO

© KRUEGER 2012

**DFL Performance Data: For Lay-In T-Bar (DFB) & Narrow-T (DFNT), Horizontal Throw**
**IP/METRIC DATA: DFB/DFNT, 1-SLOT (HT BLADES)**

	Linear Length	IP Data				NC	Metric Data				Octave Band, dB						
		Air Flow	Pressures		1-Way Throw		Air Flow	Pressures		1-Way Throw	2	3	4	5	6	7	
			Pt	Ps				Pt	Ps								
		CFM	"WG	"WG	ft		L/s	Pa	Pa	m							
3" Slot Width 10" Inlet	2'	170	0.053	0.046	11 - 13 - 18	25	80	13.3	11.5	3.2 - 3.9 - 5.5	38	37	27	23	14	-	
		250	0.123	0.100	13 - 16 - 22	36	118	30.6	24.9	3.9 - 4.7 - 6.7	46	46	37	34	27	12	
		290	0.165	0.135	14 - 17 - 24	40	137	41.2	33.6	4.2 - 5.1 - 7.2	50	49	41	38	32	17	
		330	0.214	0.175	15 - 18 - 25	43	156	53.3	43.5	4.4 - 5.4 - 7.7	52	52	44	42	36	21	
		410	0.331	0.269	16 - 20 - 28	49	193	82.3	67.1	5.0 - 6.1 - 8.6	57	57	49	48	44	28	
	4'	190	0.028	0.014	11 - 14 - 19	22	90	6.9	3.6	3.4 - 4.1 - 5.8	36	34	24	19	-	-	
		300	0.069	0.036	14 - 17 - 24	34	142	17.1	9.0	4.2 - 5.2 - 7.3	46	45	35	31	24	12	
		355	0.096	0.050	15 - 19 - 26	39	168	24.0	12.6	4.6 - 5.7 - 8.0	50	49	40	36	30	17	
		410	0.128	0.067	16 - 20 - 28	43	193	32.0	16.8	5.0 - 6.1 - 8.6	53	52	43	40	35	22	
		520	0.207	0.108	18 - 22 - 32	49	245	51.5	27.0	5.6 - 6.8 - 9.7	58	58	49	47	43	30	
	5'	200	0.025	0.010	11 - 14 - 20	21	94	6.2	2.6	3.4 - 4.2 - 6.0	36	34	23	18	-	-	
		320	0.064	0.026	14 - 18 - 25	34	151	15.8	6.5	4.4 - 5.4 - 7.6	46	45	35	31	24	12	
		380	0.090	0.037	16 - 19 - 27	39	179	22.3	9.2	4.8 - 5.8 - 8.3	50	49	39	36	29	18	
		440	0.120	0.050	17 - 21 - 29	43	208	29.9	12.4	5.1 - 6.3 - 8.9	53	52	43	40	34	23	
		560	0.194	0.080	19 - 23 - 33	49	264	48.4	20.0	5.8 - 7.1 - 10.0	58	58	49	47	43	31	
3" Slot Width 12" Inlet	2'	160	0.044	0.041	10 - 12 - 18	16	76	11.0	10.2	3.1 - 3.8 - 5.4	31	30	20	15	-	-	
		240	0.100	0.092	12 - 15 - 22	27	113	24.9	23.0	3.8 - 4.6 - 6.6	40	39	30	26	18	-	
		280	0.136	0.126	13 - 17 - 23	32	132	33.9	31.3	4.1 - 5.0 - 7.1	43	43	34	31	23	-	
		320	0.178	0.164	14 - 18 - 25	35	151	44.3	40.9	4.4 - 5.4 - 7.6	46	46	37	35	27	-	
		400	0.278	0.256	16 - 20 - 28	41	189	69.2	63.8	4.9 - 6.0 - 8.5	51	51	43	41	35	17	
	4'	190	0.019	0.014	11 - 14 - 19	15	90	4.8	3.6	3.4 - 4.1 - 5.8	30	29	18	12	-	-	
		330	0.058	0.044	15 - 18 - 25	30	156	14.5	10.9	4.4 - 5.4 - 7.7	42	42	32	28	19	-	
		400	0.086	0.064	16 - 20 - 28	35	189	21.3	16.0	4.9 - 6.0 - 8.5	47	46	37	33	26	11	
		470	0.118	0.089	17 - 21 - 30	40	222	29.4	22.0	5.3 - 6.5 - 9.2	50	50	41	38	31	16	
		610	0.199	0.149	20 - 24 - 34	47	288	49.6	37.1	6.0 - 7.4 - 10.5	56	56	47	45	40	25	
	5'	230	0.021	0.014	12 - 15 - 21	18	109	5.1	3.4	3.7 - 4.5 - 6.4	33	31	21	15	-	-	
		370	0.054	0.035	15 - 19 - 27	31	175	13.3	8.7	4.7 - 5.8 - 8.2	44	42	33	29	20	-	
		440	0.076	0.050	17 - 21 - 29	36	208	18.8	12.4	5.1 - 6.3 - 8.9	47	46	37	33	26	12	
		510	0.102	0.067	18 - 22 - 32	40	241	25.3	16.6	5.5 - 6.8 - 9.6	51	50	41	38	31	17	
		650	0.165	0.108	21 - 25 - 36	46	307	41.1	27.0	6.2 - 7.6 - 10.8	56	56	47	44	39	26	

NOTES: Throw values are given for terminal velocities of 150, 100, and 50 FPM (0.75, 0.50, and 0.25 m/s). NC values are based on octave band 2-7 sound power levels minus a room absorption of 10dB, re 10<sup>-12</sup> Watts. Dash in space denotes a NC or dB value of less than 10. Data was obtained from tests conducted in accordance with ANSI/ASHRAE Standard 70, ISO Standard 5219, and ISO Standard 3741. For return applications, add 3 NC to supply data; static pressure is equal to supply total pressure. See selection software for performance data not shown, including octave band data.

**DFL Performance Data: For Lay-In T-Bar (DFB) & Narrow-T (DFNT), Horizontal Throw -**

IP/METRIC DATA: DFB/DFNT, 2-SLOT (HT BLADES)

LINEAR SLOT DIFFUSERS	Linear Length	Slot Width	Inlet	IP Data					Metric Data					Octave Band, dB						
				Air Flow	Pressure		1-Way Throw	2-Way Throw	NC	Air Flow	Pressure		1-Way Throw	2-Way Throw	2	3	4	5	6	7
					Pt	Ps					Pt	Ps								
				CFM	"WG	"WG	ft	ft	L/s	Pa	Pa	m	m							
1" Slot Width	2'	8" Inlet	60	0.011	0.009	3-6-12	2-4-9	-	28	2.8	2.2	0.8-1.8-3.7	0.6-1.3-2.6	30	29	15	-	-	-	
			140	0.061	0.047	10-14-23	7-10-16	23	66	15.2	11.8	2.9-4.3-6.9	2.0-3.1-4.9	44	46	35	28	20	12	
			180	0.101	0.078	12-18-26	9-13-18	29	85	25.1	19.5	3.7-5.5-7.8	2.6-3.9-5.5	48	51	41	35	28	20	
			220	0.151	0.117	15-20-28	11-14-20	34	104	37.5	29.2	4.5-6.1-8.6	3.2-4.3-6.1	51	55	46	40	34	26	
			300	0.280	0.218	19-23-33	14-17-23	41	142	69.7	54.3	5.8-7.1-10.1	4.1-5.0-7.1	56	61	53	48	43	35	
	4'	120	0.019	0.009	4-8-17	3-6-12	-	57	4.6	2.2	1.1-2.6-5.3	0.8-1.8-3.7	32	31	16	-	-	-		
		250	0.081	0.038	12-18-30	8-13-21	24	118	20.1	9.4	3.7-5.5-9.2	2.6-3.9-6.5	44	46	33	26	16	-		
		315	0.128	0.060	15-23-34	11-16-24	29	149	32.0	15.0	4.6-6.9-10.3	3.3-4.9-7.3	47	51	39	32	24	17		
		380	0.187	0.087	18-26-37	13-19-26	34	179	46.5	21.8	5.6-8.0-11.3	3.9-5.7-8.0	50	54	43	37	30	22		
		510	0.337	0.158	25-31-43	17-22-31	41	241	83.8	39.2	7.4-9.3-13.1	5.3-6.6-9.3	55	60	50	45	39	31		
	5'	140	0.021	0.008	4-8-18	3-6-13	-	66	5.3	1.9	1.1-2.5-5.5	0.8-1.8-3.9	32	31	14	-	-	-		
		290	0.090	0.033	12-19-33	9-13-23	23	137	22.5	8.1	3.8-5.7-9.9	2.7-4.0-7.0	43	45	32	25	14	-		
365		0.143	0.052	16-24-37	11-17-26	29	172	35.7	12.9	4.8-7.2-11.1	3.4-5.1-7.9	47	50	37	31	21	15			
440		0.208	0.075	19-28-40	13-20-28	33	208	51.9	18.7	5.7-8.6-12.2	4.1-6.1-8.6	50	54	42	36	27	20			
590		0.374	0.135	25-33-46	18-23-33	40	278	93.2	33.6	7.7-10.0-14.1	5.5-7.1-10.0	54	60	49	44	36	29			
10" Inlet	2'	70	0.014	0.012	4-7-14	3-5-10	-	33	3.4	3.0	1.1-2.2-4.3	0.8-1.5-3.1	33	32	20	-	-	-		
		150	0.063	0.055	10-15-23	7-11-17	24	71	15.6	13.6	3.1-4.6-7.1	2.2-3.3-5.0	45	47	38	31	23	16		
		190	0.101	0.087	13-19-26	9-13-19	30	90	25.0	21.8	3.9-5.7-8.0	2.8-4.0-5.7	49	52	44	37	30	23		
		230	0.147	0.128	16-21-29	11-15-21	35	109	36.7	31.9	4.8-6.2-8.8	3.4-4.4-6.2	52	56	48	42	36	28		
		310	0.268	0.233	19-24-34	14-17-24	42	146	66.7	58.0	5.9-7.2-10.2	4.2-5.1-7.2	57	62	55	50	46	37		
	4'	130	0.016	0.010	4-9-19	3-7-13	-	61	4.1	2.5	1.3-2.8-5.7	0.9-2.0-4.0	34	33	19	-	-	-		
		260	0.066	0.041	12-19-31	9-13-22	25	123	16.3	10.2	3.8-5.7-9.4	2.7-4.0-6.6	45	47	35	28	19	12		
		325	0.102	0.064	16-23-34	11-17-24	30	153	25.5	15.9	4.7-7.1-10.5	3.4-5.0-7.4	48	51	41	34	26	19		
		390	0.147	0.092	19-27-38	13-19-27	34	184	36.7	22.9	5.7-8.1-11.5	4.0-5.7-8.1	51	55	45	39	32	24		
		520	0.262	0.164	25-31-44	18-22-31	41	245	65.3	40.8	7.6-9.4-13.3	5.4-6.6-9.4	56	61	52	46	41	33		
	5'	150	0.017	0.009	4-9-19	3-7-14	-	71	4.2	2.2	1.3-2.9-5.9	0.9-2.0-4.2	33	32	17	-	-	-		
		300	0.068	0.035	13-19-33	9-14-23	24	142	16.8	8.7	3.9-5.9-10.1	2.8-4.2-7.1	44	46	34	26	17	-		
375		0.106	0.055	16-24-37	11-17-26	29	177	26.3	13.6	4.9-7.3-11.3	3.5-5.2-8.0	48	51	39	32	24	16			
450		0.152	0.078	19-29-41	14-20-29	34	212	37.9	19.5	5.9-8.7-12.3	4.2-6.2-8.7	51	54	43	37	29	22			
600		0.270	0.140	26-33-47	18-23-33	40	283	67.4	34.7	7.8-10.1-14.2	5.5-7.1-10.1	55	60	50	45	38	31			
1.5" Slot Width	2'	8" Inlet	80	0.011	0.008	4-7-13	3-5-9	-	38	2.7	2.1	1.4-2.1-4.3	1.0-1.5-3.0	24	21	-	-	-	-	
			180	0.065	0.043	10-15-25	7-11-18	18	85	16.2	10.6	3.2-4.8-7.6	2.3-3.4-5.4	41	41	30	24	15	-	
			230	0.106	0.070	13-19-28	9-14-20	25	109	26.4	17.4	4.1-6.1-8.6	2.9-4.3-6.1	46	47	37	31	24	15	
			280	0.157	0.103	16-22-31	11-16-22	30	132	39.2	25.8	5.0-6.7-9.5	3.5-4.7-6.7	50	51	42	37	31	22	
			380	0.290	0.191	21-26-36	15-18-26	38	179	72.2	47.4	6.4-7.8-11.1	4.5-5.5-7.8	56	59	50	46	42	34	
	4'	140	0.020	0.006	6-8-17	4-6-12	-	66	5.0	1.6	1.8-2.7-5.3	1.3-1.9-3.8	26	24	-	-	-	-		
		300	0.092	0.030	12-18-32	8-13-23	21	142	22.8	7.4	3.8-5.7-9.8	2.7-4.0-7.0	42	42	29	23	12	-		
		380	0.147	0.048	15-23-36	11-16-26	27	179	36.6	11.9	4.8-7.2-11.1	3.4-5.1-7.8	47	48	35	30	21	13		
		460	0.215	0.070	18-27-40	13-19-28	32	217	53.6	17.4	5.8-8.6-12.2	4.1-6.1-8.6	51	52	40	35	28	20		
		620	0.391	0.127	24-33-46	17-23-33	40	293	97.4	31.6	7.8-10.0-14.1	5.5-7.1-10.0	57	59	48	44	39	31		
	5'	160	0.023	0.005	6-8-17	4-6-12	-	76	5.7	1.3	1.8-2.7-5.4	1.3-1.9-3.8	26	23	-	-	-	-		
		340	0.104	0.024	12-18-34	8-13-24	21	160	25.9	6.1	3.8-5.8-10.5	2.7-4.1-7.4	42	41	28	21	-	-		
430		0.166	0.039	15-23-39	11-16-27	27	203	41.4	9.7	4.9-7.3-11.8	3.4-5.2-8.3	47	47	34	28	18	11			
520		0.243	0.057	18-28-43	13-19-30	32	245	60.5	14.2	5.9-8.8-12.9	4.2-6.2-9.2	51	52	39	34	25	18			
700		0.441	0.103	25-35-49	17-25-35	40	330	109.7	25.8	7.9-10.6-15.0	5.6-7.5-10.6	57	59	47	43	36	29			
1.5" Slot Width	2'	12" Inlet	140	0.027	0.026	8-12-22	6-8-16	-	66	6.6	6.4	2.5-3.8-6.7	1.8-2.7-4.7	33	32	23	15	-	-	
			250	0.091	0.082	14-21-30	10-15-21	21	118	22.6	20.5	4.5-6.3-9.0	3.2-4.5-6.3	45	46	38	33	26	16	
			305	0.135	0.123	17-23-33	12-16-23	27	144	33.7	30.6	5.5-7.0-9.9	3.9-5.0-7.0	49	50	43	39	34	23	
			360	0.188	0.171	20-25-35	14-18-25	31	170	46.9	42.6	6.2-7.6-10.8	4.4-5.4-7.6	53	54	47	44	40	29	
			470	0.321	0.291	23-29-40	17-20-29	38	222	80.0	72.6	7.1-8.7-12.3	5.0-6.2-8.7	58	61	54	51	49	39	
	4'	220	0.022	0.016	9-13-26	6-9-18	-	104	5.6	4.0	2.8-4.2-8.3	2.0-2.9-5.9	33	31	20	12	-	-		
		390	0.071	0.050	15-23-37	11-16-26	23	184	17.6	12.5	4.9-7.4-11.2	3.5-5.2-7.9	45	45	35	29	21	12		
		475	0.105	0.074	19-28-41	13-20-29	28	224	26.1	18.5	6.0-8.7-12.4	4.2-6.2-8.7	49	50	40	35	28	19		
		560	0.146	0.103	22-31-44	16-22-31	32	264	36.3	25.8	7.1-9.5-13.4	5.0-6.7-9.5	53	54	45	40	34	25		
		730	0.247	0.176	29-36-50	20-25-36	39	345	61.6	43.8	8.9-10.8-15.3	6.3-7.7-10.8	58	60	51	48	44	35		
	5'	260	0.023	0.014	9-14-28	6-10-19	-	123	5.8	3.6	2.9-4.4-8.8	2.1-3.1-6.2	33	32	20	12	-	-		
		450	0.070	0.043	16-24-40	11-17-28	23	212	17.4	10.6	5.1-7.6-12.0	3.6-5.4-8.5	45	45	34	28	19	-		
545		0.103	0.063	19-29-44	14-20-31	28	257	25.6	15.6	6.2-9.2-13.2	4.4-6.5-9.4	49	50	39	34	26	17			
640		0.142	0.086	23-33-47	16-24-33	32	302	35.2	21.5	7.2-10.2-14.4	5.1-7.2-10.2	52	54	43	39	32	23			
830		0.238	0.145	29-38-54	21-27-38	39	392	59.3	36.2	9.4-11.6-16.3	6.6-8.2-11.6	58	60	50	46	42	33			

NOTE: See notes on page E1-24.

© KRUEGER 2012

**DFL Performance Data: For Lay-In T-Bar (DFB) & Narrow-T (DFNT), Horizontal Throw**
**IP/METRIC DATA: DFB/DFNT, 2-SLOT (HT BLADES)**

Linear Length	Slot Width	Inlet	IP Data					NC	Metric Data					Octave Band, dB						
			Air Flow	Pressure		1-Way Throw	2-Way Throw		Air Flow	Pressure		1-Way Throw	2-Way Throw	2	3	4	5	6	7	
				"WG	"WG					Pt	Ps									L/s
			CFM	"WG	"WG	ft	ft		L/s	Pa	Pa	m	m							
2'	10" Inlet	140	0.022	0.021	10 - 14 - 20	7 - 10 - 14	-	66	5.6	5.2	3.0 - 4.3 - 6.0	2.1 - 3.0 - 4.3	39	34	22	13	-	-		
		260	0.097	0.072	16 - 19 - 27	11 - 14 - 19	24	123	24.1	18.0	4.7 - 5.8 - 8.2	3.4 - 4.1 - 5.8	48	47	37	32	26	13		
		320	0.147	0.110	17 - 21 - 30	12 - 15 - 21	30	151	36.6	27.3	5.3 - 6.5 - 9.1	3.7 - 4.6 - 6.5	51	51	42	38	34	22		
		380	0.207	0.155	19 - 23 - 33	13 - 16 - 23	34	179	51.6	38.5	5.7 - 7.0 - 9.9	4.1 - 5.0 - 7.0	53	55	47	44	41	30		
		500	0.359	0.268	22 - 27 - 38	15 - 19 - 27	42	236	89.3	66.7	6.6 - 8.1 - 11.4	4.7 - 5.7 - 8.1	57	60	53	52	52	41		
	4'	220	0.031	0.013	11 - 17 - 25	8 - 12 - 18	-	104	7.6	3.2	3.3 - 4.9 - 7.6	2.3 - 3.5 - 5.4	37	34	20	-	-	-		
		410	0.106	0.045	20 - 24 - 34	14 - 17 - 24	24	193	26.4	11.2	6.0 - 7.3 - 10.3	4.2 - 5.2 - 7.3	46	47	35	29	19	-		
		505	0.161	0.068	22 - 27 - 38	15 - 19 - 27	29	238	40.1	17.0	6.6 - 8.1 - 11.5	4.7 - 5.7 - 8.1	49	51	40	35	28	17		
		600	0.227	0.096	24 - 29 - 41	17 - 21 - 29	34	283	56.6	24.0	7.2 - 8.8 - 12.5	5.1 - 6.2 - 8.8	51	54	44	40	35	25		
		790	0.394	0.167	27 - 33 - 47	19 - 24 - 33	41	373	98.1	41.6	8.3 - 10.1 - 14.3	5.9 - 7.2 - 10.1	55	60	51	49	46	36		
5'	260	0.036	0.012	12 - 18 - 27	8 - 12 - 19	-	123	9.0	2.9	3.3 - 5.2 - 8.2	2.3 - 3.7 - 5.8	37	34	19	-	-	-			
	480	0.123	0.039	21 - 26 - 37	15 - 18 - 26	24	227	30.7	9.8	6.4 - 7.9 - 11.2	4.5 - 5.6 - 7.9	45	47	34	28	18	-			
	590	0.186	0.060	24 - 29 - 41	17 - 20 - 29	29	278	46.4	14.9	7.2 - 8.8 - 12.4	5.1 - 6.2 - 8.8	48	51	39	34	26	16			
	700	0.262	0.084	26 - 31 - 44	18 - 22 - 31	34	330	65.3	20.9	7.8 - 9.5 - 13.5	5.5 - 6.7 - 9.5	50	54	44	39	33	23			
	920	0.453	0.145	29 - 36 - 51	21 - 25 - 36	41	434	112.8	36.1	8.9 - 10.9 - 15.5	6.3 - 7.7 - 10.9	54	60	50	48	44	35			
2'	10" Inlet	150	0.025	0.024	11 - 15 - 21	8 - 10 - 15	-	71	6.2	6.0	3.2 - 4.4 - 6.2	2.2 - 3.1 - 4.4	42	35	24	15	-	-		
		270	0.088	0.078	16 - 19 - 28	11 - 14 - 20	24	127	21.9	19.4	4.8 - 5.9 - 8.4	3.4 - 4.2 - 5.9	50	47	38	33	27	13		
		330	0.131	0.117	18 - 22 - 30	12 - 15 - 22	29	156	32.7	29.0	5.4 - 6.6 - 9.3	3.8 - 4.6 - 6.6	53	51	43	39	35	22		
		390	0.183	0.163	19 - 23 - 33	14 - 17 - 23	33	184	45.6	40.6	5.8 - 7.1 - 10.1	4.1 - 5.0 - 7.1	55	54	47	44	42	29		
		510	0.313	0.279	22 - 27 - 38	15 - 19 - 27	40	241	78.1	69.4	6.7 - 8.1 - 11.5	4.7 - 5.8 - 8.1	59	60	54	52	53	41		
	4'	230	0.021	0.014	12 - 17 - 25	8 - 12 - 18	-	109	5.3	3.5	3.4 - 5.2 - 7.7	2.4 - 3.7 - 5.5	39	34	20	11	-	-		
		430	0.074	0.049	20 - 25 - 35	14 - 17 - 25	23	203	18.5	12.3	6.1 - 7.5 - 10.6	4.3 - 5.3 - 7.5	48	47	36	30	21	-		
		530	0.113	0.075	22 - 27 - 39	16 - 19 - 27	29	250	28.1	18.7	6.8 - 8.3 - 11.7	4.8 - 5.9 - 8.3	51	51	41	36	30	18		
		630	0.160	0.106	24 - 30 - 42	17 - 21 - 30	33	297	39.7	26.5	7.4 - 9.1 - 12.8	5.2 - 6.4 - 9.1	53	54	45	41	37	25		
		830	0.277	0.184	28 - 34 - 48	20 - 24 - 34	40	392	69.0	45.9	8.5 - 10.4 - 14.7	6.0 - 7.3 - 10.4	57	60	52	50	48	37		
5'	275	0.023	0.013	12 - 19 - 28	9 - 13 - 20	-	130	5.8	3.2	3.7 - 5.5 - 8.5	2.6 - 3.9 - 6.0	39	34	20	11	-	-			
	505	0.078	0.044	22 - 27 - 38	15 - 19 - 27	23	238	19.4	10.9	6.6 - 8.1 - 11.5	4.7 - 5.7 - 8.1	47	47	35	29	20	-			
	620	0.118	0.066	24 - 30 - 42	17 - 21 - 30	29	293	29.3	16.4	7.3 - 9.0 - 12.7	5.2 - 6.4 - 9.0	50	51	40	35	28	16			
	735	0.165	0.093	26 - 32 - 45	19 - 23 - 32	33	347	41.1	23.0	8.0 - 9.8 - 13.8	5.6 - 6.9 - 9.8	53	54	45	40	35	24			
	965	0.285	0.160	30 - 37 - 52	21 - 26 - 37	40	455	70.9	39.7	9.1 - 11.2 - 15.8	6.5 - 7.9 - 11.2	56	60	51	49	46	36			
2.5'	10" Inlet	180	0.030	0.018	8 - 12 - 17	6 - 9 - 12	11	85	7.4	4.5	2.5 - 3.7 - 5.3	1.8 - 2.6 - 3.7	37	36	27	22	13	-		
		310	0.088	0.053	13 - 16 - 23	9 - 11 - 16	27	146	21.9	13.2	4.0 - 4.9 - 6.9	2.8 - 3.4 - 4.9	49	48	40	37	31	18		
		375	0.129	0.078	14 - 18 - 25	10 - 12 - 18	32	177	32.1	19.3	4.4 - 5.4 - 7.6	3.1 - 3.8 - 5.4	53	53	45	42	37	25		
		440	0.177	0.107	16 - 19 - 27	11 - 14 - 19	37	208	44.1	26.6	4.7 - 5.8 - 8.2	3.4 - 4.1 - 5.8	56	56	48	46	43	30		
		570	0.297	0.179	18 - 22 - 31	13 - 15 - 22	44	269	74.1	44.6	5.4 - 6.6 - 9.3	3.8 - 4.7 - 6.6	62	62	55	53	51	40		
	4'	230	0.027	0.007	7 - 11 - 20	5 - 8 - 14	11	109	6.6	1.8	2.2 - 3.4 - 5.9	1.6 - 2.4 - 4.2	38	36	26	20	-	-		
		390	0.076	0.021	12 - 18 - 25	9 - 13 - 18	26	184	19.0	5.2	3.8 - 5.5 - 7.7	2.7 - 3.9 - 5.5	49	48	38	34	28	17		
		470	0.111	0.030	15 - 20 - 28	11 - 14 - 20	32	222	27.6	7.6	4.6 - 6.0 - 8.5	3.2 - 4.2 - 6.0	54	53	43	40	34	24		
		550	0.152	0.042	17 - 21 - 30	12 - 15 - 21	36	260	37.8	10.4	5.3 - 6.5 - 9.2	3.7 - 4.6 - 6.5	57	56	47	44	39	30		
		710	0.253	0.070	20 - 24 - 34	14 - 17 - 24	43	335	63.0	17.3	6.0 - 7.4 - 10.4	4.3 - 5.2 - 7.4	62	62	53	51	48	39		
5'	240	0.026	0.005	7 - 10 - 20	5 - 7 - 14	-	113	6.5	1.3	2.1 - 3.1 - 6.1	1.5 - 2.2 - 4.3	37	35	24	18	-	-			
	420	0.080	0.016	12 - 18 - 26	8 - 13 - 19	26	198	19.9	3.9	3.7 - 5.5 - 8.0	2.6 - 3.9 - 5.7	50	48	38	34	27	17			
	510	0.118	0.023	15 - 21 - 29	10 - 15 - 21	32	241	29.3	5.7	4.4 - 6.3 - 8.8	3.1 - 4.4 - 6.3	54	53	43	39	33	24			
	600	0.163	0.032	17 - 22 - 32	12 - 16 - 22	36	283	40.5	7.9	5.2 - 6.8 - 9.6	3.7 - 4.8 - 6.8	57	57	47	43	39	30			
	780	0.275	0.054	21 - 25 - 36	15 - 18 - 25	44	368	68.5	13.4	6.3 - 7.7 - 10.9	4.5 - 5.5 - 7.7	63	63	53	51	47	39			
2.5'	12" Inlet	210	0.030	0.024	9 - 13 - 19	7 - 9 - 13	-	99	7.5	6.1	2.9 - 4.0 - 5.7	2.0 - 2.8 - 4.0	35	34	26	20	12	-		
		360	0.089	0.071	14 - 17 - 24	10 - 12 - 17	24	170	22.1	17.8	4.3 - 5.3 - 7.4	3.0 - 3.7 - 5.3	46	46	39	35	30	14		
		435	0.130	0.104	16 - 19 - 27	11 - 13 - 19	29	205	32.3	26.0	4.7 - 5.8 - 8.2	3.3 - 4.1 - 5.8	51	51	43	41	36	21		
		510	0.178	0.143	17 - 21 - 29	12 - 15 - 21	34	241	44.4	35.7	5.1 - 6.3 - 8.8	3.6 - 4.4 - 6.3	54	54	47	45	41	26		
		660	0.299	0.240	19 - 23 - 33	14 - 17 - 23	41	311	74.4	59.8	5.8 - 7.1 - 10.1	4.1 - 5.0 - 7.1	60	60	53	52	50	36		
	4'	270	0.020	0.010	9 - 13 - 21	6 - 9 - 15	-	127	4.9	2.5	2.6 - 3.9 - 6.4	1.9 - 2.8 - 4.6	36	34	25	19	-	-		
		460	0.058	0.029	15 - 20 - 28	10 - 14 - 20	24	217	14.3	7.3	4.5 - 5.9 - 8.4	3.2 - 4.2 - 5.9	47	47	38	34	27	14		
		555	0.084	0.042	18 - 21 - 30	12 - 15 - 21	29	262	20.9	10.6	5.3 - 6.5 - 9.2	3.8 - 4.6 - 6.5	52	51	42	39	33	21		
		650	0.115	0.058	19 - 23 - 33	13 - 16 - 23	34	307	28.7	14.5	5.8 - 7.1 - 10.0	4.1 - 5.0 - 7.1	55	55	46	43	38	26		
		840	0.192	0.097	22 - 26 - 37	15 - 19 - 26	41	396	47.9	24.2	6.6 - 8.0 - 11.3	4.6 - 5.7 - 8.0	61	60	52	50	47	35		
5'	290	0.019	0.007	8 - 12 - 22	6 - 9 - 16	-	137	4.7	1.8	2.5 - 3.8 - 6.7	1.8 - 2.7 - 4.7	36	34	24	18	-	-			
	490	0.053	0.021	14 - 20 - 29	10 - 14 - 20	24	231	13.3	5.3	4.3 - 6.1 - 8.7	3.0 - 4.3 - 6.1	47	46	37	33	25	13			
	590	0.078	0.031	17 - 22 - 31	12 - 16 - 22	29	278	19.3	7.7	5.1 - 6.7 - 9.5	3.6 - 4.8 - 6.7	51	51	41	38	32	20			
	690	0.106	0.042	20 - 24 - 34	14 - 17 - 24	33	326	26.4	10.5	5.9 - 7.3 - 10.3	4.2 - 5.1 - 7.3	55	54	45	42	37	25			
	890	0.176	0.070	22 - 27 - 38	16 - 19 - 27	40	420	43.9	17.4	6.7 - 8.3 - 11.7	4.8 - 5.8 - 8.3	60	60	51	49	45	35			

LINEAR SLOT DIFFUSERS

DESIGN FLO

NOTE: See notes on page E1-24.

**DFL Performance Data: For Lay-In T-Bar (DFB) & Narrow-T (DFNT), Horizontal Throw**

IP/METRIC DATA: DFB/DFNT, 2-SLOT (HT BLADES)

Linear Length	Slot Width	Inlet	IP Data					Metric Data					Octave Band, dB							
			Air Flow	Pressure		1-Way Throw	2-Way Throw	NC	Air Flow	Pressure		1-Way Throw	2-Way Throw							
			CFM	"WG	"WG	ft	ft		L/s	Pa	Pa	m	m	2	3	4	5	6	7	
3"	2'	160	0.022	0.010	9 - 12 - 18	7 - 9 - 12	17	76	5.5	2.6	3.0 - 3.8 - 5.4	2.1 - 2.7 - 3.8	32	30	20	14	-	-		
		260	0.052	0.027	13 - 16 - 22	9 - 11 - 16	31	123	12.9	6.7	3.9 - 4.8 - 6.8	2.8 - 3.4 - 4.8	43	42	32	27	20	-		
		310	0.073	0.039	14 - 17 - 25	10 - 12 - 17	35	146	18.3	9.6	4.3 - 5.3 - 7.5	3.0 - 3.7 - 5.3	47	46	36	32	25	13		
		360	0.099	0.052	15 - 19 - 26	11 - 13 - 19	39	170	24.7	12.9	4.6 - 5.7 - 8.0	3.3 - 4.0 - 5.7	50	49	40	37	31	18		
		460	0.162	0.085	17 - 21 - 30	12 - 15 - 21	46	217	40.3	21.1	5.3 - 6.4 - 9.1	3.7 - 4.5 - 6.4	55	55	46	43	39	26		
	4'	200	0.019	0.004	8 - 13 - 20	6 - 9 - 14	17	94	4.6	1.0	2.7 - 4.0 - 6.0	1.9 - 2.8 - 4.2	33	30	19	12	-	-		
		320	0.048	0.010	13 - 18 - 25	9 - 12 - 18	30	151	11.8	2.6	4.3 - 5.4 - 7.6	3.0 - 3.8 - 5.4	43	41	31	26	18	-		
		380	0.067	0.014	16 - 19 - 27	11 - 14 - 19	35	179	16.7	3.6	4.8 - 5.8 - 8.3	3.4 - 4.1 - 5.8	47	45	35	30	23	14		
		440	0.090	0.019	17 - 21 - 29	12 - 15 - 21	39	208	22.4	4.8	5.1 - 6.3 - 8.9	3.6 - 4.4 - 6.3	50	48	39	35	28	19		
		560	0.145	0.031	19 - 23 - 33	13 - 17 - 23	45	264	36.2	7.8	5.8 - 7.1 - 10.0	4.1 - 5.0 - 7.1	56	54	45	41	36	27		
	5'	220	0.021	0.003	7 - 12 - 21	5 - 9 - 15	18	104	5.2	0.8	2.5 - 3.9 - 6.3	1.8 - 2.8 - 4.4	34	31	20	13	-	-		
		350	0.052	0.008	13 - 18 - 26	9 - 13 - 18	31	165	13.1	2.0	4.2 - 5.6 - 7.9	2.9 - 4.0 - 5.6	44	41	31	26	18	-		
415		0.074	0.011	15 - 20 - 28	11 - 14 - 20	35	196	18.3	2.7	4.9 - 6.1 - 8.6	3.5 - 4.3 - 6.1	48	45	36	30	24	15			
480		0.099	0.015	18 - 22 - 31	12 - 15 - 22	39	227	24.5	3.7	5.4 - 6.6 - 9.3	3.8 - 4.6 - 6.6	51	49	39	34	28	20			
610		0.159	0.024	20 - 24 - 34	14 - 17 - 24	46	288	39.6	5.9	6.0 - 7.4 - 10.5	4.3 - 5.2 - 7.4	56	54	45	41	36	28			
3"	2'	200	0.022	0.016	11 - 14 - 20	8 - 10 - 14	16	94	5.5	4.0	3.5 - 4.2 - 6.0	2.4 - 3.0 - 4.2	31	30	19	14	-	-		
		320	0.055	0.041	14 - 18 - 25	10 - 12 - 18	29	151	13.6	10.2	4.4 - 5.4 - 7.6	3.1 - 3.8 - 5.4	42	41	31	27	18	-		
		380	0.077	0.058	16 - 19 - 27	11 - 14 - 19	34	179	19.2	14.4	4.8 - 5.8 - 8.3	3.4 - 4.1 - 5.8	46	45	35	32	24	-		
		440	0.104	0.078	17 - 21 - 29	12 - 15 - 21	38	208	25.8	19.3	5.1 - 6.3 - 8.9	3.6 - 4.4 - 6.3	49	48	39	36	29	14		
		560	0.168	0.126	19 - 23 - 33	13 - 17 - 23	44	264	41.8	31.3	5.8 - 7.1 - 10.0	4.1 - 5.0 - 7.1	54	54	45	43	37	22		
	4'	250	0.015	0.006	10 - 16 - 22	7 - 11 - 16	16	118	3.7	1.6	3.3 - 4.7 - 6.7	2.4 - 3.4 - 4.7	32	30	19	12	-	-		
		380	0.034	0.014	16 - 19 - 27	11 - 14 - 19	28	179	8.4	3.6	4.8 - 5.8 - 8.3	3.4 - 4.1 - 5.8	41	39	29	24	15	-		
		445	0.046	0.020	17 - 21 - 29	12 - 15 - 21	32	210	11.6	4.9	5.2 - 6.3 - 8.9	3.7 - 4.5 - 6.3	45	43	33	28	21	-		
		510	0.061	0.026	18 - 22 - 32	13 - 16 - 22	36	241	15.2	6.5	5.5 - 6.8 - 9.6	3.9 - 4.8 - 6.8	48	46	37	32	25	13		
		640	0.096	0.041	20 - 25 - 35	14 - 18 - 25	42	302	23.9	10.2	6.2 - 7.6 - 10.7	4.4 - 5.4 - 7.6	53	52	42	39	33	21		
	5'	280	0.016	0.005	10 - 16 - 23	7 - 11 - 17	17	132	3.9	1.3	3.3 - 5.0 - 7.1	2.4 - 3.5 - 5.0	33	31	20	13	-	-		
		430	0.037	0.012	16 - 20 - 29	11 - 14 - 20	29	203	9.1	3.0	5.1 - 6.2 - 8.8	3.6 - 4.4 - 6.2	43	41	30	25	17	-		
505		0.051	0.016	18 - 22 - 31	13 - 16 - 22	34	238	12.6	4.1	5.5 - 6.7 - 9.5	3.9 - 4.8 - 6.7	46	44	35	30	22	11			
580		0.067	0.022	19 - 24 - 34	14 - 17 - 24	37	274	16.6	5.4	5.9 - 7.2 - 10.2	4.2 - 5.1 - 7.2	49	48	38	33	27	16			
730		0.106	0.034	22 - 27 - 38	15 - 19 - 27	44	345	26.3	8.5	6.6 - 8.1 - 11.5	4.7 - 5.7 - 8.1	54	53	44	40	34	23			

NOTES: Throw values are given for terminal velocities of 150, 100, and 50 FPM (0.75, 0.50, and 0.25 m/s). NC values are based on octave band 2-7 sound power levels minus a room absorption of 10dB, re 10<sup>-12</sup> Watts. Dash in space denotes a NC or dB value of less than 10. Data was obtained from tests conducted in accordance with ANSI/ASHRAE Standard 70, ISO Standard 5219, and ISO Standard 3741. For return applications, add 3 NC to supply data; static pressure is equal to supply total pressure. See selection software for performance data not shown, including octave band data.

LINEAR SLOT DIFFUSERS

DESIGN FLO

**DFL Performance Data: For Lay-In T-Bar (DFB) & Narrow-T (DFNT), Vertical Throw**
**IP/METRIC DATA: DFB/DFNT, 1-SLOT (VT BLADES)**

Linear Length	IP Data	Metric Data						Octave Band, dB								
		Air Flow	Pressures		Perpendicular Throw	NC	Air Flow	Pressures		Perpendicular Throw	2	3	4	5	6	7
		CFM	"WG	"WG	ft		L/s	Pa	Pa	m						
1" Slot Width 8" Inlet	2'	120	0.040	0.030	2 - 4 - 7	-	57	10.0	7.5	0.7 - 1.1 - 2.3	34	32	24	19	11	-
		230	0.147	0.111	5 - 7 - 14	25	109	36.6	27.5	1.4 - 2.2 - 4.3	49	47	40	36	30	22
		285	0.226	0.170	6 - 9 - 18	30	135	56.2	42.3	1.8 - 2.7 - 5.3	53	52	45	41	36	29
		340	0.321	0.242	7 - 10 - 19	35	160	80.0	60.2	2.1 - 3.2 - 5.9	58	56	49	46	41	35
		450	0.563	0.423	9 - 14 - 22	42	212	140.1	105.4	2.8 - 4.2 - 6.8	64	62	56	53	50	44
	4'	140	0.024	0.010	1 - 2 - 6	-	66	5.9	2.6	0.3 - 0.7 - 1.9	31	32	22	15	-	-
		270	0.088	0.038	4 - 6 - 12	24	127	22.0	9.5	1.2 - 1.8 - 3.6	46	46	37	32	25	18
		335	0.136	0.059	5 - 7 - 15	30	158	33.8	14.6	1.5 - 2.2 - 4.4	51	51	43	38	31	25
		400	0.194	0.084	6 - 9 - 17	35	189	48.2	20.8	1.8 - 2.7 - 5.3	55	55	47	42	37	31
		530	0.340	0.147	8 - 12 - 23	42	250	84.7	36.6	2.3 - 3.5 - 7.0	61	61	54	50	45	40
	5'	150	0.023	0.008	1 - 2 - 6	-	71	5.7	1.9	0.3 - 0.6 - 1.8	30	32	21	15	-	-
		290	0.086	0.028	3 - 6 - 11	25	137	21.4	7.0	1.0 - 1.7 - 3.4	45	47	37	32	24	17
		360	0.133	0.043	5 - 7 - 14	31	170	33.0	10.8	1.4 - 2.1 - 4.3	50	51	42	37	30	24
		430	0.189	0.062	6 - 8 - 17	35	203	47.1	15.4	1.7 - 2.5 - 5.1	54	55	47	42	36	30
		570	0.332	0.109	7 - 11 - 22	43	269	82.7	27.1	2.3 - 3.4 - 6.8	61	62	53	49	44	39
1" Slot Width 12" Inlet	2'	100	0.022	0.021	1 - 3 - 6	-	47	5.5	5.2	0.5 - 0.9 - 1.9	22	18	12	-	-	-
		240	0.128	0.120	5 - 7 - 15	13	113	31.9	30.0	1.5 - 2.3 - 4.5	42	38	33	29	22	11
		310	0.214	0.201	6 - 10 - 18	20	146	53.3	50.0	1.9 - 2.9 - 5.6	48	44	39	35	29	19
		380	0.321	0.302	8 - 12 - 20	25	179	80.0	75.2	2.4 - 3.6 - 6.2	53	48	44	41	35	26
		520	0.602	0.565	11 - 16 - 24	33	245	149.8	140.8	3.3 - 4.9 - 7.3	60	55	51	49	45	37
	4'	140	0.013	0.010	1 - 2 - 6	-	66	3.2	2.6	0.3 - 0.7 - 1.9	23	22	13	-	-	-
		340	0.076	0.060	5 - 7 - 15	18	160	18.9	15.0	1.5 - 2.3 - 4.5	44	42	35	30	23	13
		440	0.127	0.101	6 - 10 - 19	24	208	31.7	25.2	1.9 - 2.9 - 5.8	49	47	41	37	30	21
		540	0.192	0.152	8 - 12 - 24	30	255	47.7	38.0	2.4 - 3.6 - 7.2	54	52	46	42	36	28
		740	0.360	0.286	11 - 16 - 29	38	349	89.6	71.3	3.3 - 4.9 - 8.7	61	59	53	50	45	39
	5'	150	0.011	0.008	1 - 2 - 6	-	71	2.6	1.9	0.3 - 0.6 - 1.8	23	22	13	-	-	-
		370	0.064	0.046	5 - 7 - 14	19	175	16.0	11.4	1.5 - 2.2 - 4.4	43	42	34	30	22	13
		480	0.108	0.077	6 - 9 - 19	25	227	26.9	19.2	1.9 - 2.8 - 5.7	49	48	41	36	30	21
		590	0.163	0.116	8 - 12 - 23	31	278	40.7	29.0	2.3 - 3.5 - 7.0	54	53	46	42	36	28
		810	0.308	0.220	11 - 16 - 30	39	382	76.6	54.7	3.2 - 4.8 - 9.1	61	60	53	50	45	39
1.5" Slot Width 8" Inlet	2'	130	0.037	0.027	3 - 5 - 10	-	61	9.1	6.6	0.8 - 1.2 - 2.4	34	30	22	17	-	-
		260	0.153	0.106	7 - 10 - 17	24	123	38.1	26.5	1.6 - 2.4 - 4.9	49	46	38	34	28	19
		325	0.239	0.166	8 - 12 - 19	30	153	59.5	41.4	2.0 - 3.0 - 5.8	54	51	44	40	34	26
		390	0.344	0.239	10 - 15 - 21	35	184	85.7	59.6	2.4 - 3.7 - 6.3	58	56	48	44	39	32
		520	0.612	0.426	13 - 17 - 24	43	245	152.3	106.0	3.3 - 4.9 - 7.3	64	62	55	51	48	41
	4'	150	0.024	0.009	2 - 4 - 8	-	71	6.1	2.2	0.4 - 0.8 - 2.0	34	33	23	18	-	-
		290	0.091	0.033	5 - 8 - 15	27	137	22.6	8.2	1.3 - 1.9 - 3.8	49	48	39	35	28	21
		360	0.140	0.051	6 - 10 - 19	33	170	34.9	12.7	1.6 - 2.4 - 4.8	53	53	44	40	34	28
		430	0.200	0.073	8 - 11 - 22	37	203	49.8	18.1	1.9 - 2.9 - 5.7	57	57	48	45	39	34
		570	0.351	0.128	10 - 15 - 25	45	269	87.5	31.8	2.5 - 3.8 - 7.6	63	64	55	52	48	43
	5'	160	0.024	0.006	2 - 4 - 8	11	76	6.0	1.6	0.3 - 0.7 - 1.9	35	35	24	19	-	-
		300	0.085	0.023	5 - 7 - 14	28	142	21.1	5.6	1.0 - 1.8 - 3.6	48	49	39	35	28	22
		370	0.129	0.034	6 - 9 - 18	33	175	32.0	8.6	1.5 - 2.2 - 4.4	53	54	44	40	34	29
		440	0.182	0.049	7 - 11 - 21	38	208	45.3	12.1	1.7 - 2.6 - 5.2	57	58	48	44	39	35
		580	0.316	0.085	9 - 14 - 25	46	274	78.7	21.1	2.3 - 3.4 - 6.9	63	64	55	51	47	44
1.5" Slot Width 12" Inlet	2'	160	0.042	0.040	4 - 6 - 12	-	76	10.4	10.0	1.0 - 1.5 - 3.0	28	21	14	-	-	-
		360	0.221	0.204	9 - 14 - 20	14	170	55.1	50.8	2.3 - 3.4 - 6.1	45	39	33	28	21	-
		460	0.361	0.333	12 - 16 - 23	21	217	90.0	82.9	2.9 - 4.3 - 6.8	51	45	39	34	28	16
		560	0.536	0.494	14 - 18 - 25	26	264	133.4	122.9	3.5 - 5.3 - 7.6	55	49	44	39	33	22
		760	0.987	0.909	17 - 20 - 29	34	359	245.7	226.3	4.8 - 6.2 - 8.8	61	56	51	46	42	32
	4'	240	0.030	0.023	4 - 6 - 13	-	113	7.6	5.6	0.9 - 1.6 - 3.2	34	29	21	15	-	-
		440	0.102	0.076	8 - 12 - 22	20	208	25.4	19.0	1.9 - 2.9 - 5.8	47	43	36	31	24	13
		540	0.154	0.115	10 - 14 - 24	25	255	38.3	28.6	2.4 - 3.6 - 7.2	51	48	40	36	29	20
		640	0.216	0.161	11 - 17 - 27	30	302	53.8	40.1	2.8 - 4.2 - 8.1	55	52	44	40	34	25
		840	0.372	0.278	15 - 22 - 30	37	396	92.7	69.1	3.7 - 5.6 - 9.3	61	58	51	47	42	34
	5'	250	0.024	0.016	4 - 6 - 12	-	118	6.0	3.9	0.7 - 1.5 - 3.0	34	30	21	16	-	-
		450	0.078	0.051	7 - 11 - 22	20	212	19.5	12.7	1.8 - 2.7 - 5.3	46	44	35	31	23	14
		550	0.117	0.076	9 - 13 - 25	26	260	29.1	19.0	2.2 - 3.3 - 6.5	51	48	40	36	29	20
		650	0.163	0.106	10 - 16 - 27	30	307	40.6	26.5	2.6 - 3.9 - 7.7	54	52	44	40	34	25
		850	0.279	0.182	14 - 20 - 31	37	401	69.5	45.3	3.4 - 5.0 - 9.3	60	58	50	46	42	34

NOTE: See notes on page E1-27.



**DFL Performance Data: For Lay-In T-Bar (DFB) & Narrow-T (DFNT), Vertical Throw**

IP/METRIC DATA: DFB/DFNT, 1-SLOT (VT BLADES)

	Linear Length	IP Data					NC	Metric Data				Octave Band, dB						
		Air Flow	Pressures		Perpendicular Throw	Air Flow		Pressures		Perpendicular Throw								
		CFM	"WG	"WG	ft	L/s		Pa	Pa	m	2	3	4	5	6	7		
2" Slot Width 8" Inlet	2'	140	0.031	0.021	4 - 6 - 12	-	66	7.8	5.3	0.9 - 1.3 - 2.6	36	31	18	13	-	-		
		270	0.130	0.080	8 - 12 - 17	24	127	32.3	19.8	1.7 - 2.5 - 5.1	51	46	35	32	26	18		
		335	0.200	0.122	10 - 14 - 19	30	158	49.7	30.5	2.1 - 3.1 - 5.8	56	52	41	38	33	26		
		400	0.285	0.175	12 - 15 - 21	35	189	70.9	43.5	2.5 - 3.8 - 6.4	60	56	46	43	39	33		
		530	0.500	0.306	14 - 17 - 24	43	250	124.4	76.3	3.3 - 5.0 - 7.4	66	63	53	51	49	43		
	4'	160	0.025	0.007	3 - 5 - 10	-	76	6.1	1.7	0.4 - 0.9 - 2.1	31	28	16	11	-	-		
		320	0.098	0.028	7 - 10 - 19	23	151	24.5	7.0	1.4 - 2.1 - 4.2	46	45	34	30	24	16		
		400	0.154	0.044	8 - 12 - 21	29	189	38.3	10.9	1.8 - 2.7 - 5.3	51	50	40	37	32	24		
		480	0.221	0.063	10 - 15 - 23	34	227	55.1	15.6	2.1 - 3.2 - 6.4	56	54	45	42	38	31		
		640	0.394	0.112	13 - 19 - 27	42	302	98.0	27.8	2.8 - 4.2 - 8.1	62	61	53	50	47	41		
	5'	170	0.025	0.005	3 - 5 - 9	-	80	6.2	1.3	0.3 - 0.7 - 2.0	30	28	15	-	-	-		
		350	0.106	0.021	6 - 10 - 19	23	165	26.3	5.3	1.4 - 2.1 - 4.2	46	45	35	31	24	16		
		440	0.167	0.034	8 - 12 - 22	29	208	41.6	8.4	1.7 - 2.6 - 5.2	51	50	41	37	32	25		
		530	0.242	0.049	10 - 15 - 24	35	250	60.3	12.2	2.1 - 3.1 - 6.3	55	55	46	43	39	31		
		710	0.435	0.088	13 - 20 - 28	43	335	108.3	21.9	2.8 - 4.2 - 8.4	62	62	54	51	48	42		
2" Slot Width 12" Inlet	2'	140	0.023	0.021	4 - 6 - 12	-	66	5.7	5.3	0.9 - 1.3 - 2.6	31	22	-	-	-	-		
		320	0.125	0.112	9 - 13 - 19	17	151	31.2	27.8	2.0 - 3.0 - 5.7	50	41	28	25	17	-		
		410	0.206	0.183	12 - 15 - 21	24	193	51.3	45.7	2.6 - 3.8 - 6.5	55	47	35	32	25	18		
		500	0.306	0.273	14 - 17 - 23	29	236	76.3	67.9	3.1 - 4.7 - 7.1	60	52	40	38	32	25		
		680	0.567	0.504	16 - 19 - 27	38	321	141.1	125.6	4.3 - 5.9 - 8.3	67	59	48	46	42	37		
	4'	220	0.020	0.013	5 - 7 - 14	-	104	4.9	3.3	0.8 - 1.5 - 2.9	33	27	12	-	-	-		
		440	0.079	0.053	9 - 14 - 22	20	208	19.6	13.1	1.9 - 2.9 - 5.8	49	43	31	27	20	11		
		550	0.123	0.083	11 - 17 - 25	26	260	30.7	20.5	2.4 - 3.6 - 7.3	54	49	37	34	27	20		
		660	0.177	0.119	14 - 19 - 27	31	311	44.2	29.6	2.9 - 4.4 - 8.2	58	53	42	39	34	26		
		880	0.315	0.211	18 - 22 - 31	39	415	78.5	52.6	3.9 - 5.8 - 9.5	64	60	50	47	43	37		
	5'	220	0.015	0.008	4 - 6 - 12	-	104	3.7	2.1	0.6 - 1.3 - 2.6	30	25	11	-	-	-		
		460	0.065	0.037	8 - 13 - 23	19	217	16.3	9.2	1.8 - 2.7 - 5.5	47	42	30	27	19	-		
		580	0.104	0.059	11 - 16 - 25	25	274	25.9	14.6	2.3 - 3.4 - 6.9	52	48	37	33	27	19		
		700	0.151	0.086	13 - 19 - 28	31	330	37.7	21.3	2.8 - 4.2 - 8.3	56	52	42	39	33	26		
		940	0.273	0.154	17 - 23 - 32	39	444	68.0	38.4	3.7 - 5.6 - 9.8	63	59	50	47	43	37		
2.5" Slot Width 10" Inlet	2'	160	0.031	0.022	5 - 8 - 13	-	76	7.7	5.4	1.6 - 2.4 - 4.0	36	31	20	15	-	-		
		360	0.157	0.110	12 - 14 - 20	26	170	39.2	27.4	3.5 - 4.3 - 6.1	52	48	39	35	30	20		
		460	0.257	0.180	13 - 16 - 23	32	217	64.0	44.8	4.0 - 4.8 - 6.8	57	53	44	41	37	27		
		560	0.381	0.267	14 - 18 - 25	36	264	94.8	66.4	4.4 - 5.3 - 7.6	61	57	49	46	43	33		
		760	0.701	0.491	17 - 20 - 29	44	359	174.6	122.3	5.1 - 6.2 - 8.8	68	63	56	53	51	43		
	4'	180	0.019	0.007	4 - 6 - 12	-	85	4.6	1.7	1.3 - 1.9 - 3.8	34	32	21	16	-	-		
		390	0.088	0.032	9 - 13 - 21	26	184	21.8	8.0	2.7 - 4.1 - 6.3	50	48	39	35	30	20		
		495	0.141	0.052	11 - 17 - 23	32	234	35.2	13.0	3.5 - 5.0 - 7.1	55	53	44	40	37	27		
		600	0.207	0.077	14 - 18 - 26	37	283	51.7	19.1	4.2 - 5.5 - 7.8	59	57	49	45	42	33		
		810	0.378	0.139	17 - 21 - 30	44	382	94.1	34.7	5.2 - 6.4 - 9.1	65	63	56	52	50	42		
	5'	190	0.018	0.005	4 - 6 - 12	-	90	4.5	1.2	1.2 - 1.8 - 3.6	34	33	22	16	-	-		
		410	0.084	0.023	8 - 13 - 21	27	193	20.9	5.7	2.6 - 3.8 - 6.5	50	48	40	35	30	20		
		520	0.135	0.037	11 - 16 - 24	33	245	33.6	9.2	3.3 - 4.9 - 7.3	54	53	45	41	37	28		
		630	0.198	0.054	13 - 19 - 26	37	297	49.4	13.4	3.9 - 5.7 - 8.0	58	57	49	45	42	34		
		850	0.361	0.098	17 - 22 - 31	44	401	89.9	24.5	5.3 - 6.6 - 9.3	64	63	56	53	51	43		
2.5" Slot Width 12" Inlet	2'	170	0.028	0.025	6 - 8 - 14	-	80	7.1	6.1	1.7 - 2.5 - 4.2	32	25	14	-	-	-		
		420	0.174	0.150	12 - 15 - 22	21	198	43.2	37.3	3.8 - 4.6 - 6.5	50	44	34	31	25	13		
		545	0.292	0.253	14 - 17 - 25	27	257	72.8	62.9	4.3 - 5.3 - 7.5	56	49	40	37	32	21		
		670	0.442	0.382	16 - 19 - 27	32	316	110.1	95.0	4.8 - 5.8 - 8.3	60	53	45	42	38	28		
		920	0.833	0.720	18 - 23 - 32	39	434	207.5	179.2	5.6 - 6.8 - 9.7	66	60	52	50	47	37		
	4'	200	0.014	0.009	5 - 7 - 14	-	94	3.5	2.1	1.4 - 2.1 - 4.2	31	27	16	-	-	-		
		470	0.077	0.047	11 - 16 - 23	22	222	19.1	11.7	3.3 - 4.9 - 6.9	49	45	35	31	25	14		
		605	0.127	0.078	14 - 18 - 26	28	286	31.6	19.4	4.2 - 5.6 - 7.9	54	50	41	37	32	22		
		740	0.190	0.116	16 - 20 - 29	33	349	47.3	29.0	5.0 - 6.1 - 8.7	58	54	46	42	38	28		
		1010	0.354	0.217	19 - 24 - 33	40	477	88.1	54.0	5.9 - 7.2 - 10.1	64	60	53	50	47	38		
	5'	210	0.012	0.006	4 - 6 - 13	-	99	3.0	1.5	1.3 - 2.0 - 3.9	31	28	16	11	-	-		
		490	0.065	0.033	10 - 15 - 23	22	231	16.2	8.1	3.1 - 4.6 - 7.1	48	45	36	31	26	14		
		630	0.107	0.054	13 - 19 - 26	28	297	26.7	13.4	3.9 - 5.7 - 8.0	53	50	41	37	33	22		
		770	0.160	0.081	16 - 21 - 29	33	363	39.9	20.1	4.8 - 6.3 - 8.9	57	54	46	42	38	28		
		1050	0.298	0.150	20 - 24 - 34	41	496	74.2	37.3	6.0 - 7.3 - 10.3	64	61	53	50	47	38		

NOTE: See notes on page E1-27.

LINEAR SLOT DIFFUSERS

DESIGN FLO

© KRUEGER 2012

**DFL Performance Data: For Lay-In T-Bar (DFB) & Narrow-T (DFNT), Vertical Throw**
**IP/METRIC DATA: DFB/DFNT, 1-SLOT (VT BLADES)**

	Linear Length	IP Data				NC	Metric Data				Octave Band, dB						
		Air Flow	Pressures		Perpendicular Throw		Air Flow	Pressures		Perpendicular Throw	2	3	4	5	6	7	
		CFM	"WG	"WG	ft		L/s	Pa	Pa	m							
3" Slot Width 10" Inlet	2'	170	0.028	0.019	6 - 9 - 14	-	80	7.0	4.7	1.7 - 2.5 - 4.2	36	32	21	16	-	-	
		370	0.138	0.089	12 - 14 - 20	26	175	34.5	22.1	3.5 - 4.3 - 6.1	52	48	39	35	30	19	
		470	0.223	0.143	13 - 16 - 23	32	222	55.6	35.6	4.0 - 4.9 - 6.9	57	53	45	40	36	26	
		570	0.329	0.210	14 - 18 - 25	37	269	81.8	52.4	4.4 - 5.4 - 7.6	60	57	49	45	42	32	
	770	0.600	0.384	17 - 21 - 29	44	363	149.3	95.6	5.1 - 6.3 - 8.9	67	63	56	52	50	42		
	4'	190	0.019	0.006	5 - 7 - 14	-	90	4.7	1.5	1.3 - 2.0 - 4.0	35	33	22	15	-	-	
		400	0.084	0.026	10 - 15 - 21	27	189	20.9	6.5	2.8 - 4.2 - 6.4	50	48	39	33	28	19	
		505	0.134	0.041	13 - 17 - 24	32	238	33.4	10.3	3.5 - 5.1 - 7.2	55	53	44	39	35	26	
		610	0.196	0.060	15 - 18 - 26	37	288	48.7	15.0	4.3 - 5.6 - 7.9	59	57	48	44	41	32	
	820	0.353	0.109	17 - 21 - 30	44	387	88.0	27.1	5.3 - 6.5 - 9.1	65	63	55	51	49	41		
	5'	200	0.019	0.004	5 - 7 - 14	-	94	4.7	1.0	1.3 - 1.9 - 3.8	35	33	22	16	-	-	
		420	0.082	0.018	9 - 14 - 22	27	198	20.5	4.6	2.6 - 3.9 - 6.5	50	49	39	34	29	19	
530		0.131	0.029	12 - 17 - 24	33	250	32.7	7.2	3.3 - 5.0 - 7.4	55	53	44	39	35	27		
640		0.191	0.042	14 - 19 - 27	37	302	47.7	10.6	4.0 - 5.7 - 8.1	58	57	49	44	41	33		
860	0.346	0.077	18 - 22 - 31	45	406	86.1	19.1	5.4 - 6.6 - 9.4	64	64	55	51	49	42			
3" Slot Width 12" Inlet	2'	180	0.025	0.021	6 - 10 - 14	-	85	6.2	5.2	1.8 - 2.7 - 4.3	31	26	15	-	-	-	
		430	0.145	0.120	13 - 15 - 22	22	203	36.0	29.8	3.8 - 4.7 - 6.6	49	44	35	31	24	12	
		555	0.241	0.199	14 - 17 - 25	28	262	60.0	49.7	4.3 - 5.3 - 7.5	54	50	41	37	31	20	
		680	0.362	0.299	16 - 19 - 27	33	321	90.0	74.6	4.8 - 5.9 - 8.3	59	54	46	42	37	26	
	930	0.676	0.560	18 - 23 - 32	40	439	168.4	139.5	5.6 - 6.9 - 9.7	65	60	53	49	46	36		
	4'	210	0.013	0.007	5 - 8 - 15	-	99	3.3	1.8	1.5 - 2.2 - 4.4	31	28	16	-	-	-	
		490	0.071	0.039	12 - 16 - 23	23	231	17.7	9.7	3.4 - 5.0 - 7.1	48	45	36	31	25	13	
		630	0.118	0.064	15 - 19 - 26	29	297	29.3	16.0	4.4 - 5.7 - 8.0	54	51	42	37	32	21	
		770	0.176	0.096	17 - 21 - 29	34	363	43.7	23.9	5.1 - 6.3 - 8.9	58	55	46	42	37	28	
	1050	0.327	0.178	20 - 24 - 34	41	496	81.3	44.4	6.0 - 7.3 - 10.3	64	61	53	49	46	37		
	5'	230	0.013	0.005	5 - 8 - 16	-	109	3.1	1.4	1.4 - 2.2 - 4.3	32	29	18	11	-	-	
		510	0.062	0.027	11 - 17 - 24	23	241	15.4	6.7	3.2 - 4.8 - 7.2	48	46	36	31	25	14	
650		0.101	0.044	15 - 19 - 27	29	307	25.0	10.9	4.1 - 5.8 - 8.1	53	51	42	36	32	21		
790		0.149	0.065	17 - 21 - 30	34	373	37.0	16.1	4.9 - 6.3 - 9.0	57	55	46	41	37	28		
1070	0.273	0.119	20 - 24 - 34	41	505	67.9	29.5	6.0 - 7.4 - 10.4	63	61	53	49	46	37			

NOTES: Throw values are given for terminal velocities of 150, 100, and 50 FPM (0.75, 0.50, and 0.25 m/s). NC values are based on octave band 2 - 7 sound power levels minus a room absorption of 10dB, re 10<sup>-12</sup> Watts. Dash in space denotes a NC or dB value of less than 10. Data was obtained from tests conducted in accordance with ANSI/ASHRAE Standard 70, ISO Standard 5219, and ISO Standard 3741. For return applications, add 3 NC to supply data; static pressure is equal to supply total pressure. See selection software for performance data not shown, including octave band data.

**DFL Performance Data: For Lay-In T-Bar (DFB) & Narrow-T (DFNT), Vertical Throw**

IP/METRIC DATA: DFB/DFNT, 2-SLOT (VT BLADES)

	Linear Length	IP Data					NC	Metric Data				Octave Band, dB						
		Air Flow	Pressures		Perpendicular Throw	Air Flow		Pressures		Perpendicular Throw	2	3	4	5	6	7		
			"WG	"WG				L/s	Pa								Pa	m
		CFM	"WG	"WG	ft	L/s		Pa	Pa	m	2	3	4	5	6	7		
1" Slot Width 10" Inlet	2'	160	0.023	0.013	1 - 3 - 7	-	76	5.7	3.3	0.4 - 0.9 - 2.1	31	31	21	16	-	-		
		310	0.085	0.050	5 - 7 - 14	23	146	21.2	12.5	1.4 - 2.1 - 4.1	46	46	37	33	26	17		
		385	0.131	0.077	6 - 8 - 17	29	182	32.7	19.3	1.7 - 2.6 - 5.1	51	50	43	38	32	25		
		460	0.188	0.111	7 - 10 - 20	34	217	46.7	27.5	2.0 - 3.0 - 6.1	55	54	47	43	37	30		
		610	0.330	0.195	9 - 13 - 26	41	288	82.1	48.4	2.7 - 4.0 - 7.9	62	61	54	50	45	40		
	4'	180	0.016	0.004	1 - 1 - 5	-	85	4.0	1.1	0.2 - 0.4 - 1.7	27	29	18	11	-	-		
		380	0.071	0.019	3 - 6 - 12	24	179	17.8	4.7	0.8 - 1.8 - 3.6	44	46	36	30	22	15		
		480	0.114	0.030	4 - 7 - 15	30	227	28.4	7.5	1.3 - 2.3 - 4.5	49	51	41	36	29	22		
		580	0.166	0.044	6 - 9 - 18	35	274	41.4	10.9	1.8 - 2.7 - 5.4	54	55	46	41	34	29		
		780	0.301	0.080	8 - 12 - 24	43	368	74.9	19.8	2.4 - 3.7 - 7.3	61	62	53	49	43	38		
	5'	190	0.016	0.003	0 - 1 - 4	-	90	4.0	0.8	0.1 - 0.3 - 1.3	26	29	17	-	-	-		
		400	0.072	0.013	2 - 5 - 11	24	189	17.8	3.3	0.6 - 1.5 - 3.4	43	46	35	29	20	13		
		505	0.114	0.021	3 - 7 - 14	30	238	28.4	5.3	1.0 - 2.1 - 4.2	49	51	41	35	27	21		
		610	0.166	0.031	5 - 8 - 17	35	288	41.5	7.7	1.5 - 2.6 - 5.1	53	55	45	40	33	27		
		820	0.301	0.056	8 - 11 - 23	43	387	74.9	14.0	2.3 - 3.4 - 6.9	60	62	52	47	42	37		
1" Slot Width 12" Inlet	2'	170	0.019	0.015	2 - 3 - 7	-	80	4.7	3.8	0.5 - 1.0 - 2.3	28	26	18	12	-	-		
		370	0.090	0.072	5 - 8 - 16	20	175	22.4	17.8	1.6 - 2.5 - 4.9	45	44	37	32	25	16		
		470	0.145	0.115	7 - 10 - 20	26	222	36.1	28.8	2.1 - 3.1 - 6.2	51	49	42	38	32	24		
		570	0.214	0.170	8 - 12 - 25	31	269	53.2	42.3	2.5 - 3.8 - 7.6	55	53	47	43	38	30		
		770	0.390	0.310	11 - 17 - 29	39	363	97.0	77.2	3.4 - 5.1 - 8.9	62	60	54	51	47	40		
	4'	190	0.010	0.005	1 - 2 - 6	-	90	2.4	1.2	0.2 - 0.5 - 1.8	24	24	14	-	-	-		
		440	0.051	0.025	4 - 7 - 14	20	208	12.8	6.3	1.1 - 2.1 - 4.1	43	43	34	29	21	12		
		565	0.085	0.042	6 - 9 - 17	27	267	21.1	10.4	1.8 - 2.6 - 5.3	49	49	40	35	28	20		
		690	0.126	0.062	7 - 11 - 21	32	326	31.4	15.5	2.2 - 3.2 - 6.5	53	53	45	40	34	27		
		940	0.234	0.115	10 - 14 - 29	40	444	58.3	28.8	2.9 - 4.4 - 8.8	60	60	53	48	43	37		
	5'	200	0.009	0.003	1 - 1 - 5	-	94	2.2	0.8	0.2 - 0.4 - 1.5	23	24	13	-	-	-		
		460	0.046	0.018	3 - 6 - 13	20	217	11.5	4.4	0.9 - 1.9 - 3.9	42	43	33	28	19	-		
		590	0.076	0.029	5 - 8 - 16	26	278	18.9	7.2	1.4 - 2.5 - 4.9	48	48	39	34	26	19		
		720	0.113	0.043	7 - 10 - 20	32	340	28.1	10.8	2.0 - 3.0 - 6.0	52	53	44	39	32	25		
		980	0.209	0.080	9 - 14 - 27	40	463	52.1	20.0	2.7 - 4.1 - 8.2	59	60	51	47	41	35		
1.5" Slot Width 10" Inlet	2'	170	0.021	0.011	3 - 5 - 9	-	80	5.1	2.8	0.5 - 1.0 - 2.3	33	30	21	16	-	-		
		370	0.104	0.054	7 - 10 - 20	26	175	25.8	13.4	1.6 - 2.5 - 4.9	50	48	39	35	29	21		
		470	0.167	0.087	8 - 13 - 23	33	222	41.6	21.6	2.1 - 3.1 - 6.2	55	54	45	41	36	29		
		570	0.246	0.128	10 - 15 - 25	38	269	61.3	31.8	2.5 - 3.8 - 7.6	59	58	50	46	41	35		
		770	0.449	0.233	14 - 21 - 29	46	363	111.8	58.1	3.4 - 5.1 - 8.9	65	65	57	53	50	45		
	4'	190	0.017	0.004	1 - 3 - 7	-	90	4.2	0.9	0.2 - 0.5 - 1.8	32	32	21	16	-	-		
		390	0.070	0.015	5 - 7 - 15	28	184	17.5	3.7	0.9 - 1.8 - 3.7	48	49	38	34	28	21		
		490	0.111	0.024	6 - 9 - 19	34	231	27.6	5.9	1.4 - 2.3 - 4.6	53	54	44	40	34	29		
		590	0.161	0.034	7 - 11 - 22	39	278	40.1	8.5	1.8 - 2.8 - 5.5	57	58	48	45	39	35		
		790	0.288	0.061	10 - 15 - 30	47	373	71.8	15.3	2.5 - 3.7 - 7.4	63	65	55	52	48	44		
	5'	200	0.017	0.003	1 - 2 - 7	-	94	4.2	0.6	0.2 - 0.4 - 1.5	33	33	22	17	-	-		
		410	0.072	0.011	4 - 7 - 14	29	193	17.9	2.6	0.7 - 1.5 - 3.4	48	50	39	35	28	23		
		515	0.113	0.017	6 - 9 - 17	35	243	28.2	4.2	1.1 - 2.2 - 4.3	53	55	44	41	35	30		
		620	0.164	0.024	7 - 10 - 21	40	293	40.8	6.0	1.6 - 2.6 - 5.2	57	59	49	45	40	36		
		830	0.294	0.043	9 - 14 - 28	48	392	73.2	10.8	2.3 - 3.5 - 7.0	63	66	56	53	48	46		
1.5" Slot Width 12" Inlet	2'	180	0.017	0.013	3 - 5 - 10	-	85	4.1	3.2	0.5 - 1.2 - 2.4	28	23	14	-	-	-		
		420	0.093	0.069	7 - 11 - 22	18	198	23.2	17.3	1.9 - 2.8 - 5.6	46	42	34	29	22	12		
		540	0.154	0.115	10 - 14 - 24	25	255	38.3	28.6	2.4 - 3.6 - 7.2	51	48	40	36	29	20		
		660	0.230	0.171	12 - 18 - 27	31	311	57.3	42.7	2.9 - 4.4 - 8.2	56	53	45	41	35	26		
		900	0.428	0.319	16 - 22 - 32	39	425	106.5	79.4	4.0 - 6.0 - 9.6	62	60	53	49	44	36		
	4'	200	0.009	0.004	1 - 3 - 8	-	94	2.3	1.0	0.2 - 0.5 - 1.9	27	25	15	-	-	-		
		460	0.049	0.021	6 - 9 - 17	21	217	12.3	5.2	1.2 - 2.2 - 4.3	45	44	34	30	22	14		
		590	0.081	0.034	7 - 11 - 22	28	278	20.2	8.5	1.8 - 2.8 - 5.5	50	49	40	36	29	22		
		720	0.121	0.051	9 - 14 - 27	33	340	30.0	12.7	2.3 - 3.4 - 6.8	55	54	45	41	35	28		
		980	0.224	0.094	12 - 19 - 33	41	463	55.7	23.5	3.1 - 4.6 - 9.2	61	61	52	49	44	38		
	5'	210	0.009	0.003	1 - 2 - 7	-	99	2.2	0.7	0.2 - 0.4 - 1.6	27	26	15	-	-	-		
		480	0.045	0.015	5 - 8 - 16	22	227	11.3	3.6	0.9 - 2.0 - 4.0	45	45	35	30	22	15		
		615	0.075	0.024	7 - 10 - 21	29	290	18.6	5.9	1.5 - 2.6 - 5.2	50	50	40	36	30	23		
		750	0.111	0.035	8 - 13 - 25	34	354	27.6	8.8	2.1 - 3.1 - 6.3	55	55	45	41	35	29		
		1020	0.205	0.065	11 - 17 - 34	42	481	51.1	16.3	2.9 - 4.3 - 8.6	61	62	52	49	44	39		

NOTE: See notes on page E1-30.

LINEAR SLOT DIFFUSERS

DESIGN FLO

**DFL Performance Data: For Lay-In T-Bar (DFB) & Narrow-T (DFNT), Vertical Throw**

IP/METRIC DATA: DFB/DFNT, 2-SLOT (VT BLADES)

Linear Length	IP Data	Metric Data						Octave Band, dB								
		Air Flow	Pressures		Perpendicular Throw	NC	Air Flow	Pressures		Perpendicular Throw	2	3	4	5	6	7
		CFM	"WG	"WG	ft		L/s	Pa	Pa	m						
2" Slot Width 10" Inlet	2'	180	0.018	0.009	4 - 6 - 11	-	85	4.5	2.2	0.5 - 1.2 - 2.4	32	27	14	-	-	-
		380	0.092	0.039	8 - 12 - 20	23	179	22.9	9.8	1.7 - 2.5 - 5.0	48	45	34	31	24	16
		480	0.147	0.063	10 - 15 - 23	29	227	36.5	15.6	2.1 - 3.2 - 6.4	54	51	41	37	32	24
		580	0.214	0.092	12 - 18 - 25	35	274	53.3	22.8	2.6 - 3.8 - 7.7	58	55	46	43	38	31
	780	0.387	0.166	16 - 21 - 29	43	368	96.4	41.3	3.4 - 5.2 - 8.9	64	62	54	51	48	42	
	4'	200	0.017	0.003	2 - 4 - 9	-	94	4.3	0.7	0.2 - 0.5 - 1.9	26	24	11	-	-	-
		470	0.095	0.015	7 - 10 - 20	22	222	23.8	3.8	1.3 - 2.2 - 4.4	45	44	34	30	23	15
		605	0.158	0.025	9 - 13 - 26	29	286	39.4	6.2	1.9 - 2.8 - 5.7	50	50	41	37	32	24
		740	0.237	0.037	11 - 16 - 29	35	349	58.9	9.3	2.3 - 3.5 - 6.9	55	55	47	43	39	31
	1010	0.441	0.070	15 - 22 - 33	44	477	109.7	17.3	3.2 - 4.7 - 9.5	62	63	55	52	49	43	
	5'	210	0.018	0.002	2 - 4 - 8	-	99	4.5	0.5	0.2 - 0.4 - 1.6	24	23	11	-	-	-
		500	0.102	0.011	7 - 10 - 20	22	236	25.4	2.7	1.0 - 2.1 - 4.2	44	44	34	30	23	14
645		0.169	0.018	8 - 13 - 25	29	304	42.2	4.5	1.7 - 2.7 - 5.4	49	50	41	37	32	23	
790		0.254	0.027	10 - 15 - 30	35	373	63.3	6.8	2.2 - 3.3 - 6.6	54	55	46	43	38	31	
1080	0.475	0.051	14 - 21 - 35	44	510	118.3	12.7	3.0 - 4.5 - 9.1	61	62	55	52	49	43		
2" Slot Width 12" Inlet	2'	190	0.014	0.010	4 - 6 - 12	-	90	3.4	2.5	0.6 - 1.3 - 2.5	30	23	-	-	-	-
		430	0.075	0.050	9 - 13 - 22	19	203	18.7	12.6	1.9 - 2.9 - 5.7	48	43	30	27	19	11
		550	0.123	0.083	11 - 17 - 25	26	260	30.7	20.5	2.4 - 3.6 - 7.3	54	49	37	34	27	20
		670	0.183	0.122	14 - 19 - 27	31	316	45.5	30.5	3.0 - 4.4 - 8.3	58	53	42	39	34	27
	910	0.337	0.226	18 - 22 - 32	40	429	84.0	56.2	4.0 - 6.0 - 9.6	65	61	51	48	44	38	
	4'	210	0.009	0.003	2 - 5 - 9	-	99	2.2	0.7	0.3 - 0.6 - 2.0	24	20	-	-	-	-
		520	0.055	0.018	8 - 11 - 23	18	245	13.6	4.6	1.5 - 2.4 - 4.9	44	41	30	26	18	-
		675	0.092	0.031	10 - 15 - 27	25	319	23.0	7.7	2.1 - 3.2 - 6.3	50	48	37	33	27	18
		830	0.140	0.047	12 - 18 - 30	31	392	34.8	11.7	2.6 - 3.9 - 7.8	54	53	42	39	34	26
	1140	0.263	0.089	17 - 25 - 35	40	538	65.6	22.1	3.6 - 5.3 - 10.7	62	60	51	48	44	38	
	5'	220	0.009	0.002	2 - 4 - 9	-	104	2.1	0.5	0.2 - 0.4 - 1.8	22	19	-	-	-	-
		560	0.056	0.014	7 - 11 - 22	18	264	13.9	3.4	1.3 - 2.3 - 4.7	43	41	30	26	18	-
730		0.095	0.023	9 - 14 - 28	25	345	23.6	5.8	2.0 - 3.1 - 6.1	49	48	37	33	27	18	
900		0.144	0.035	12 - 18 - 32	31	425	35.9	8.8	2.5 - 3.8 - 7.5	54	53	43	39	34	26	
1240	0.274	0.067	16 - 24 - 37	40	585	68.2	16.7	3.5 - 5.2 - 10.4	61	60	51	48	45	38		
2.5" Slot Width 10" Inlet	2'	200	0.023	0.009	5 - 7 - 14	-	94	5.7	2.1	1.4 - 2.1 - 4.2	36	34	24	18	11	-
		400	0.092	0.034	9 - 14 - 21	27	189	23.0	8.5	2.8 - 4.2 - 6.4	50	48	40	35	31	20
		500	0.144	0.053	11 - 17 - 23	32	236	35.9	13.2	3.5 - 5.0 - 7.1	55	53	45	41	37	27
		600	0.207	0.077	14 - 18 - 26	37	283	51.7	19.1	4.2 - 5.5 - 7.8	59	57	49	45	42	33
	800	0.369	0.136	17 - 21 - 30	43	378	91.8	33.9	5.2 - 6.4 - 9.0	65	63	55	52	50	42	
	4'	220	0.020	0.003	4 - 5 - 11	11	104	5.0	0.6	1.1 - 1.6 - 3.3	34	35	24	18	11	-
		440	0.081	0.010	7 - 11 - 21	28	208	20.1	2.6	2.2 - 3.3 - 6.5	48	49	40	35	30	21
		550	0.126	0.016	9 - 13 - 25	33	260	31.4	4.0	2.7 - 4.1 - 7.5	53	54	45	40	37	28
		660	0.182	0.023	11 - 16 - 27	37	311	45.2	5.8	3.3 - 4.9 - 8.2	57	57	49	45	42	33
	880	0.323	0.041	14 - 21 - 31	44	415	80.4	10.2	4.3 - 6.5 - 9.5	62	63	56	52	50	42	
	5'	230	0.021	0.002	3 - 5 - 10	12	109	5.2	0.4	0.8 - 1.5 - 3.0	34	35	25	18	11	-
		450	0.081	0.007	7 - 10 - 20	28	212	20.1	1.7	2.0 - 3.0 - 6.0	47	49	40	35	30	21
560		0.125	0.011	8 - 12 - 24	33	264	31.1	2.7	2.5 - 3.7 - 7.4	52	54	45	40	36	27	
670		0.179	0.015	10 - 15 - 27	37	316	44.5	3.8	3.0 - 4.4 - 8.3	56	57	49	44	41	33	
890	0.315	0.027	13 - 19 - 31	44	420	78.4	6.7	3.9 - 5.9 - 9.5	61	63	56	51	49	42		
2.5" Slot Width 12" Inlet	2'	220	0.017	0.010	5 - 8 - 15	-	104	4.2	2.6	1.5 - 2.3 - 4.6	33	29	18	12	-	-
		480	0.080	0.049	11 - 16 - 23	22	227	19.9	12.2	3.4 - 4.9 - 7.0	49	45	36	31	26	15
		610	0.129	0.079	14 - 18 - 26	28	288	32.1	19.7	4.3 - 5.6 - 7.9	54	50	41	37	33	22
		740	0.190	0.116	16 - 20 - 29	33	349	47.3	29.0	5.0 - 6.1 - 8.7	58	54	46	42	38	28
	1000	0.347	0.213	19 - 23 - 33	40	472	86.4	52.9	5.8 - 7.1 - 10.1	64	60	52	49	46	37	
	4'	240	0.011	0.003	4 - 6 - 12	-	113	2.7	0.8	1.2 - 1.8 - 3.6	31	29	18	12	-	-
		520	0.051	0.014	8 - 13 - 24	23	245	12.6	3.6	2.6 - 3.9 - 7.3	47	45	36	31	25	15
		660	0.082	0.023	11 - 16 - 27	29	311	20.3	5.8	3.3 - 4.9 - 8.2	51	50	41	37	32	22
		800	0.120	0.034	13 - 20 - 30	33	378	29.9	8.5	4.0 - 5.9 - 9.0	55	54	46	41	37	28
	1080	0.219	0.062	18 - 24 - 35	40	510	54.5	15.4	5.3 - 7.4 - 10.5	62	60	53	49	46	37	
	5'	250	0.011	0.002	3 - 5 - 11	-	118	2.6	0.5	1.0 - 1.7 - 3.3	30	30	19	12	-	-
		530	0.047	0.010	8 - 12 - 23	23	250	11.8	2.4	2.3 - 3.5 - 7.0	46	45	36	31	25	14
670		0.076	0.015	10 - 15 - 27	29	316	18.8	3.8	3.0 - 4.4 - 8.3	50	50	41	36	32	22	
810		0.111	0.022	12 - 18 - 30	33	382	27.5	5.6	3.6 - 5.4 - 9.1	54	54	46	41	37	27	
1090	0.200	0.040	16 - 24 - 35	40	514	49.8	10.1	4.8 - 7.2 - 10.5	60	60	52	48	45	37		

NOTE: See notes on page E1-30.

LINEAR SLOT DIFFUSERS

DESIGN FLO

**DFL Performance Data: For Lay-In T-Bar (DFB) & Narrow-T (DFNT), Vertical Throw**

**IP/METRIC DATA: DFB/DFNT, 2-SLOT (VT BLADES)**

	Linear Length	IP Data				NC	Metric Data				Octave Band, dB					
		Air Flow	Pressures		Perpendicular Throw		Air Flow	Pressures		Perpendicular Throw						
			Pt	Ps				Pt	Ps							
		CFM	"WG	"WG	ft		L/s	Pa	Pa	m	2	3	4	5	6	7
3" Slot Width 10" Inlet	2'	210	0.022	0.007	5 - 8 - 15	11	99	5.4	1.8	1.5 - 2.2 - 4.4	37	35	24	18	-	-
		410	0.088	0.027	10 - 15 - 21	27	193	22.0	6.8	2.9 - 4.3 - 6.5	50	49	39	34	29	19
		510	0.137	0.042	13 - 17 - 24	32	241	34.0	10.5	3.6 - 5.1 - 7.2	55	53	44	39	35	26
		610	0.196	0.060	15 - 18 - 26	37	288	48.7	15.0	4.3 - 5.6 - 7.9	59	57	48	44	41	32
		810	0.345	0.106	17 - 21 - 30	44	382	85.9	26.4	5.2 - 6.4 - 9.1	64	63	55	51	49	41
	4'	230	0.021	0.002	4 - 6 - 12	11	109	5.3	0.5	1.1 - 1.7 - 3.4	35	35	24	17	-	-
		450	0.082	0.008	8 - 12 - 22	28	212	20.4	2.0	2.2 - 3.3 - 6.7	49	49	39	33	29	20
		560	0.127	0.013	10 - 15 - 25	33	264	31.6	3.2	2.8 - 4.2 - 7.6	53	53	44	38	35	27
		670	0.181	0.018	12 - 18 - 27	37	316	45.2	4.5	3.3 - 5.0 - 8.3	57	57	48	43	40	32
		890	0.320	0.032	16 - 22 - 31	44	420	79.7	8.0	4.4 - 6.6 - 9.5	63	63	55	50	48	41
	5'	240	0.022	0.001	4 - 6 - 11	12	113	5.6	0.4	0.9 - 1.6 - 3.2	35	35	24	17	-	-
		470	0.086	0.006	7 - 11 - 22	28	222	21.4	1.4	2.1 - 3.1 - 6.2	49	49	39	33	29	20
585		0.133	0.009	9 - 14 - 25	33	276	33.2	2.2	2.6 - 3.9 - 7.7	53	54	44	39	35	27	
700		0.191	0.013	11 - 17 - 28	38	330	47.5	3.2	3.1 - 4.6 - 8.4	57	58	48	43	40	33	
930		0.337	0.022	15 - 22 - 32	45	439	83.9	5.6	4.1 - 6.2 - 9.7	63	63	55	50	48	42	
3" Slot Width 12" Inlet	2'	230	0.015	0.009	6 - 9 - 16	-	109	3.8	2.1	1.6 - 2.4 - 4.8	33	30	18	12	-	-
		490	0.071	0.039	12 - 16 - 23	23	231	17.7	9.7	3.4 - 5.0 - 7.1	48	45	36	31	25	13
		620	0.114	0.062	15 - 18 - 26	29	293	28.4	15.5	4.3 - 5.6 - 8.0	53	50	41	36	31	21
		750	0.167	0.091	17 - 20 - 29	33	354	41.5	22.7	5.0 - 6.2 - 8.7	57	54	46	41	37	27
		1010	0.302	0.165	19 - 24 - 33	40	477	75.3	41.1	5.9 - 7.2 - 10.1	63	60	52	48	45	36
	4'	250	0.011	0.003	4 - 7 - 13	-	118	2.7	0.6	1.2 - 1.9 - 3.7	31	30	18	11	-	-
		530	0.049	0.011	9 - 14 - 24	23	250	12.2	2.8	2.6 - 3.9 - 7.4	47	45	35	29	24	13
		670	0.079	0.018	12 - 18 - 27	29	316	19.6	4.5	3.3 - 5.0 - 8.3	51	50	41	35	30	21
		810	0.115	0.027	14 - 21 - 30	33	382	28.6	6.6	4.0 - 6.0 - 9.1	55	54	45	40	36	27
		1090	0.208	0.048	19 - 25 - 35	40	514	51.7	12.0	5.4 - 7.5 - 10.5	61	60	52	47	44	36
	5'	260	0.011	0.002	4 - 6 - 12	-	123	2.7	0.4	1.1 - 1.7 - 3.4	31	30	18	11	-	-
		550	0.049	0.008	9 - 13 - 25	23	260	12.1	2.0	2.4 - 3.6 - 7.3	46	46	35	29	24	14
695		0.077	0.013	11 - 17 - 28	29	328	19.3	3.1	3.1 - 4.6 - 8.4	51	50	41	35	30	21	
840		0.113	0.018	13 - 20 - 30	34	396	28.2	4.6	3.7 - 5.6 - 9.3	55	54	45	40	36	27	
1130		0.205	0.033	18 - 25 - 35	41	533	51.0	8.2	5.0 - 7.5 - 10.7	61	61	52	47	44	36	

NOTES: Throw values are given for terminal velocities of 150, 100, and 50 FPM (0.75, 0.50, and 0.25 m/s). NC values are based on octave band 2 - 7 sound power levels minus a room absorption of 10dB, re 10<sup>-12</sup> Watts. Dash in space denotes a NC or dB value of less than 10. Data was obtained from tests conducted in accordance with ANSI/ASHRAE Standard 70, ISO Standard 5219, and ISO Standard 3741. For return applications, add 3 NC to supply data; static pressure is equal to supply total pressure. See selection software for performance data not shown, including octave band data.

LINEAR SLOT DIFFUSERS

DESIGN FLO

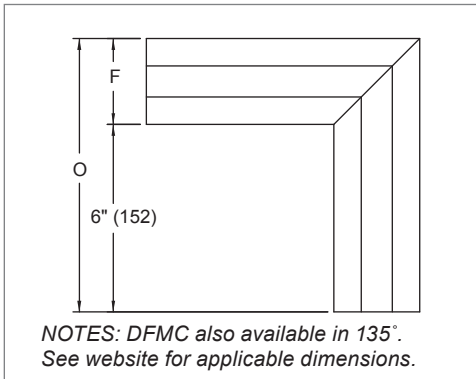
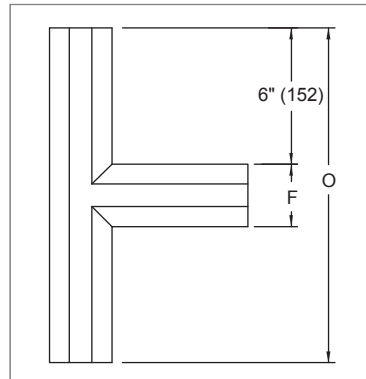
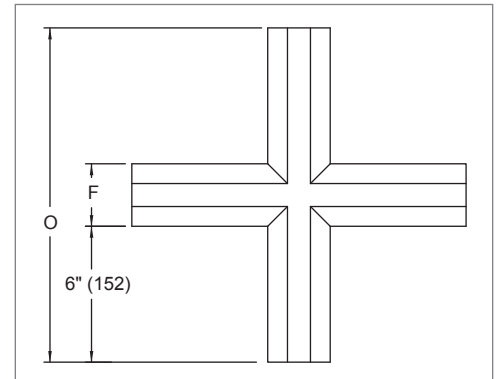
**DFL Mitered Corner (DFMC) & Transitions (DFT/DFC)**
**MITERED CORNER (DFMC)**

**TRANSITION (DFT)**

**TRANSITION (DFC)**

**MITERED CORNER (DFMC), AVAILABLE SIZES**

Number of Slots	Slot Width	Frame Type											
		AA		AC, CA		AD, DA		BB		CC		FF	
		F	O	F	O	F	O	F	O	F	O	F	O
1	1" (25)	2 3/4" (70)	8 3/4" (222)	2 15/16" (75)	8 15/16" (227)	2 3/4" (70)	8 3/4" (222)	4 1/4" (108)	10 1/4" (260)	3 1/8" (79)	9 1/8" (232)	3 3/4" (95)	9 3/4" (248)
	1 1/2" (38)	3 3/4" (95)	9 3/4" (248)	3 15/16" (100)	9 15/16" (252)	3 3/4" (95)	9 3/4" (248)	5 1/4" (133)	11 1/4" (286)	4 1/8" (105)	10 1/8" (257)	4 3/4" (121)	10 3/4" (273)
	2" (51)	4 3/4" (121)	10 3/4" (273)	4 15/16" (125)	10 15/16" (278)	4 3/4" (121)	10 3/4" (273)	6 1/4" (159)	12 1/4" (311)	5 1/8" (130)	11 1/8" (283)	5 3/4" (146)	11 3/4" (298)
	2 1/2" (64)	5 3/4" (146)	11 3/4" (298)	5 15/16" (151)	11 15/16" (303)	-	-	-	-	6 1/8" (156)	12 1/8" (308)	6 3/4" (171)	12 3/4" (324)
	3" (76)	6 3/4" (171)	12 3/4" (324)	6 15/16" (176)	12 15/16" (329)	-	-	-	-	7 1/8" (181)	13 1/8" (333)	7 3/4" (197)	13 3/4" (349)
2	1" (25)	5 3/16" (132)	11 3/16" (284)	5 3/8" (137)	11 3/8" (289)	-	-	-	-	5 9/16" (141)	11 9/16" (294)	6 3/16" (157)	12 3/16" (310)
	1 1/2" (38)	7 3/16" (183)	13 3/16" (335)	7 3/8" (187)	13 3/8" (340)	-	-	-	-	7 9/16" (192)	13 9/16" (344)	8 3/16" (208)	14 3/16" (360)
	2" (51)	9 3/16" (233)	15 3/16" (386)	9 3/8" (238)	15 3/8" (391)	-	-	-	-	9 9/16" (243)	15 9/16" (395)	10 3/16" (259)	16 3/16" (411)
	2 1/2" (64)	11 3/16" (284)	17 3/16" (437)	11 3/8" (289)	17 3/8" (441)	-	-	-	-	11 9/16" (294)	17 9/16" (446)	12 3/16" (310)	18 3/16" (462)
	3" (76)	13 3/16" (335)	19 3/16" (487)	13 3/8" (340)	19 3/8" (492)	-	-	-	-	13 9/16" (344)	19 9/16" (497)	14 3/16" (360)	20 3/16" (513)

**TRANSITIONS (DFT/DFC), AVAILABLE SIZES**

Number of Slots	Slot Width	Frame Type							
		AA		BB		CC		FF	
		F	O	F	O	F	O	F	O
1	1" (25)	2 3/4" (70)	14 3/4" (375)	4 1/4" (108)	16 1/4" (413)	3 1/8" (79)	15 1/8" (384)	3 3/4" (95)	15 3/4" (400)
	1 1/2" (38)	3 3/4" (95)	15 3/4" (400)	5 1/4" (133)	17 1/4" (438)	4 1/8" (105)	16 1/8" (410)	4 3/4" (121)	16 3/4" (425)
	2" (51)	4 3/4" (121)	16 3/4" (425)	6 1/4" (159)	18 1/4" (464)	5 1/8" (130)	17 1/8" (435)	5 3/4" (146)	17 3/4" (451)
	2 1/2" (64)	5 3/4" (146)	17 3/4" (451)	-	-	6 1/8" (156)	18 1/8" (460)	6 3/4" (171)	18 3/4" (476)
	3" (76)	6 3/4" (171)	18 3/4" (476)	-	-	7 1/8" (181)	19 1/8" (486)	7 3/4" (197)	19 3/4" (502)

NOTES: Dimensions in parentheses are mm. Dash indicates not available. Transitions and mitered corners are inactive. Blank-offs are installed at the factory.

**DFL Suggested Specification & Configuration: Frame AA & CC****DESIGNFLO® (DFL) WITH FRAME AA & CC**

Linear slot diffusers shall be Krueger DesignFlo® series for supply or return with slot widths of 1", 1 1/2", 2", 2 1/2", and 3" available. Linear slot diffusers shall be available in single piece construction up to 12'. Slot diffuser lengths greater than 12' shall be furnished in multiple sections and will be joined together with end alignment strips to form a continuous slot appearance. Alignment strips to be provided by the manufacturer.

The linear slot diffuser shall have the ability to mount flush perpendicular to a wall (Frame A) or provide a 3/16" flange (Frame C) on both sides of the linear.

The linear slot diffuser shall have the ability to support the ceiling with which it comes in contact. Brackets which are integral to the diffuser must allow mounting in hard ceilings and suspended ceilings. Linear diffusers supported by the plenum are not acceptable.

The plenums shall be manufactured by the same manufacturer as the linear slot diffuser.

Pattern controllers shall be of two piece extruded aluminum construction. Pattern controllers shall be assembled on 24" centers and supported by permanently lubricated fire retardant polymer spacers. The pair of pattern controllers shall allow for the airstream to be directed along the ceiling in either direction. The pattern controllers must also allow the airflow to be adjusted. Airflow rate can be varied without changing the air pattern. The pattern controllers in the diffuser that control the air pattern and flow rate shall perform these functions satisfactorily without the use of an additional damper.

The design of the spacers shall allow for removal and installation of pattern controllers without disassembly of the slot diffuser. The spacers shall be self lubricating, allowing for easy adjustment of pattern controllers. The region of the spacer which is in direct contact with plenum supply air shall have an airfoil design.

The face of the linear diffuser shall be #44 British White. All other surfaces including pattern controllers shall be black.

**PERFORMANCE**

The manufacturer shall provide published (printed or electronic) performance data for the diffuser. Performance data shall include 2 - 7 octave band sound power levels. The diffuser shall be tested in accordance to the data standards at the time of product introduction or ANSI/ASHRAE Standard 70.

**1. SERIES: (XXX)**

DFL - DesignFlo®, Architectural Linear Ceiling Diffuser (Frame Style AA & CC)

**2. SLOT LENGTH: (XXX) \***

12" through 999" in 1/8" Increments

**3. SLOT WIDTH: (XX)**

10 - 1"  
 15 - 1 1/2"  
 20 - 2"  
 25 - 2 1/2"  
 30 - 3"

**4. NUMBER OF SLOTS: (XX)**

01 - 1-Slot  
 02 - 2NV (2-Slot, Narrow Reveal)  
 03 - 2WV (2-Slot, Wide Reveal)  
 04 - 2AB (2-Slot, No Reveal)

**5. END BORDER: (XX)**

01 - Mitered, Both Ends †  
 02 - Mitered, One End †  
 03 - Butt Cut  
 04 - End Plate, Both Ends  
 05 - End Plate, One End  
 06 - End Cap, Both Ends  
 07 - End Cap, One End Only

**6. FRAME: (XX)**

AA - No Flange, Both Sides  
 CC - 3/16" Flange, Both Sides

**7. DEFLECTION: (XX)**

00 - No Blades  
 HT - Horizontal Throw Deflectors  
 VT - Vertical Throw Deflectors

**8. MOUNTING BRACKET: LEFT & RIGHT (XX) (XX) \*\*\***

[H1 - H3] - Hard Ceiling Bracket 1, 2, or 3  
 [W1 - W3] - Wall Bracket 1, 2, or 3  
 SS - Spline Support  
 US - Upper Support Hanger

**9. FINISH: (XX) \*\***

35 - Black  
 44 - British White

\* Maximum single unit length is 144".

\*\* Finish applies to rail only. Spacers and pattern controllers are black.

\*\*\* See page E1-7 for mounting bracket and frame type availability.

† Available on one slot units only.

**SAMPLE CONFIGURATION: DFL - 144 - 15 - 01 - 03 - AA - HT - H2 - H2 - 44**

**DFL Suggested Specification & Configuration: Frame AC & CA**

- 1. SERIES: (XXX)**  
 DFL - DesignFlo®, Architectural Linear Ceiling Diffuser (Frame Style AC & CA)
- 2. SLOT LENGTH: (XXX) \***  
 12" through 999" in 1/8" Increments
- 3. SLOT WIDTH: (XX)**  
 10 - 1"  
 15 - 1 1/2"  
 20 - 2"  
 25 - 2 1/2"  
 30 - 3"
- 4. NUMBER OF SLOTS: (XX)**  
 01 - 1-Slot  
 02 - 2NV (2-Slot, Narrow Reveal)  
 03 - 2WV (2-Slot, Wide Reveal)  
 04 - 2AB (2-Slot, No Reveal)
- 5. END BORDER: (XX)**  
 03 - Butt Cut  
 04 - End Plate, Both Ends  
 05 - End Plate, One End  
 06 - End Cap, Both Ends  
 07 - End Cap, One End Only
- 6. FRAME: (XX)**  
 AC - No Flange Left, 3/16" Flange Right  
 CA - 3/16" Flange Left, No Flange Right
- 7. DEFLECTION: (XX)**  
 00 - No Blades  
 HT - Horizontal Throw Deflectors  
 VT - Vertical Throw Deflectors
- 8. MOUNTING BRACKET: LEFT & RIGHT (XX) (XX) \*\*\***  
 H1 - Hard Ceiling Bracket 1  
 H2 - Hard Ceiling Bracket 2  
 W1 - Wall Bracket 1  
 W2 - Wall Bracket 2  
 W3 - Wall Bracket 3  
 SS - Spline Support  
 US - Upper Support Hanger
- 9. FINISH: (XX) \*\***  
 35 - Black  
 44 - British White

\* Maximum single unit length is 144".

\*\* Finish applies to rail only. Spacers and pattern controllers are black.

\*\*\* See page E1-7 for mounting bracket and frame type availability.

**DESIGNFLO® (DFL) WITH FRAME AC & CA**

Linear slot diffusers shall be Krueger DesignFlo® series for supply or return with slot widths of 1", 1 1/2", 2", 2 1/2", and 3" available. Linear slot diffusers shall be available in single piece construction up to 12'. Slot diffuser lengths greater than 12' shall be furnished in multiple sections and will be joined together with end alignment strips to form a continuous slot appearance. Alignment strips to be provided by the manufacturer.

The linear slot diffuser shall have the ability to mount flush perpendicular to a wall (Frame A) on one side and provide a 3/16" flange (Frame C) on the other side.

The linear slot diffuser shall have the ability to support the ceiling with which it comes in contact. Brackets which are integral to the diffuser must allow mounting in hard ceilings and suspended ceilings. Linear diffusers supported by the plenum are not acceptable.

The plenums shall be manufactured by the same manufacturer as the linear slot diffuser.

Pattern controllers shall be of two piece extruded aluminum construction. Pattern controllers shall be assembled on 24" centers and supported by permanently lubricated fire retardant polymer spacers. The pair of pattern controllers shall allow for the airstream to be directed along the ceiling in either direction. The pattern controllers must also allow the airflow to be adjusted. Airflow rate can be varied without changing the air pattern. The pattern controllers in the diffuser that control the air pattern and flow rate shall perform these functions satisfactorily without the use of an additional damper.

The design of the spacers shall allow for removal and installation of pattern controllers without disassembly of the slot diffuser. The spacers shall be self lubricating, allowing for easy adjustment of pattern controllers. The region of the spacer which is in direct contact with plenum supply air shall have an airfoil design.

The face of the linear diffuser shall be #44 British White. All other surfaces including pattern controllers shall be black.

**PERFORMANCE**

The manufacturer shall provide published (printed or electronic) performance data for the diffuser. Performance data shall include 2 - 7 octave band sound power levels. The diffuser shall be tested in accordance to the data standards at the time of product introduction or ANSI/ASHRAE Standard 70.



**DFL Suggested Specification & Configuration: Frame AD & DA**

**DESIGNFLO® (DFL) WITH FRAME AD & DA**

Linear slot diffusers shall be Krueger DesignFlo® series for supply or return with slot widths of 1", 1 1/2", and 2" available. Linear slot diffusers shall be available in single piece construction up to 12'. Slot diffuser lengths greater than 12' shall be furnished in multiple sections and will be joined together with end alignment strips to form a continuous slot appearance. Alignment strips to be provided by the manufacturer.

The linear slot diffuser shall have the ability to mount flush perpendicular to a wall (Frame A) on one side and provide a 5/8" step-down on the other side (Frame D) allowing for installation between ceiling and wall.

The linear slot diffuser shall have the ability to support the ceiling with which it comes in contact. Brackets which are integral to the diffuser must allow mounting in hard ceilings and suspended ceilings. Linear diffusers supported by the plenum are not acceptable.

The plenums shall be manufactured by the same manufacturer as the linear slot diffuser.

Pattern controllers shall be of two piece extruded aluminum construction. Pattern controllers shall be assembled on 24" centers and supported by permanently lubricated fire retardant polymer spacers. The pair of pattern controllers shall allow for the airstream to be directed along the ceiling in either direction. The pattern controllers must also allow the airflow to be adjusted. Airflow rate can be varied without changing the air pattern. The pattern controllers in the diffuser that control the air pattern and flow rate shall perform these functions satisfactorily without the use of an additional damper.

The design of the spacers shall allow for removal and installation of pattern controllers without disassembly of the slot diffuser. The spacers shall be self lubricating, allowing for easy adjustment of pattern controllers. The region of the spacer which is in direct contact with plenum supply air shall have an airfoil design.

The face of the linear diffuser shall be #44 British White. All other surfaces including pattern controllers shall be black.

**PERFORMANCE**

The manufacturer shall provide published (printed or electronic) performance data for the diffuser. Performance data shall include 2 - 7 octave band sound power levels. The diffuser shall be tested in accordance to the data standards at the time of product introduction or ANSI/ASHRAE Standard 70.

- 1. SERIES: (XXX)**  
DFL - DesignFlo®, Architectural Linear Ceiling Diffuser (Frame Style AD & DA)
- 2. SLOT LENGTH: (XXX) \***  
12" through 999" in 1/8" Increments
- 3. SLOT WIDTH: (XX)**  
10 - 1"  
15 - 1 1/2"  
20 - 2"
- 4. NUMBER OF SLOTS: (XX)**  
01 - 1-Slot
- 5. END BORDER: (XX)**  
03 - Butt Cut  
04 - End Plate, Both Ends  
05 - End Plate, One End
- 6. FRAME: (XX)**  
AD - No Flange Left, 5/8" Step-down Flange Right  
DA - 5/8" Step-down Flange Left, No Flange Right
- 7. DEFLECTION: (XX)**  
00 - No Blades  
HT - Horizontal Throw Deflectors
- 8. MOUNTING BRACKET: LEFT & RIGHT (XX) (XX) \*\*\***  
H3 - Hard Ceiling Bracket 3  
H4 - Hard Ceiling Bracket 4  
W2 - Wall Bracket 2  
W3 - Wall Bracket 3  
SS - Spline Support  
US - Upper Hanger Bracket (1-Slot)
- 9. FINISH: (XX) \*\***  
35 - Black  
44 - British White

\* Maximum single unit length is 144".

\*\* Finish applies to rail only. Spacers and pattern controllers are black.

\*\*\* See page E1-7 for mounting bracket and frame type availability.

LINEAR SLOT DIFFUSERS

DESIGN FLO

**SAMPLE CONFIGURATION: DFL - 72 - 10 - 01 - 04 - AD - HT - H3 - H4 - 44**

**DFL Suggested Specification & Configuration: Frame BB**
**1. SERIES: (XXX)**

DFL - DesignFlo®, Architectural Linear Ceiling Diffuser (Frame Style BB)

**2. SLOT LENGTH: (XXX) \***

12" through 999" in 1/8" Increments

**3. SLOT WIDTH: (XX)**

 10 - 1"  
 15 - 1 1/2"  
 20 - 2"  
 25 - 2 1/2"  
 30 - 3"

**4. NUMBER OF SLOTS: (XX)**

 01 - 1-Slot  
 02 - 2NV (2-Slot, Narrow Reveal)

**5. END BORDER: (XX)**

 03 - Butt Cut  
 04 - End Plate, Both Ends  
 05 - End Plate, One End

**6. FRAME: (XX)**

BB - Flanges that Accept a Finishing Compound on Both Sides

**7. DEFLECTION: (XX)**

 00 - No Blades  
 HT - Horizontal Throw Deflectors  
 VT - Vertical Throw Deflectors

**8. MOUNTING BRACKET: LEFT & RIGHT (XX) (XX)**

 H1 - Hard Ceiling Bracket 1  
 H3 - Hard Ceiling Bracket 3

**9. FINISH: (XX)**

35 - Black

\* Maximum single unit length is 144".

**DESIGNFLO® (DFL) WITH FRAME BB**

Linear slot diffusers shall be Krueger DesignFlo® series for supply or return with slot widths of 1", 1 1/2", 2", 2 1/2", and 3" available. Linear slot diffusers shall be available in single piece construction up to 12'. Slot diffuser lengths greater than 12' shall be furnished in multiple sections and will be joined together with end alignment strips to form a continuous slot appearance. Alignment strips to be provided by the manufacturer.

The linear slot diffuser shall have the ability for a finishing compound to cover the flange (Frame B) on both sides resulting in a "No-Frame" appearance.

The linear slot diffuser shall have the ability to support the ceiling. Brackets which are integral to the diffuser must allow mounting in hard ceilings and suspended ceilings. Linear diffusers supported by the plenum are not acceptable.

The plenums shall be manufactured by the same manufacturer as the linear slot diffuser.

Pattern controllers shall be of two piece extruded aluminum construction. Pattern controllers shall be assembled on 24" centers and supported by permanently lubricated fire retardant polymer spacers. The pair of pattern controllers shall allow for the airstream to be directed along the ceiling in either direction. The pattern controllers must also allow the airflow to be adjusted. Airflow rate can be varied without changing the air pattern. The pattern controllers in the diffuser that control the air pattern and flow rate shall perform these functions satisfactorily without the use of an additional damper.

The design of the spacers shall allow for removal and installation of pattern controllers without disassembly of the slot diffuser. The spacers shall be self lubricating, allowing for easy adjustment of pattern controllers. The region of the spacer which is in direct contact with plenum supply air shall have an airfoil design.

The face of the linear diffuser shall be #35 Black. All other surfaces including pattern controllers shall be black.

**PERFORMANCE**

The manufacturer shall provide published (printed or electronic) performance data for the diffuser. Performance data shall include 2 - 7 octave band sound power levels. The diffuser shall be tested in accordance to the data standards at the time of product introduction or ANSI/ASHRAE Standard 70.

**DFL Suggested Specification & Configuration: Frame FF****DESIGNFLO® (DFL) WITH FRAME FF**

Linear slot diffusers shall be Krueger DesignFlo® series for supply or return with slot widths of 1", 1 1/2", 2", 2 1/2", and 3" available. Linear slot diffusers shall be available in single piece construction up to 12'. Slot diffuser lengths greater than 12' shall be furnished in multiple sections and will be joined together with end alignment strips to form a continuous slot appearance. Alignment strips to be provided by the manufacturer.

The linear slot diffuser shall have a 1/2" flange border (Frame F) on both sides of the linear.

The linear slot diffuser shall have the ability to support the ceiling. Brackets which are integral to the diffuser must allow mounting in hard ceilings and suspended ceilings. Linear diffusers supported by the plenum are not acceptable.

The plenums shall be manufactured by the same manufacturer as the linear slot diffuser.

Pattern controllers shall be of two piece extruded aluminum construction. Pattern controllers shall be assembled on 24" centers and supported by permanently lubricated fire retardant polymer spacers. The pair of pattern controllers shall allow for the airstream to be directed along the ceiling in either direction. The pattern controllers must also allow the airflow to be adjusted. Airflow rate can be varied without changing the air pattern. The pattern controllers in the diffuser that control the air pattern and flow rate shall perform these functions satisfactorily without the use of an additional damper.

The design of the spacers shall allow for removal and installation of pattern controllers without disassembly of the slot diffuser. The spacers shall be self lubricating, allowing for easy adjustment of pattern controllers. The region of the spacer which is in direct contact with plenum supply air shall have an airfoil design.

The face of the linear diffuser shall be #44 British White. All other surfaces including pattern controllers shall be black.

**PERFORMANCE**

The manufacturer shall provide published (printed or electronic) performance data for the diffuser. Performance data shall include 2 - 7 octave band sound power levels. The diffuser shall be tested in accordance to the data standards at the time of product introduction or ANSI/ASHRAE Standard 70.

**1. SERIES: (XXX)**

DFL - DesignFlo®, Architectural Linear Ceiling Diffuser (Frame Style FF)

**2. SLOT LENGTH: (XXX) \***

12" through 999" in 1/8" Increments

**3. SLOT WIDTH: (XX)**

10 - 1"  
 15 - 1 1/2"  
 20 - 2"  
 25 - 2 1/2"  
 30 - 3"

**4. NUMBER OF SLOTS: (XX)**

01 - 1-Slot  
 02 - 2NV (2-Slot, Narrow Reveal)  
 03 - 2WV (2-Slot, Wide Reveal)

**5. END BORDER: (XX)**

01 - Mitered, Both Ends †  
 02 - Mitered, One End †  
 03 - Butt Cut  
 04 - End Plate, Both Ends  
 05 - End Plate, One End  
 06 - End Cap, Both Ends  
 07 - End Cap, One End Only

**6. FRAME: (XX)**

FF - 1/2" Flange, Both Sides

**7. DEFLECTION: (XX)**

00 - No Blades  
 HT - Horizontal Throw Deflectors  
 VT - Vertical Throw Deflectors

**8. MOUNTING BRACKET: LEFT & RIGHT (XX) (XX) \*\*\***

H1 - Hard Ceiling Bracket 1  
 W2 - Wall Bracket 2  
 SS - Spline Support  
 US - Upper Support Hanger  
 CF - Concealed Fastener

**9. FINISH: (XX) \*\***

35 - Black  
 44 - British White

\* Maximum single unit length is 144".

\*\* Finish applies to rail only. Spacers and pattern controllers are black.

\*\*\* See page E1-7 for mounting bracket and frame type availability.

† Available on one slot units only.

**SAMPLE CONFIGURATION: DFL - 59 - 30 - 03 - 06 - FF - VT - W2 - W2 - 44**

## Plenum (DFP) Suggested Specification & Configuration

**1. SERIES: (XXX)**

DFP - DesignFlo® Plenum

**2. SLOT LENGTH: (XX)**

 24"  
 36"  
 48"  
 60"

**3. SLOT WIDTH: (XX)**

 10 - 1"  
 15 - 1 1/2"  
 20 - 2"  
 25 - 2 1/2"  
 30 - 3"

**4. NUMBER OF SLOTS: (XX)**

 01 - 1-Slot  
 02 - 2NV (2-Slot, Narrow Reveal)  
 03 - 2WV (2-Slot, Wide Reveal)  
 04 - 2AB (2-Slot, No Reveal)

**5. PLENUM INLET: (XX)**

 06 - 6" Oval  
 08 - 8" Oval  
 10 - 10" Oval  
 12 - 12" Oval

**6. DAMPER: (XX)**

 00 - No Damper  
 01 - Quadrant Damper

**7. ACCESSORIES: PLENUM TYPE (X)**

 S - Standard  
 F - Concealed Fastening

**8. INSULATION: (XX)**

 00 - No Insulation  
 01 - Insulated

**9. FINISH: (XX)**

01 - Mill

**DESIGNFLO® PLENUM (DFP)**

Plenums for the DesignFlo® series shall be Krueger's series DFP.

The DFP shall rest on top of linear with side flanges residing in the interior of the DesignFlo® linear to prevent air leakage and interference with DesignFlo® linear mounting hardware.

The DFP shall attach to the DesignFlo® linear by means of spring clips to allow for plenum removal or attachment without means of special tools. Screw fastening plenum to linear will not be acceptable.

For the optional concealed fastening method, the DFP plenum shall have a V-shaped hemmed edge to accommodate the CF mounting bracket and to ensure a fast, secure installation.

Optional 1/4" 2 lb density insulation is available for the DFP.

The DFP shall be constructed of galvanized steel with a mill finish.

**PERFORMANCE**

The manufacturer shall provide published (printed or electronic) performance data for the diffuser. Performance data shall include 2 - 7 octave band sound power levels. The diffuser shall be tested in accordance to the data standards at the time of product introduction or ANSI/ASHRAE Standard 70.

## DFB Suggested Specification & Configuration: For Lay-In Applications

### DESIGNFLO® WITH PLENUM DFB

Linear slot diffuser shall be Krueger DesignFlo® DFB for supply or return with slot widths of 1", 1 1/2", and 2" available.

The plenum shall be supplied by the linear slot diffuser manufacturer and attached to the linear by means of spring clips to allow for plenum removal without use of special tools. Screw fastening the plenum to the linear is not acceptable.

The linear slot diffuser shall be sized to fit into a 15/16" inverted tee ceiling.

Pattern controllers shall be of two piece extruded aluminum construction. Pattern controllers shall be assembled on 24" centers and supported by permanently lubricated fire retardant polymer spacers. The pair of pattern controllers shall allow for the airstream to be directed along the ceiling in either direction. The pattern controllers must also allow the airflow to be adjusted. Airflow rate can be varied without changing the air pattern. The pattern controllers in the diffuser that control the air pattern and flow rate shall perform these functions satisfactorily without the use of an additional damper.

The design of the spacers shall allow for removal and installation of pattern controllers without disassembly of the slot diffuser. The spacers shall be self lubricating allowing for easy adjustment of pattern controllers. The region of the spacer which is in direct contact with plenum supply air shall have an airfoil design.

The face of the linear slot diffuser shall be #44 British White. All other surfaces including pattern controllers shall be black.

### PERFORMANCE

The manufacturer shall provide published (printed or electronic) performance data for the diffuser. Performance data shall include 2 - 7 octave band sound power levels. The diffuser shall be tested in accordance to the data standards at the time of product introduction or ANSI/ASHRAE Standard 70.

- 1. SERIES: (XXX)**  
DFB - DesignFlo®, Architectural Linear Ceiling Diffuser with Plenum (Frame Style AC & CC)
- 2. SLOT LENGTH: (XX)**  
24", 48", or 60"
- 3. SLOT WIDTH: (XX)**  
10 - 1"  
15 - 1 1/2"  
20 - 2"
- 4. NUMBER OF SLOTS: (XX)**  
01 - 1-Slot  
02 - 2NV (2-Slot, Narrow Reveal)  
03 - 2WV (2-Slot, Wide Reveal)  
04 - 2AB (2-Slot, No Reveal) \*
- 5. PLENUM INLET: (XX)**  
06 - 6" Oval  
08 - 8" Oval  
10 - 10" Oval  
12 - 12" Oval
- 6. FRAME: (XX)**  
AC - No Flange Left, 3/16" Flange Right  
CC - 3/16" Flange, Both Sides
- 7. DEFLECTION: (XX)**  
00 - No Blades  
HT - Horizontal Throw Deflectors  
VT - Vertical Throw Deflectors
- 8. DAMPER: (XX)**  
00 - No Damper  
01 - Quadrant Damper
- 9. MOUNTING BRACKET: LEFT & RIGHT (XX) (XX)**  
SS - Spline Support  
US - Upper Support Hanger
- 10. INSULATION: (XX)**  
00 - No Insulation  
01 - Insulated
- 11. FINISH: (XX) \*\***  
35 - Black  
44 - British White

\* T-Bar by others.

\*\* Finish applies to rail only. Spacers and pattern controllers are black.

**SAMPLE CONFIGURATION:** DFB - 24 - 15 - 01 - 08 - CC - VT - 00 - US - US - 01 - 44

**DFNT Suggested Specification & Configuration: For Bolted-T Applications**
**1. SERIES: (XXXX)**

DFNT - DesignFlo®, Architectural Linear Ceiling Diffuser for Narrow-T Grid with Plenum (Frame Style AA)

**2. SLOT LENGTH: (XX)**

24"  
48"

**3. SLOT WIDTH: (XX)**

10 - 1"  
15 - 1 1/2"  
20 - 2"

**4. NUMBER OF SLOTS: (XX)**

01 - 1-Slot  
04 - 2AB (2-Slot, No Reveal) \*

**5. PLENUM INLET: (XX)**

06 - 6" Oval  
08 - 8" Oval  
10 - 10" Oval  
12 - 12" Oval

**6. FRAME: (XX)**

AA - No Flange, Both Sides

**7. DEFLECTION: (XX)**

00 - No Blades  
HT - Horizontal Throw Deflectors  
VT - Vertical Throw Deflectors

**8. DAMPER: (XX)**

00 - No Damper  
01 - Quadrant Damper

**9. MOUNTING BRACKET: LEFT & RIGHT (XX) (XX)**

SS - Spline Support  
US - Upper Support Hanger

**10. INSULATION: (XX)**

00 - No Insulation  
01 - Insulated

**11. FINISH: (XX) \*\***

35 - Black  
44 - British White

\* T-Bar by others.

\*\* Finish applies to rail only. Spacers and pattern controllers are black.

**DESIGNFLO® WITH PLENUM DFNT**

Linear slot diffusers shall be Krueger DesignFlo™ DFNT series for supply or return with slot widths of 1", 1 1/2", and 2" available.

The plenum shall be supplied by the linear slot diffuser manufacturer and attached to the linear by means of spring clips to allow for plenum removal without use of special tools. Screw fastening the plenum to the linear is not acceptable.

The linear slot diffuser shall be sized to fit into a 9/16" bolted slot ceiling, which has a 5/16" drop built into the tee.

Pattern controllers shall be of two piece extruded aluminum construction. Pattern controllers shall be assembled on 24" centers and supported by permanently lubricated fire retardant polymer spacers. The pair of pattern controllers shall allow for the airstream to be directed along the ceiling in either direction. The pattern controllers must also allow the airflow to be adjusted. Airflow rate can be varied without changing the air pattern. The pattern controllers in the diffuser that control the air pattern and flow rate shall perform these functions satisfactorily without the use of an additional damper.

The design of the spacers shall allow for removal and installation of pattern controllers without disassembly of the slot diffuser. The spacers shall be self lubricating allowing for easy adjustment of pattern controllers. The region of the spacer which is in direct contact with plenum supply air shall have an airfoil design.

The face of the linear slot diffuser shall be #44 British White. All other surfaces including pattern controllers shall be black.

**PERFORMANCE**

The manufacturer shall provide published (printed or electronic) performance data for the diffuser. Performance data shall include 2 - 7 octave band sound power levels. The diffuser shall be tested in accordance to the data standards at the time of product introduction or ANSI/ASHRAE Standard 70.