

MagicSIGN™

www.MagicStreetSign.com

Patent No. US 8,099,261

“Low-Cost Solid State Identification Device”

Patent-pending application No. US 61,859,723

“Illuminated Building Sign with Configurable Display and Faceplate”

Patent-pending application No. US 61,864,879

Illuminated Building Sign with Configurable Display and Faceplate

Patent-pending application No. US 61,875,567

“Apparatus Real Time Control and Navigation System Using Networked Intelligent Illuminated Street Address and Directional Signs to Reduce Response Time of First Responders”

World’s first intelligent configurable color illuminated street address sign visible from 100’s of feet away consuming below 1 Watt of electricity.

OPTIONAL: Automatic adjustments of the illumination power based on ambient light, internal temperature, and remaining battery power, sustaining the sign efficiency and longevity.

OPTIONAL: Controls for indicating status, supported by networked configuration in events of emergency, reducing Response Time of First Responders attending to emergency.

Patent No. US 8,099,261: Low-cost Solid-state Identification Device

Product series: ADVS-magic.sign™ color LED backlit Signs

Specifications: PRODUCTION KIT, Model Magic.SIGN.1000

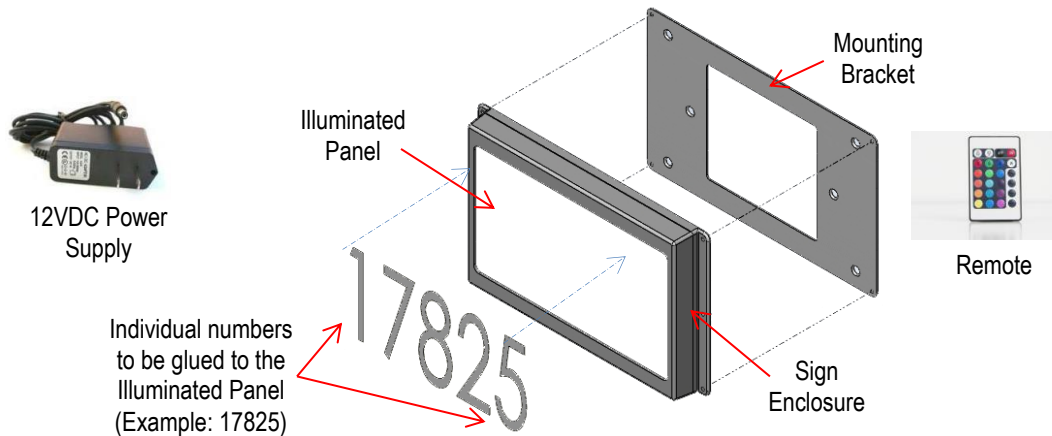

Packaging	10.5"W, 6.4"H, 1.1"D. Weight: 0.7 Lb. Light textured plastic enclosure, weather-proof, IP66, NEMA 4. 6 mounting holes. Mounting plate included. Installation required
Operating environment	-20 to 50°C, over 50,000 hours (at least 5 years continuous)
Input power rating	12VDC, 6W max. "Green technology friendly" NOTE: Depending on ambient environment, the sign can be visible while being powered by as low as 0.4W
Power source (included w/KIT)	Wall-mount power brick, 12VDC, 1A, UL Class 2, standard 2.1mm DC plug, which can be plugged-in directly into the mating connector of the Sign power cable
Power interface	Power cable ~5 feet long connecting the sign directly to the power supply, or to optional MagicPowerSplitter™ of the MagicBackupPower™
Control Functions	Manually via Infra-red remote, 24 functions, with power OFF memory. ON/OFF; Color (16 states); illumination intensity (gradual up/down 16 states); blinking with color change (4 states)
Illuminated Panel dimensions	8.75"W, 5"H
Sign content	Sign characters, such as vinyl self-adhesive outdoor numbers (sold separately) are attached to Illuminated Panel directly by gluing. Optional: Customizable SignSheets™
Made in USA	One year limited manufacturer warranty, parts and labor

Optional Features:

- MagicBackupPower™ kit, Will keep the Sign operational without electricity for min. 40 hours.
- Automatic Controls of illumination based on ambient light, internal temperature, power supply voltage
- Wireless network for real-time controls by a remote Host computer, mobile phone, via Internet



Example 1: MagicSign™ with custom SignSheet™ of **Halloween**, street address “1422”



Example 2: MagicSign™ with custom SignSheet™ of **Happy New Year**, street address “1422”



Example 3: MagicSign™ with custom SignSheet™ of **Happy 4th**, street address “1422”