

Sample Rubber Profiles from Elasto Proxy

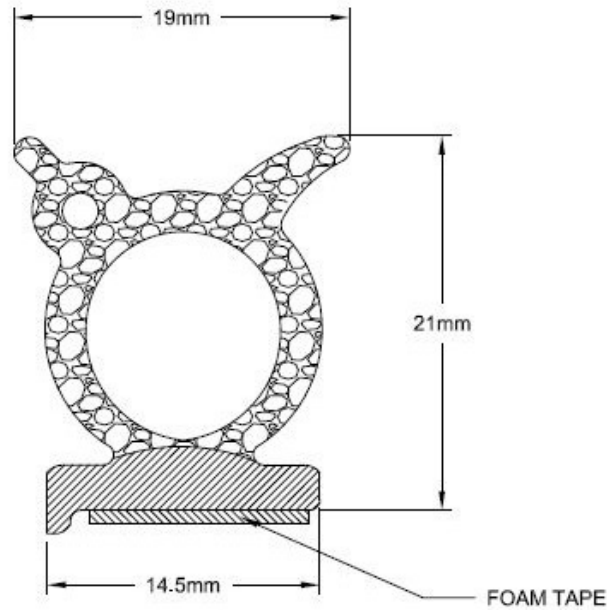

ACTUAL
SIZE



Siege social / Head Office
4035 Lavoisier
Boisbriand, Quebec
Canada J7H 1N1
Tel: 1-800-263-1450
Tel: (450) 434-2744
Fax (450) 434-5998

Drawing Approval

Drawn by
PA

Approved by
SG

Revisions

No	Description	By	Date
0	FORMAT REVISION	PA	06/19/03

Notes

Die #:

Stock #: EC04-190-EMT1

Tolerance: RMA-BEC2

Scale: Not to scale

Title: BULB SEAL

Material: EPDM SPONGE

Colour: BLACK

Duro: MEDIUM

1/1

RMA CLASS 2	
BEC 2	
MILLIMETERS	TOLERANCE
ABOVE INCLUDED	
0	±0.5
6.3	±1.0
12.5	±2.0
25.0	±3.2
40.0 & + MULT. BY	0.08

EC04-190-EMT1_REV0.dwg

Sample Rubber Profiles from Elasto Proxy

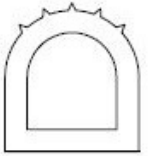

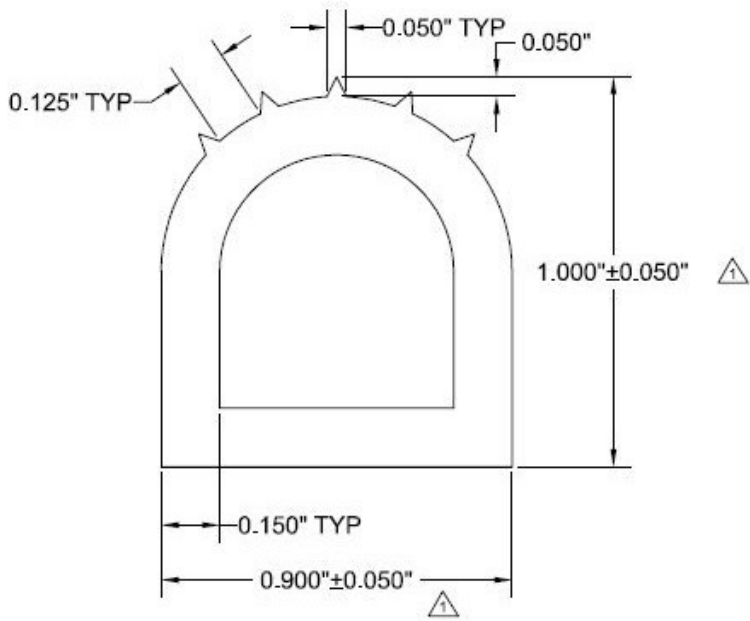

ACTUAL SIZE





Siege social / Head Office
4035 Lavoisier
Boisbriand, Quebec
Canada J7H 1N1
Tel: 1-800-263-1450
Tel: (450) 434-2744
Fax (450) 434-5998

Drawing Approval

Drawn by: 	Approved by: 
--	---

Revisions

No	Description	By	Date
0	FOR PRODUCTION	SG	03/02/00
1	ADD TOLERANCE	PG	02/01/05

Notes

50gr ±5gr/FT

Die #:

Stock #: EC12-045-EM

Tolerance: RMA-BEC2

Scale: Not to scale

Title: D-SHAPE

Material: EPDM SPONGE

Colour: BLACK

Duro: MEDIUM

1/1

RMA CLASS 2		TOLERANCE
BEC 2		
INCHES		
ABOVE	INCLUDED	
0	.25	±.020
.25	.50	±.040
.50	1.0	±.080
1.0	1.6	±.125
1.6 & +	MULT. BY	0.080

CAD#: EC12-045-EM_REV1.dwg

Sample Rubber Profiles from Elasto Proxy



ACTUAL SIZE

EC12-065-EM
EXTRUDED 2 UP

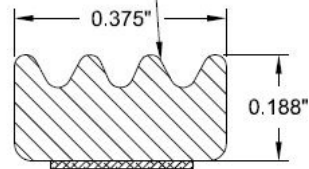

ACRYLIC TAPE



Siege social / Head Office
4035 Lavoisier
Boisbriand, Quebec
Canada J7H 1N1
Tel: 1-800-263-1450
Tel: (450) 434-2744
Fax (450) 434-5998

Drawing Approval

Drawn by:



Approved by:



Revisions

No	Description	By	Date
0	FOR PRODUCTION	PA	06/14/04

Notes

Die #:

Stock #: EC12-065-EMT

Tolerance: TBA

Scale: Not to scale

Title: TAPED EXTRUSION

Material: NEOPRENE SPONGE

Colour: BLACK

Duro: MEDIUM

1/1

Sample Rubber Profiles from Elasto Proxy

ACTUAL SIZE

22mm

16mm

14.5mm

5mm

EPDM 60 DURO



EPDM SPONGE MEDIUM DENSITY

METAL INSERT



Siege social / Head Office
4035 Lavoisier
Boisbriand, Quebec
Canada J7H 1N1
Tel: 1-800-263-1450
Tel: (450) 434-2744
Fax (450) 434-5998

Drawing Approval

Drawn by:  Approved by: 

Revisions

No	Description	By	Date
0	FORMAT REVISION	PA	06/13/03
1	DWG CHANGE TO SHOW THE REAL SHAPE	PG	25/03/08

Notes

Die #:

Stock #: EC28-215-EM

Tolerance: RMA-E2

Scale: Not to scale

Title: BULB TRIM SEAL

Material: EPDM

Colour: BLACK

Duro: MEDIUM

1 / 1

RMA-E2 Tolerances Table	
Drawing designation: Dimensions (in Millimeters)	
Above / Up to	E2 (precision)
0 - 1,5	± 0,25
1,5 - 2,5	± 0,35
2,5 - 4,0	± 0,40
4,0 - 6,3	± 0,50
6,3 - 10	± 0,70
10 - 16	± 0,90
16 - 25	± 1,00
25 - 40	± 1,30
40 - 63	± 1,60
63 - 100	± 2,00

EC28-215-EM_REV1.dwg

Sample Rubber Profiles from Elasto Proxy



ACTUAL
SIZE

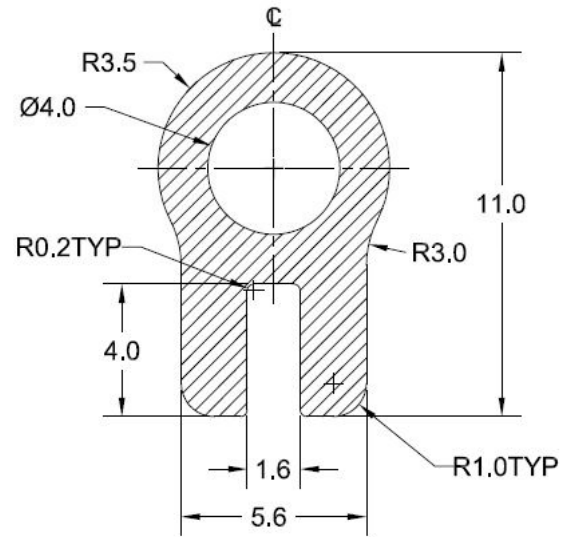

Siege social / Head Office
4035 Lavoisier
Boisbriand, Quebec
Canada J7H 1N1
Tel: 1-800-263-1450
Tel: (450) 434-2744
Fax (450) 434-5998

Drawing Approval

Drawn by:



Approved by:



Revisions

No	Description	By	Date
0	FOR PRODUCTION	SG	03/01/02
1	FORMAT REV.	SG	03/01/02

Notes

DIMENSIONS ARE IN
mm

FDA APPROVED COMPOUND CERTIFICATE
OF CONFORMANCE REQUIRED

Die #:

Stock #: ES04-006-S40

Tolerance: RMA-E2

Scale: Not to scale

Title: CROSS SECTION

Material: SILICONE

Colour: LIGHT GREY

Duro: 40 ±5

1/1

RMA-E2 Tolerances Table	
Drawing designation Dimensions (in Millimeters)	
Above / Up to	E2 (precision)
0 - 1.5	± 0.25
1.5 - 2.5	± 0.35
2.5 - 4.0	± 0.40
4.0 - 6.3	± 0.50
6.3 - 10	± 0.70
10 - 16	± 0.80
16 - 25	± 1.00
25 - 40	± 1.30
40 - 63	± 1.60
63 - 100	± 2.00

CAD#: ES04-006-S40_REV1.dwg

Sample Rubber Profiles from Elasto Proxy

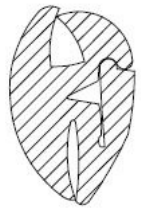

Closed position

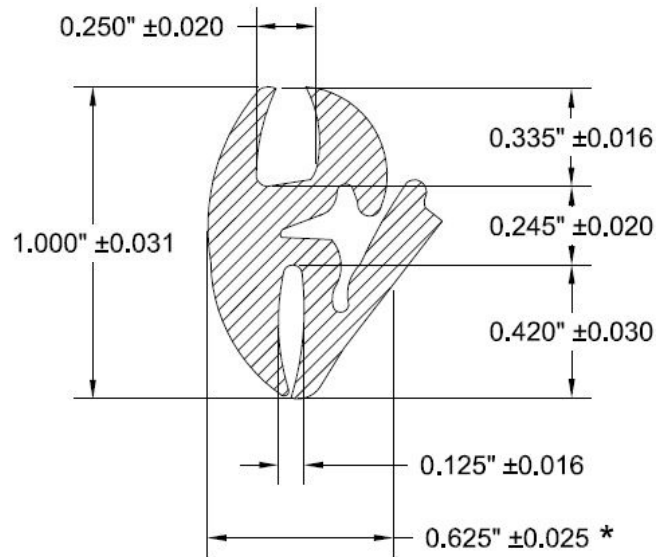

Siege social / Head Office
 4035 Lavoisier
 Boisbriand, Quebec
 Canada J7H 1N1
 Tel: 1-800-263-1450
 Tel: (450) 434-2744
 Fax (450) 434-5998

Drawing Approval

Drawn by:



Approved by:



Revisions

No	Description	By	Date
0	FOR PRODUCTION	SG	09/11/02

Notes

* THIS DIMENSION IS IN WHEN PART IS CLOSED

WAX BASED

Die #:

Stock #: ES35-321-E70

Tolerance: AS SHOWN

Scale: Not to scale

Title: WINDOW CHANNEL

Material: EPDM

Colour: BLACK

Duro: 70 ±5

1/1

ES35-321-E70_REV0.dwg

Sample Rubber Profiles from Elasto Proxy

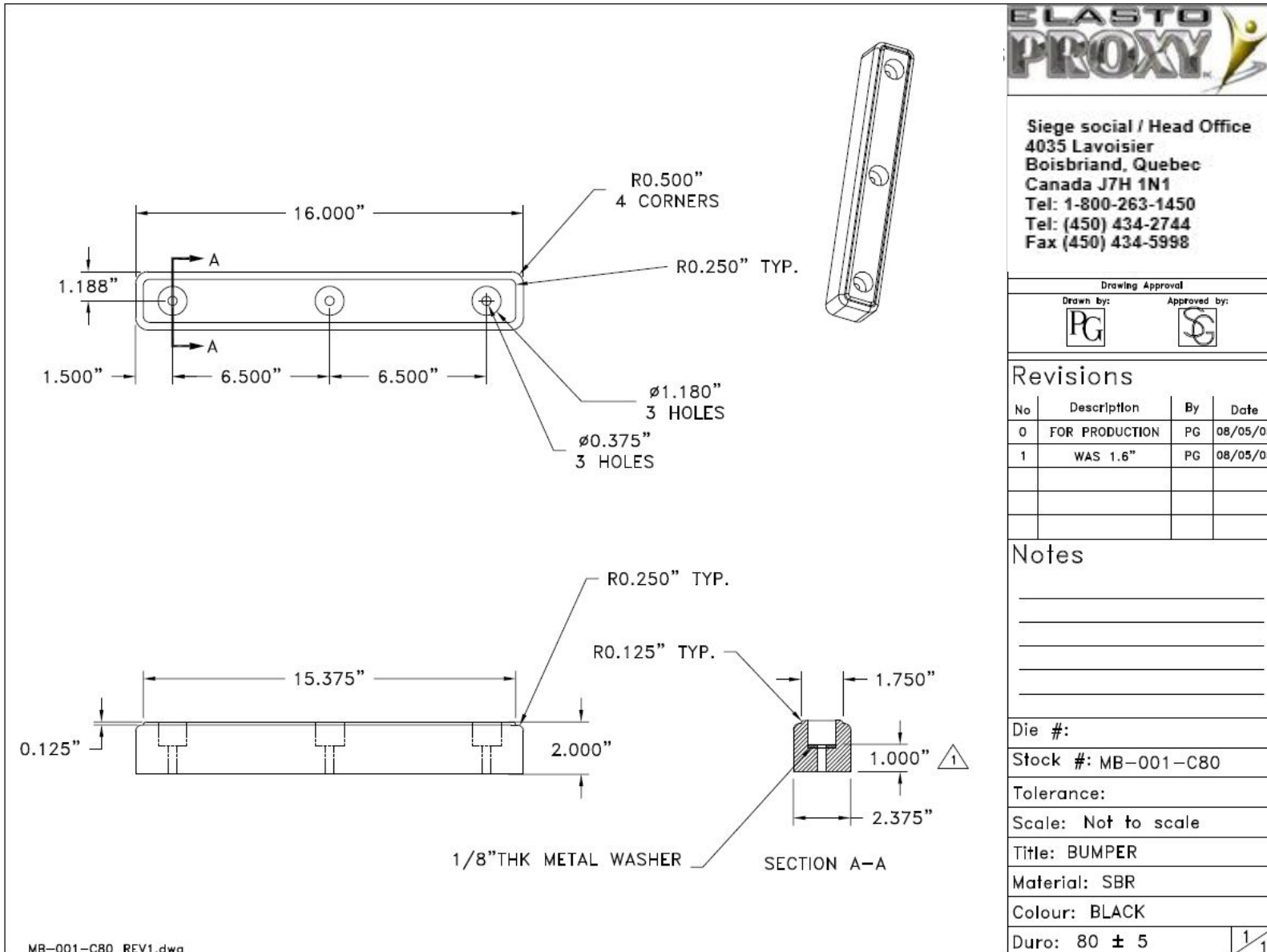

Sample Rubber Profiles from Elasto Proxy

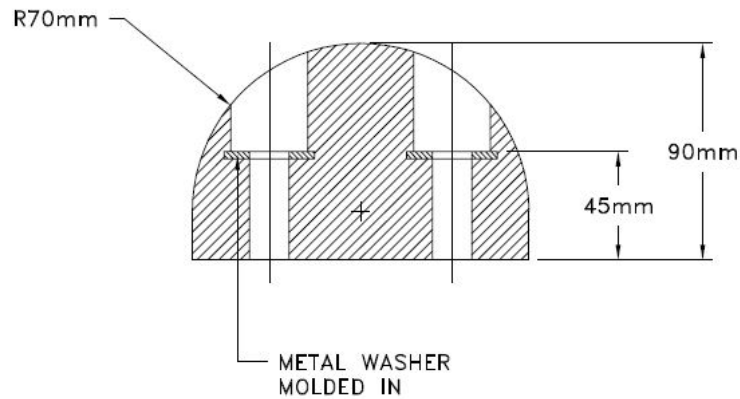
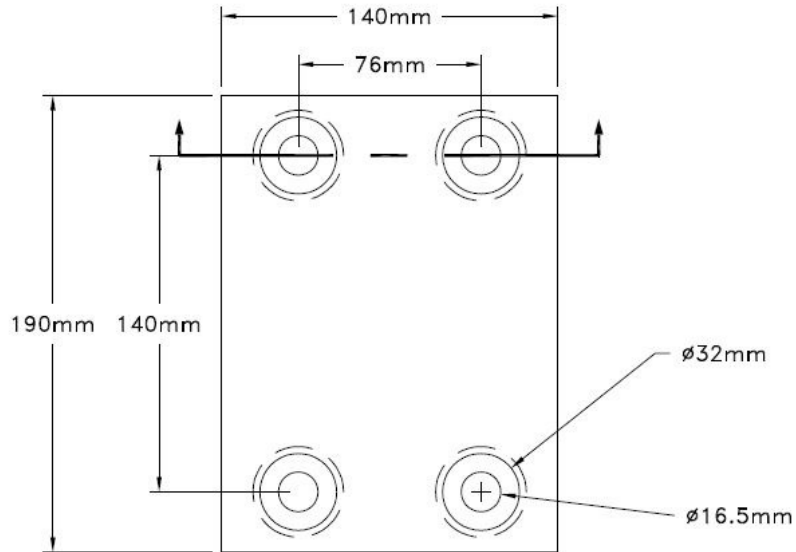

RMA-E2 Tolerances Table	
Drawing designation Dimensions (in Millimeters)	
Above / Up to	E2 (precision)
0 - 1,5	± 0,25
1,5 - 2,5	± 0,35
2,5 - 4,0	± 0,40
4,0 - 6,3	± 0,50
6,3 - 10	± 0,70
10 - 16	± 0,80
16 - 25	± 1,00
25 - 40	± 1,30
40 - 63	± 1,60
63 - 100	± 2,00

MB-060-C80_REV0.dwg



Siege social / Head Office
 4035 Lavoisier
 Boisbriand, Quebec
 Canada J7H 1N1
 Tel: 1-800-263-1450
 Tel: (450) 434-2744
 Fax (450) 434-5998

Drawing Approval

Drawn by:



Approved by:



Revisions

No	Description	By	Date
0	FOR PRODUCTION	PG	06/02/09

Notes

625-6001

Die #:

Stock #: MB-060-C80

Tolerance: RMA-E2

Scale: Not to scale

Title:

Material: SBR

Colour: BLACK

Duro: 60±5

1/1