

# **Development, Testing, and Data Collection of a Pathway Measurement Tool (PathMeT)**

**July 2014**

---

**Authors:**

**Jon Pearlman, [jl46@pitt.edu](mailto:jl46@pitt.edu)**

**Eric Sinagra, [sinagrae@gmail.com](mailto:sinagrae@gmail.com)**

**Jonathan Duvall, [jad75@pitt.edu](mailto:jad75@pitt.edu)**

**University of Pittsburgh**

**Human Engineering Research Laboratories**

**6425 Penn Ave, Suite 400**

**Pittsburgh, PA 15260**

**412-822-3710**

This report was prepared under a grant from the Interlocking Concrete Pavement Institute and the Brick Industry Association as well as grants from the United States Access Board.

## **REPORT OBJECTIVES**

The Architectural and Transportation Barriers Compliance Board (Access Board) is concerned about the amount of whole-body vibration (WBVs) exposure of wheelchair users when traversing sidewalks and pathways. Currently, the only guideline concerning pathway surfaces, states that they “shall be stable, firm, and slip resistant.” No guidelines currently exist concerning pathway roughness, safety and comfort.

The goal of this project was to develop a tool that could characterize the accessibility of pedestrian pathways based on the following parameters: flatness, running slope, cross slope, level change, and roughness. That tool, PathMeT, is capable of measuring the roughness of a pathway and resulting WBV exposure to a wheelchair user using those parameters. The report also documents the trial testing of the PathMet device to validate its performance to consistently measure the roughness of a pathway surface and the resulting WBVs caused by that roughness. Based on PathMet test data, proposed criteria have been developed to identify acceptable, marginal and unacceptable pathway roughness and WBVs.

## **EXECUTIVE SUMMARY**

The test data indicate that design, installation and maintenance are the most important factors in a compliant pathway surface. Many pathway materials can be used to create a surface that is compliant with the proposed roughness and vibration criteria. Pathway surfaces change over time depending upon many factors including but not limited to traffic, climate exposure, maintenance, etc.

Key Findings:

- 1) PathMeT is a tool that quickly, accurately, and consistently characterizes, photographs and geo-locates pathway surfaces.
- 2) Size, frequency and height of surface joints or gaps greatly affect pathway surface roughness.
- 3) Roughness is impacted primarily by the design, installation and maintenance of a pathway surface.

- 4) Next steps and additional work include additional testing and the need to formally adopt measurement guidelines within ASTM for criteria for determining pathway compliance within ADA Design Guidelines.

## **INTRODUCTION**

Design standards for pedestrian pathways have changed over time and accessibility was not mandated on a national basis until after the American Disabilities Act (ADA) was enacted in 1990. Even after this mandate, a significant amount of research and development had to be invested over an extended period of time in order to develop actual design criteria for accessible surfaces. This work continues today, as an important milestone of publishing the Public Rights of Way Guidelines is still pending. It should be noted that even after these mandates have been widely disseminated, their application to a given pathway may be different. Newly constructed pathways must comply with the most recent design standards. Alterations/reconstruction of pathways generally have to meet the most recent design standards as well, although there are exceptions depending upon the scope of the project. For existing pathways, the ADA requires at least one ‘accessible route’ to buildings and facilities. However other pathways to the building or facility constructed prior to the legislation would be exempt unless they are being altered. Therefore, when field testing, as discussed in this report, and results indicate that surfaces are non-compliant with the ‘current’ design standards, it does not necessarily indicate that the surface does not meet the mandate, since that particular surface may be exempt. Nevertheless, it is important from the perspective of accessibility to understand if a given surface meets the design criteria, regardless of whether it is required to comply with a specific mandate or not.

The ADA states that “physical or mental disabilities in no way diminish a person’s right to fully participate in all aspects of society...” [1] Title V of the ADA directs the Architectural and Transportation Barriers Compliance Board (Access Board) to create minimum guidelines “to ensure that buildings, facilities, rail passenger cars, and vehicles are accessible, in terms of architecture and design,

transportation, and communication, to individuals with disabilities.”[1] However, the Access Board has only established one guideline concerning pathway surfaces, stating that they “shall be stable, firm, and slip resistant”. [2] No guidelines currently exist that relate pathway roughness to pedestrian safety and comfort.

The need for improved pathways continues to expand and become more important for health and safety of all pedestrians, especially those who use wheelchairs. Approximately 3.6 million Americans currently use wheelchairs [3] and 26% of the population is over 55 years old, many of which have an increased risk of tripping or falling. [4] Consequently, litigation continues to increase and cost cities millions of dollars as a result of sidewalks not being compliant with the ADA. In Los Angeles, the city settled two cases about sidewalk accessibility for a total of \$85 million. Representatives from Los Angeles stated that 42% of the 10,750 miles of sidewalk are in disrepair. California has committed \$1.1 billion over the next 30 years to improving its state-controlled pedestrian pathways. Similarly, Sacramento has committed 20% of its annual transportation fund over the next 30 years to repairs of its 2,300 miles of sidewalk. [5, 6]

### **Health Risks**

One measurement that helps determine the safety and comfort of wheelchair users is their level of exposure to WBVs, which research has shown can lead to a variety of medical issues, especially with the back and neck. [7] Ailments that wheelchair users often face, such as pressure ulcers and back pain, are associated with use of rough or uneven pathways and can be detrimental to recovery. [8]

Non-wheelchair users also face potential hazards from unmaintained and unregulated pathways. Falling is the most common cause of traumatic brain injury. [9] Trips and falls are the number one cause of fatal and nonfatal injuries in older adults with 2.3 million fall-related injuries yearly, 662,000 of which resulted in hospitalization. In addition, more than 33% of people older than 65 fall each year. [9]

For the purposes of limiting WBVs in wheelchair users, the current guidelines are insufficient, making no mention of surface roughness, an important metric when the average manual and power wheelchair user travels 2.0 km [10] and 1.6 km [11] per day respectively. ISO 2631-1, *Mechanical*

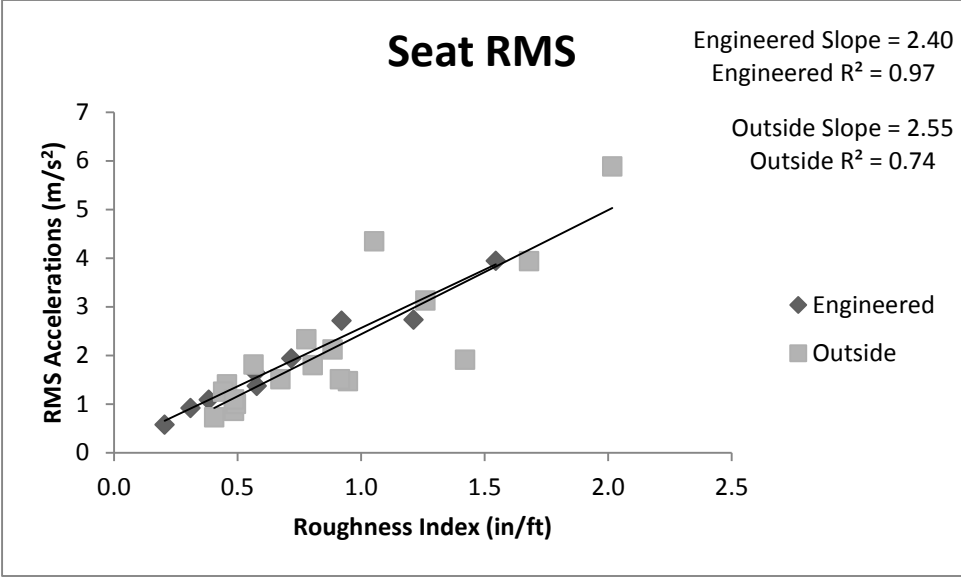
*vibration and shock -- Evaluation of human exposure to whole-body vibration*, [12] is an accepted international standard that establishes recommended limits on the exposure of humans to WBVs. Specifically, ISO 2631-1 states that a maximum exposure of an RMS value of  $1.15 \text{ m/s}^2$  over 4-8 hours is the recommended limit. In order to limit a wheelchair user's exposure to these harmful vibrations, regulations regarding the roughness of pedestrian pathways are needed.

### **Roughness Criteria**

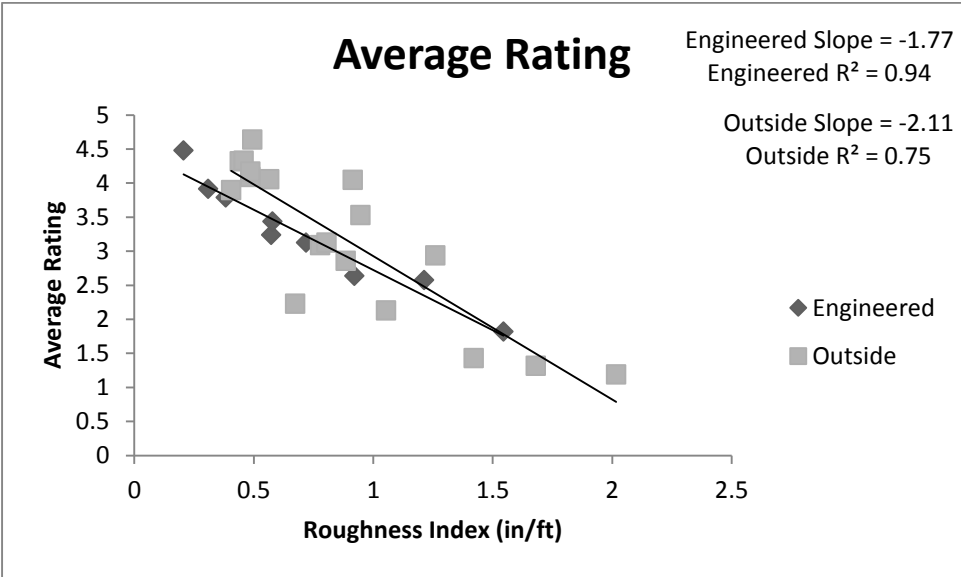
To address this need, the Access Board funded a study to investigate the correlation between surface roughness of pathways and vibrations experienced by wheelchair users as they travel over these surfaces. [13, 14] Both engineered and existing outdoor surfaces were used in the study. Nine engineered wooden surfaces were used with periodic gaps for different roughness. The gaps were 0, 0.8, 1.25, 1.55, and 2-inch widths, and were spaced every 0, 4, or 8 inches. Wheelchair users propelled their wheelchair over the surfaces three times each, while acceleration data was collected on the seat, backrest, and footrest. After crossing each surface, the wheelchair user answered questions concerning rider comfort and quality rating of the surface. An identical protocol was used over a selection of existing outdoor surfaces identified in the community.

The results from the study show that wide cracks in surfaces cause wheelchair users to be exposed to dangerous WBVs. In addition, regardless of the level of WBVs, wide cracks can cause discomfort as reported by wheelchair users. **Error! Reference source not found.** shows that as the roughness of surfaces increases, root mean square (RMS) acceleration increases. Figure 2 shows that as surface roughness increases the average rating (which is related to comfort) decreases. [13]

Measurements above the dashed line represents the cautioned zone that is suggested in the ISO 2631-1 standard. The standard specifies that RMS accelerations of  $1.6 \text{ m/s}^2$  or greater are dangerous for a wheelchair user exposed to them for a period of one hour or longer. [12] Figure 2 demonstrates that travelling over some surfaces is uncomfortable for wheelchair users, and may be harmful to their health.



**Figure 1: Indoor-Outdoor Average RMS Versus Roughness**



**Figure 2: Indoor-Outdoor Average Rating Versus Roughness**

**Next Steps**

The Public Rights of Way Guidelines (PROWG) are being finalized for publication by the U.S. Access Board, and include guidelines on pathway cross slope, running slope, and level change. Surface

roughness will be discussed in the preamble of the PROWG, but since the public review of the PROWG occurred before results of the pathway roughness research were available, it will not be explicitly included. Thus, promulgation and enforcement of the roughness criteria will likely occur after publication of PROWG and potentially be introduced in one of two ways. One possibility is when the U.S. Department of Transportation or Department of Justice adopts the PROWG, which they are widely expected to do, then the roughness criteria could be adopted simultaneously as an amendment to the PROWG. If this were to occur, then the roughness criteria could be enforceable before 2015. The second possibility is that the roughness criteria are added as an amendment to the PROWG when it is revised in 2015 or 2016.

Regardless of when roughness criteria are adopted, once the PROWG preamble is available for review, stakeholders will recognize the importance of considering roughness in pathway compliance, and need a way to measure it. In order to evaluate pedestrian pathways in an objective manner, a device that measures surface roughness and the other accessibility characteristics is required. Although devices designed to measure the roughness of roads and highways exist, they have insufficient accuracy for measuring walkways. These devices, being designed for cars, typically measure surface profiles at a minimum resolution of 1 inch along the route of travel. In contrast, the smaller wheels of wheelchairs are more sensitive to minor surface imperfections necessitating a more accurate profile measurement.

**Measurement Devices**

Roughness is calculated from a longitudinal profile along a wheel path of the surface. There are several methods of capturing these profiles including the rod and level, dipstick, profilometer, rolling profilers, and inertial profilers. Table 1 shows the advantages and disadvantages of adapting each measurement system to sidewalks and wheelchair pathways.

**Table 1: Advantages and Disadvantages of Measurement Devices and Techniques [15]**

Measure Device	Measurement Process	Advantage	Disadvantage
Rod and Level	Inclinometer and Laser	Simple, Extremely accurate	Slow process
Dipstick	Inclinometer	Simple, Very accurate, Low cost	Short profiles, slow process
Profilometer	Profilograph	Cost effective, Faster	Wide variation in

		measures	response properties, Only measures certain wavelengths
Inertial Profiler	Accelerations and Displacements	Can be mounted to any vehicle	Expensive, Requires a certain amount of speed to work

Another method to evaluate roadway surfaces is the Present Serviceability Index (PSI), which is the most commonly used method for subjectively measuring surface condition based on perception of serviceability. The primary use of PSI is to evaluate the ability of the pavement to serve its users by providing safe and smooth driving surfaces. This method involves a group of panelists riding in a car over the roadways and filling out a PSR (Present Serviceability Rating) form. PSI is considered the strongest and most accurate evaluation of a road surface because of the attention to detail; however, it requires a substantial amount of labor-hours and other associated cost.[15-17]

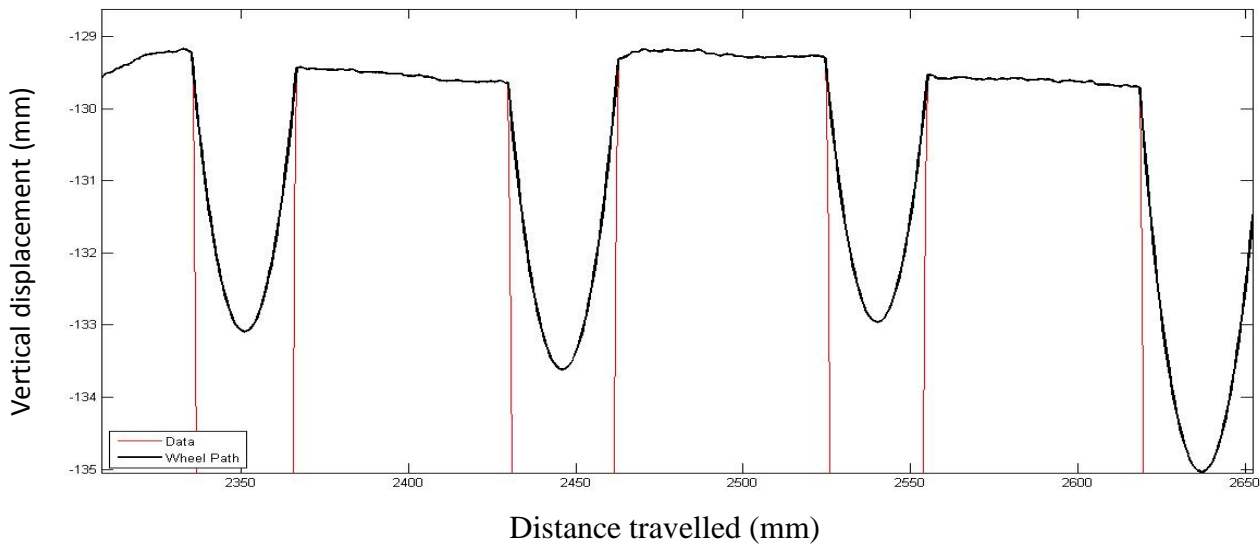
### **Analysis Technique**

There are also many ways to characterize surface parameters based on these profiles. These include the International Roughness Index (IRI), Power Spectral Density (PSD), and Wavelet Theory (WT). The technique used to calculate the roughness of a pedestrian pathway surface is similar to the International Roughness Index (IRI). ASTM E1926, *Standard Practice for Computing International Roughness Index of Roads from Longitudinal Profile Measurements*, [18] reports that IRI roughness data for roadways is used by local, state and federal agencies in pavement management systems. In addition, IRI is used by the U.S. Federal Highway Administration (FHWA) as the input to their Highway Performance Monitoring System (HPMS). [15] For this reason, the key aspects of the IRI are utilized for analysis since it is a widely accepted measurement of roughness. IRI is calculated as the sum of vertical deviations normalized by the horizontal distance travelled (i.e. inches/mile). For pathways, the Surface Roughness Index (SRI) has been defined as the sum of vertical displacements of a wheel normalized by the distance traveled. [13] The calculation of SRI is based on the wheel-path of a 2.5” wheel traveling over the surface, which acts as a low-pass filter to the raw longitudinal profile data. This wheel size was chosen because it is the smallest and a highly common wheel found on manual wheelchairs. Figure 3



shows this path as the 2.5-inch wheel travels across gaps within a surface profile. The SRI of a surface is reported in units of inches per foot.

As the number of wheelchair users in the United States increases each year, it is important to reduce the number of uneven pathways that cause harmful whole-body vibrations to these Americans. The upcoming development of the surface roughness standard and the accompanying analysis technique for measuring surface profiles creates a need for a commercially available product capable of determining pathway roughness in a community setting. The following paper describes the design, fabrication, and testing of PathMeT, developed for the purpose of measuring pathway accessibility characteristics.



**Figure 3: Graph of wheel-path analysis to determine SRI**

## METHODS

### Goals

The goal of this project was to develop a tool that could characterize the accessibility of pedestrian pathways based on the following parameters: flatness, running slope, cross slope, level change, and roughness. The design is targeted for all stakeholders involved in designing, constructing, and evaluating pedestrian pathways. The following were the design objectives (Table 2):

**Table 2: Original design objectives and specifications**

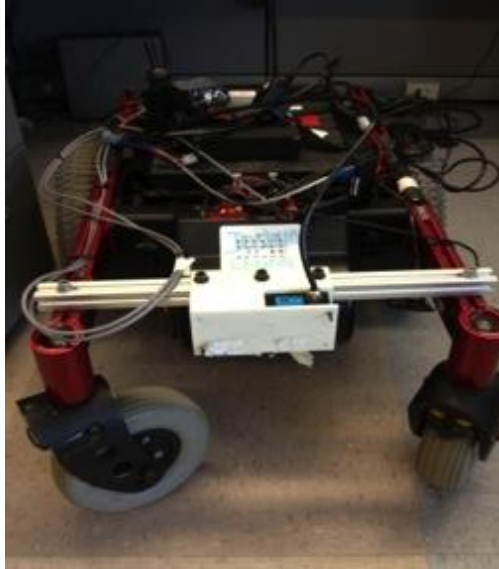
Objectives
------------

1. Measure surface roughness accurately and quickly
2. Measure pathway profiles with 1mm resolution or better.
3. Fit inside the trunk of a typical automobile for easy transport
4. Compatible with ProVAL and other surface analysis software
5. Capable of recording the specific measurements required for surface compliance with ADA Accessibility Guidelines, including cross slope, running slope, and level change
6. Capable of operating for the duration of a typical work day on a single charge of its battery
7. Measure surfaces consistently

### **P1 and P2 Prototypes**

Two initial proof-of-concept prototypes were developed by using two sensors to determine the profiles of surfaces: an Acuity AR700 laser displacement measurement tool and an optical incremental encoder. The laser collected distance measurements by using a single point laser beam and a triangulation technique to geometrically determine the distance from the laser device to the ground surface. In addition, two gears, one attached to the encoder and one to the wheel hub, enabled the encoder to collect data determining the distance travelled by PathMeT.

The first prototype, P1 (Figure 4), which was supported by funding from the Access Board and developed from the base of a power wheelchair, was used in the research to develop the proposed roughness criteria [12]. P1 was a robotic system that was controlled by a joystick. When collecting profile data, P1 was driven over two “tracks” (parallel pieces of plywood) allowing travel over a flat surface. This ensured that measurements were unbiased by the wheels traversing rough terrain. P1 was used as a starting point for the development of the next prototype, P2, which was supported by ICPI/BIA.



**Figure 4: P1 made from a power wheelchair base**

The chassis of P2 (Figure 5), the second prototype, was taken from a jogging baby stroller since jogging strollers are designed to be pushed over sidewalks at a fast pace while eliminating vibrations. The frame was adapted to include enclosures for the laser and encoder. It is a manually propelled device with the wheels inflated to 60 psi in order to reduce the deformation of the tires while travelling over cracks and imperfections. Two different data collection methods were utilized: driving directly over surfaces and driving over plywood tracks, similar to the method for P1. Users refrained from pushing down on the stroller handle to prevent any bias that could occur from the front wheel lifting off the ground.



**Figure 5: P2 made from a jogging stroller**

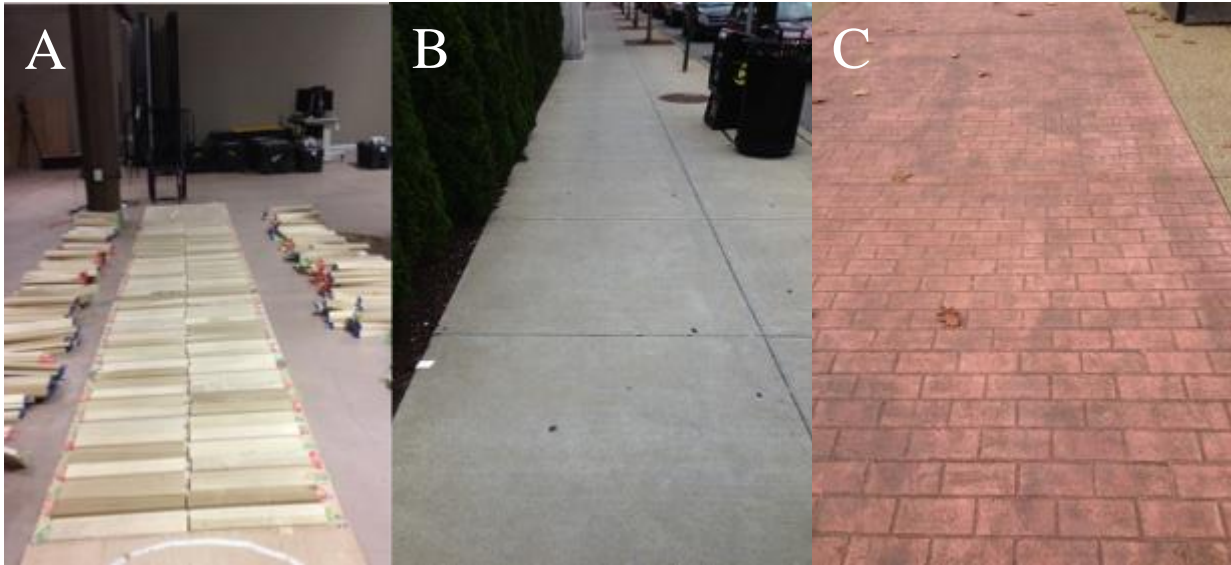
After collecting pilot roughness data with P1 and P2, the laser and encoder were deemed appropriate sensors to use with future prototypes. Although P1 was user-friendly because of the joystick capabilities, a robotic system was not developed due to expense. The jogging stroller was the primary influence for the final design. The three-wheeled rolling system is easy to manually propel. The size of the wheels assists in reducing vibrations, although solid tires are preferred. These specifications are the foundation of the next design. Additional target specifications (Table 3) are provided here:

**Table 3: PathMeT target specifications**

<b>Target Specifications</b>
1. Target Weight (Disassembled): 50 pounds
2. Target Weight (Assembled): 65 pounds
3. Target Physical Dimensions (Disassembled with push-handle collapsed): 40”L x 25”W x 20”H
4. Target Physical Dimensions (Assembled): 60”L x 25”W x 48”H
5. Battery Life: 8 hours

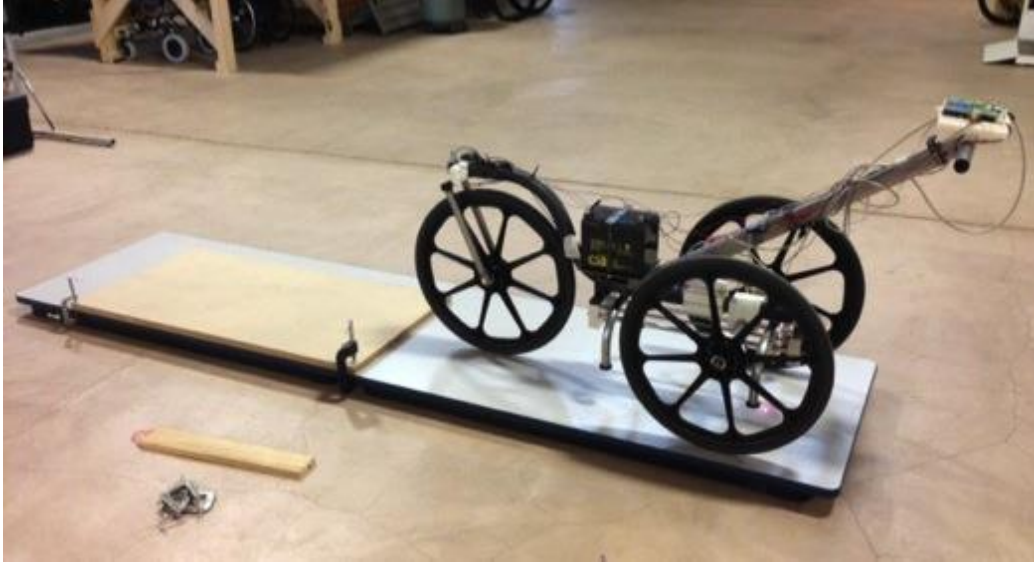
### **Reliability Testing**

Figure 6 shows the three different surfaces measured during reliability testing and characterization of PathMeT. Surface A is a 16 x 4 foot engineered surface comprised of two rows of pieces of ¾-inch poplar hardwood. The 24 pieces in each row are arranged so that there is a 1.25-inch gap every eight inches. Surface B and Surface C are a typical concrete and stamped concrete surfaces respectively. A 16-foot segment of data was collected along Surfaces B and C so that it would compare with Surface A for reliability testing.

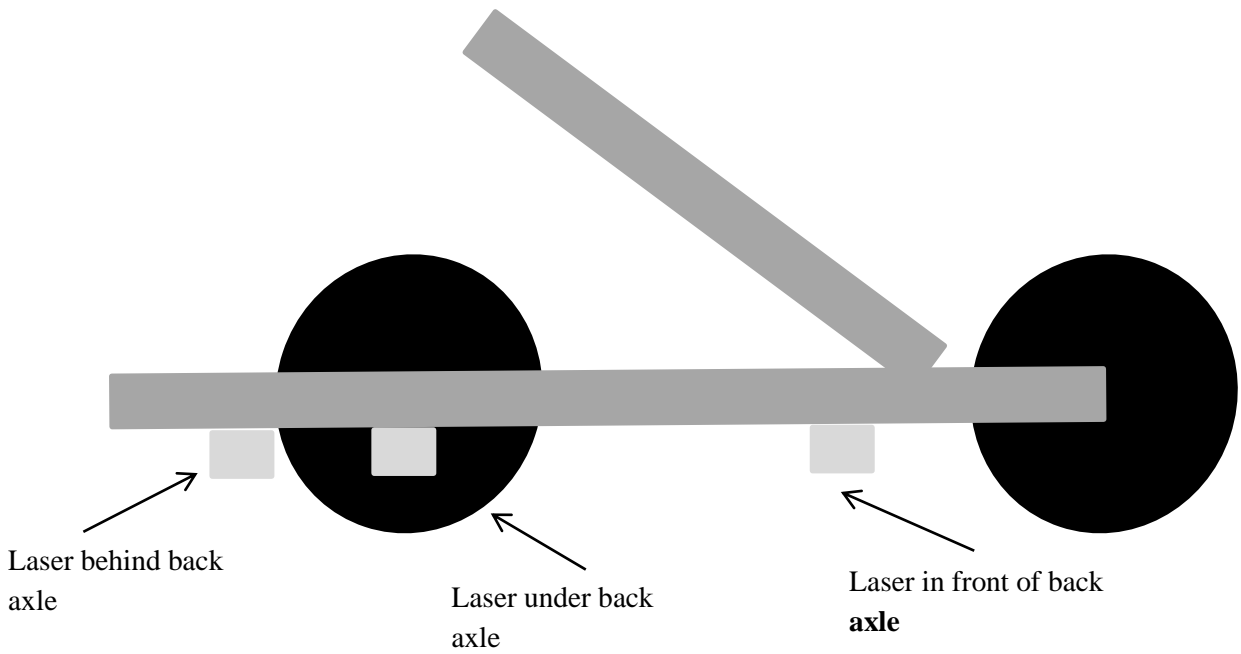


**Figure 6: Surfaces used for testing and characterization of PathMeT (A) engineered surface (B) concrete surface (C) stamped concrete surface**

The reliability testing protocol consisted of two phases: 1) intra- and inter-rater reliability, and 2) level change characterization. In order to test for inter- and intra-rater reliability, three individuals propelled PathMeT over Surfaces 1, 2, and 3. For each surface, the user propelled PathMeT along three different paths. Level change characterization consisted of one user propelling PathMeT three times up and down steps of  $\frac{1}{4}$ -,  $\frac{1}{2}$ -,  $\frac{3}{4}$ -, and 1-inch. The steps were comprised of 2 x 4 foot sheets of  $\frac{1}{4}$ -inch thick MDF board placed above collapsed tabletops to provide a solid level surface. Figure 7 shows this testing assembly. Additional testing was conducted to observe the effect of laser placement on surface profiles. Figure 8 shows the three laser placements considered: behind, under, and in front of the back axle.



**Figure 7: Level change characterization setup**



**Figure 8: Three different locations of laser for level change testing**

## Community-based Data Collection

Data was collected at ten different locations. PathMeT was manually propelled at approximately 1.0 m/s by a user who walked behind the system. Only Rolling Mode (discussed below) was used during data collection. The user surveyed each surface by measuring three paths, all of which exceeded 100 feet in length. The surfaces varied in design, including poured concrete, rolled asphalt, and concrete and clay pavers. After data collection was complete, the SRI was calculated for each path along a specific surface, and the three SRIs were averaged to get the final SRI for that surface.

## RESULTS

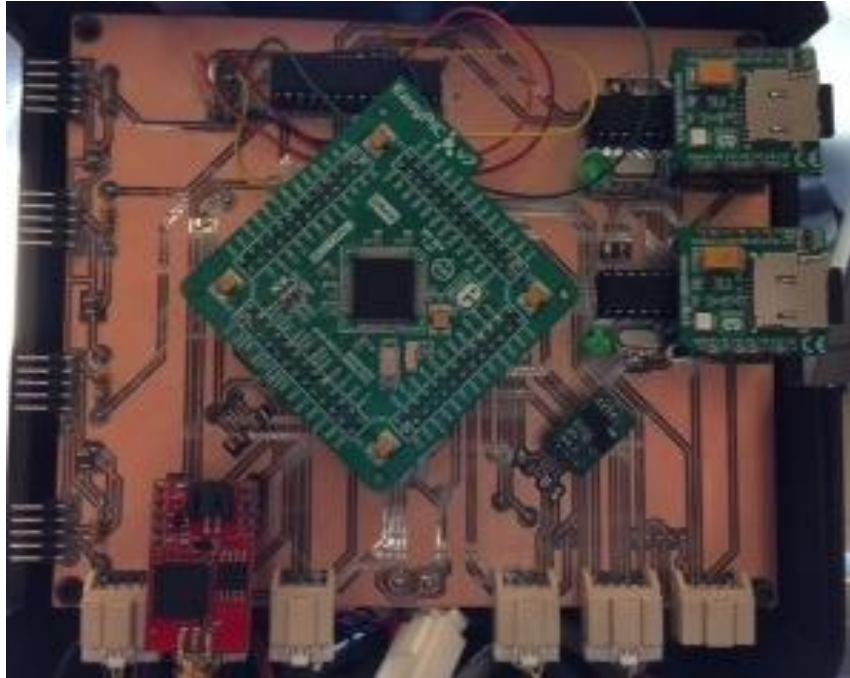
### Electronics Design

PathMeT is composed of numerous sensors (Table 4) integrated into one embedded design. Two of the sensors include a Riftek RF603 laser displacement measurement tool capable of measuring up to 9.4 kHz and an S5 optical shaft encoder. The laser device is pointed perpendicular to the ground and, using a triangulation technique and trigonometry, measures the distance to the ground. The encoder measures the distance travelled by PathMeT. Together, the laser and encoder data provide a profile of the measured surface.

**Table 4: List of PathMeT sensors**

Sensor	Manufacturer/Model
Laser	Riftek RF603
Encoder	US Digital S5 Optical Shaft Encoder, S5-360-250-IE-S-B
Inclinometer	US Digital X3M Multi-Axis Absolute MEMS Inclinometer
Accelerometer	Freescale MMA7260Q
Camera	RobotShop Color JPEG Camera w/ Infrared, RB-Lin-48
GPS	Sparkfun Venus GPS Logger

All sensors are integrated into a customized electronics board (Figure 9) in order to collect data. Figure 10 & Figure 11 show schematics of the sensor layout and the associated connections. There is a thin-film-transistor (TFT) touchscreen display that acts as the interface between the user and the sensors. The TFT displays a graph of the profile during data collection for real-time feedback. Data processing is done through the use of two dsPIC33EP512MU810 microcontrollers, and two microSD cards are used for data collection.



**Figure 9: PathMeT printed circuit board**



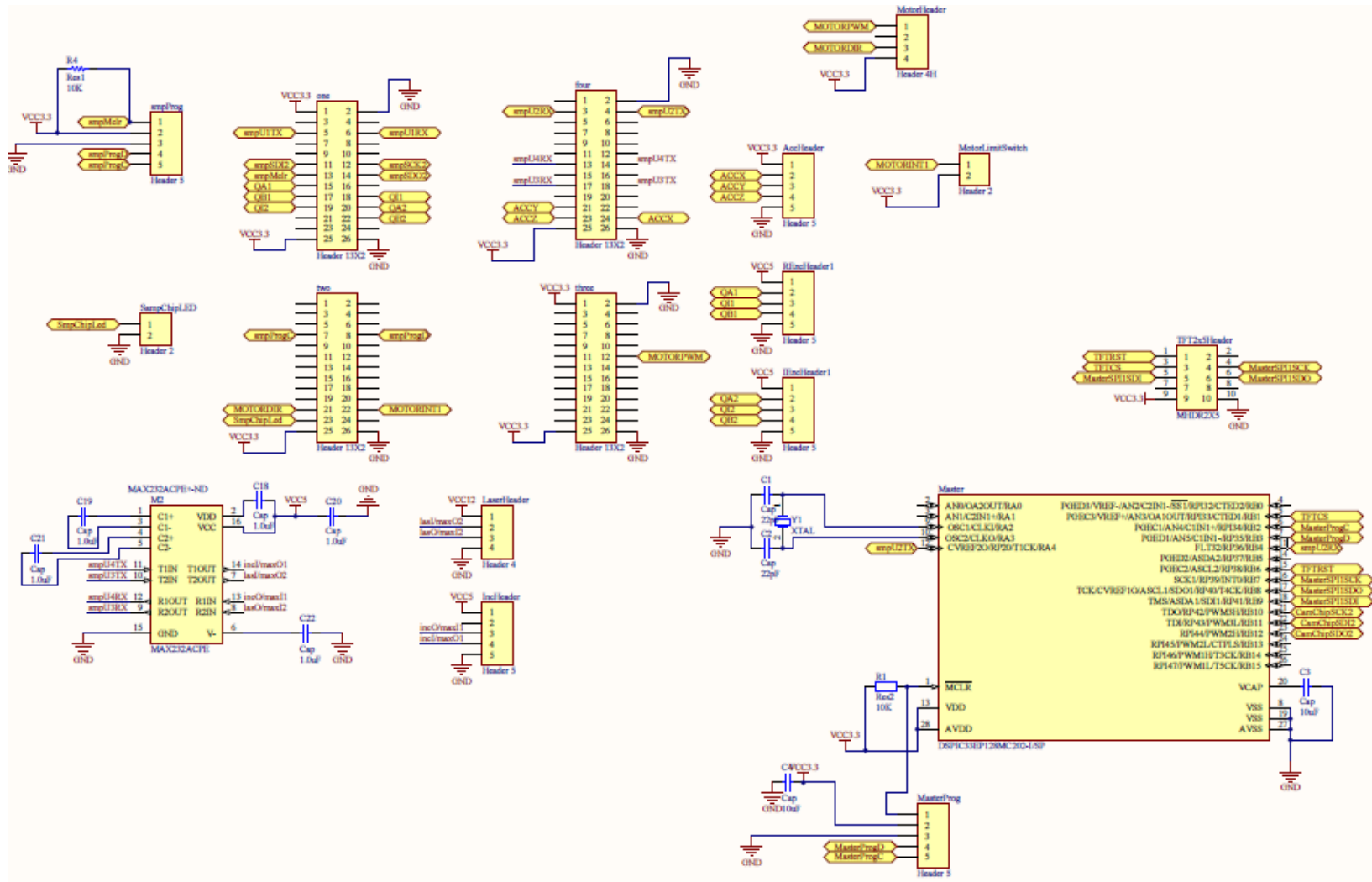


Figure 10: Schematic of PathMeT electronics and sensors

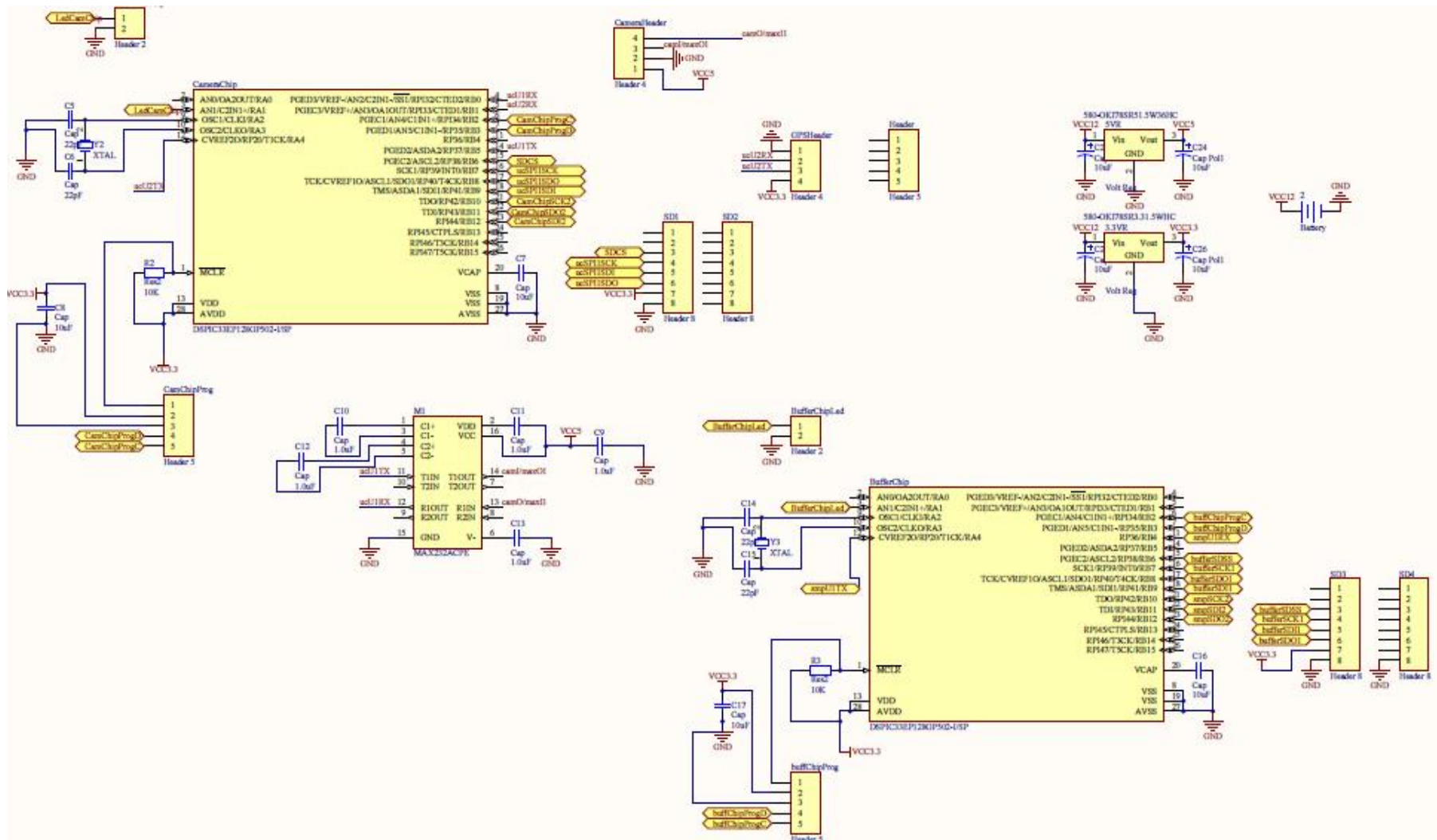
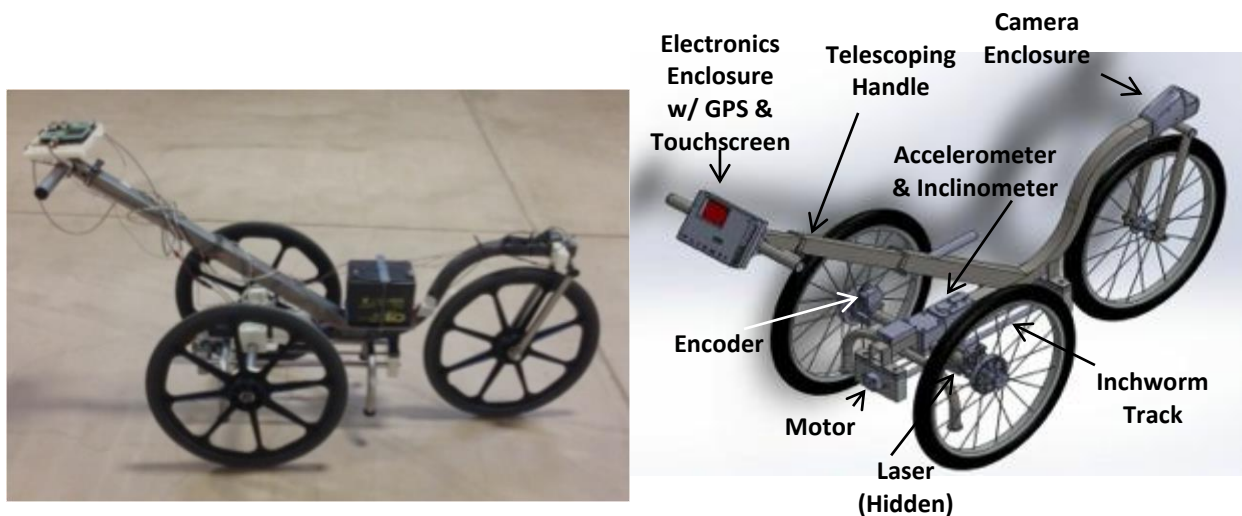


Figure 11: Schematic of PathMeT electronics and sensors

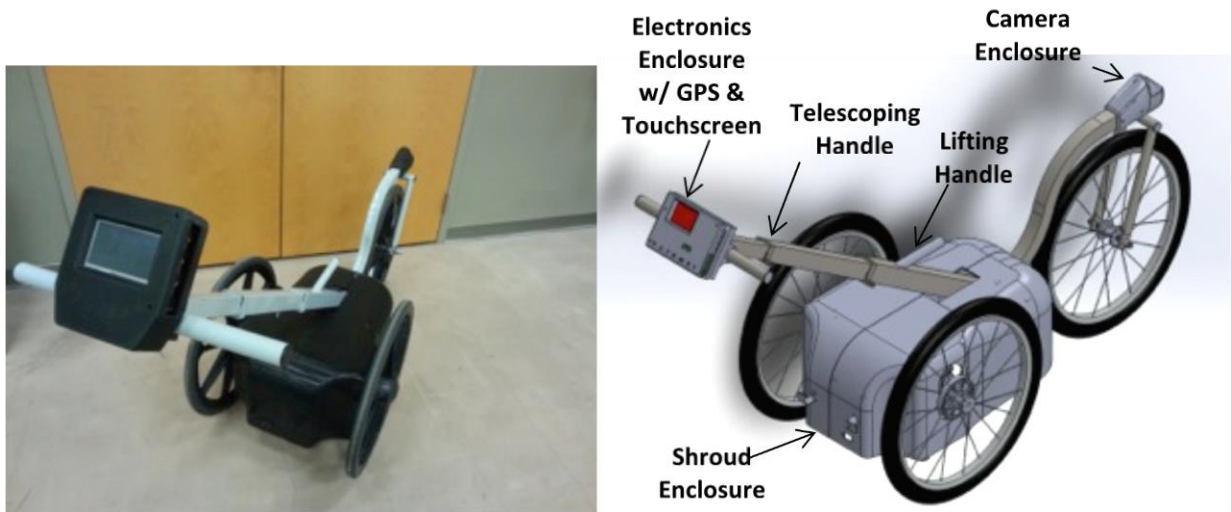
Data is collected via serial communication between the microcontrollers and the sensors. The microcontrollers collect one byte of data at a time, alternating between the laser and encoder. This ensures that all data is collected by a one-to-one ratio between the two sensors. A time stamp is recorded with every byte to ensure accurate timing. The microcontroller collects on average, but no less than, one laser and encoder reading every millisecond. This is based on a speed of  $1.0 \text{ m/s} \pm 10\%$ , which is recommended propulsion speed. This speed was selected as a common walking speed and also the average speed of wheelchair users. [9, 10] If more than one reading per millisecond is recorded, the data is down sampled by averaging the numbers for that specific millisecond. Therefore, the data is collected at 1000Hz sampling rate, resulting in 1mm resolution.

## Mechanical Design



**Figure 12: Pictures of the inside of PathMeT**




The mechanical design of PathMeT, shown in Figure 12, includes a square tube steel frame with three 22-inch solid wheelchair tires. Solid tires were selected to eliminate sources of error that might be experienced with pneumatic tires through a variation in tire pressure. The front wheel is a caster, allowing for PathMeT to make turns easily. All three wheels can be quickly removed for increased portability. Furthermore, a twice-telescoping adjustable handle bar extends out to the user for increased comfort. Figure 13 shows a completed PathMeT with enclosures included.



**Figure 13: Pictures of PathMeT**

This three-wheeled rolling design was selected in order to ensure that the device was easy to propel over an uneven surface. A second design concept considered was a tracked system. This system would be beneficial because it would eliminate errors experienced by traversing rough terrain with wheels. However, this treaded tracked system would need to be a robotic system since it would be difficult to propel with tracks, which would increase costs. The advantage of the long railway track would be its ability to completely eliminate errors caused by wheels since the track would be stationary on the ground. In addition, data would be collected in one long pass over the surface. Table 5 shows a comparison of the pros and cons of the three methods. However, the time and effort needed to set up this design does not make it user-friendly. Therefore, a user-friendly rolling device was designed to improve speed, while maintaining accuracy and keeping costs low. This method of data collection is referred to as Rolling Mode (Figure 14).

**Table 5: Pros and cons of data collection methods**

	<b>Method</b>	<b>Pros</b>	<b>Cons</b>
<b>Wheeled</b>		<ul style="list-style-type: none"> <li>- Quick data collection</li> <li>- Inexpensive</li> </ul>	<ul style="list-style-type: none"> <li>- Some error due to a smaller area that makes contact with surface</li> </ul>
<b>Tracked</b>		<ul style="list-style-type: none"> <li>- Autonomous robot</li> <li>- Tracks reduce error due to a larger area that makes contact with surface</li> </ul>	<ul style="list-style-type: none"> <li>- Expensive</li> </ul>
<b>Railed</b>		<ul style="list-style-type: none"> <li>- Eliminates error due to contact with surface</li> </ul>	<ul style="list-style-type: none"> <li>- Time consuming compared with Wheeled and Tracked methods</li> </ul>

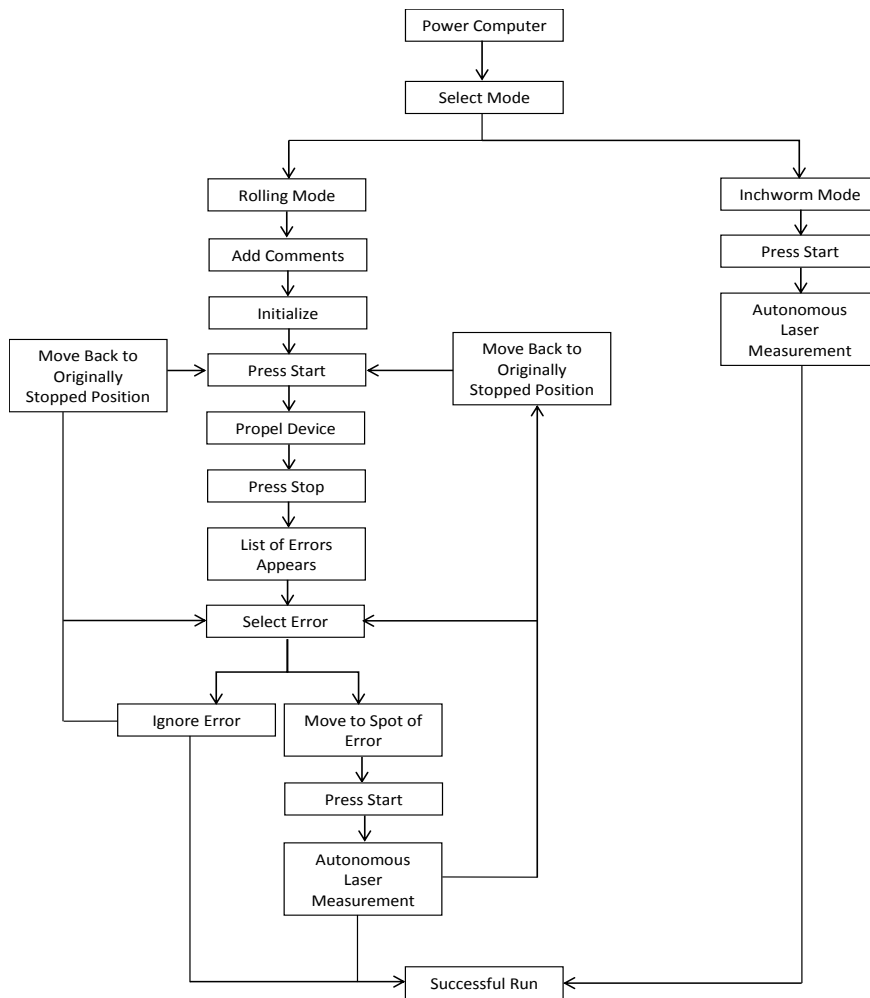


**Figure 14: Data collection during Rolling Mode**

### **Rolling Mode**

Rolling Mode allows the user to push PathMeT continuously at a speed of  $1.0 \text{ m/s} \pm 10\%$ . This speed has been chosen in order to ensure 1mm resolution and to be consistent with typical walking and wheelchair speeds. This mode allows for a large amount of data to be collected in a relatively short period of time. While data is continuously collected in Rolling Mode, the user is alerted of pathway segments that either are not in compliance with the roughness criteria or that result in data errors. Data from these segments is then recollected using the Inchworm Mode outlined below. When PathMeT is stopped, each rough segment is displayed in a queue. The queue displays the distance the user must backtrack in order to recollect the data for each segment. The user can either decide to recollect the data or ignore the error.

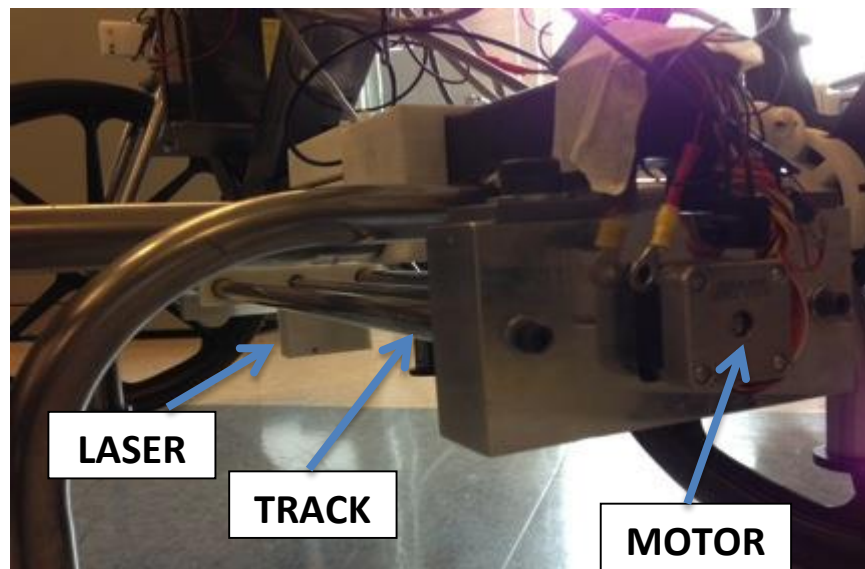
Figure 15 shows a flow chart for operation within the Rolling Mode. If the user decides to recollect data for rough segments, he/she will backtrack the original path travelled. As the user moves backwards, the odometer counts down until it reads “0 ft.” for the first error listed. The errors are ordered from newest to oldest. The user then applies the brake and initiates the Inchworm Mode (discussed below). Once Inchworm Mode is completed for that location, the user moves to the next flagged location. The user has the option to ignore the next flagged spot, measure it, or return to Rolling Mode. This process is repeated for each segment that displayed an error in the queue.



**Figure 15: Flow chart of user operation within each mode**

## Inchworm Mode

PathMeT has the ability to collect data via a method referred to as Inchworm Mode. In Inchworm Mode, PathMeT remains stationary after the user places it over the area of the surface where data is to be collected. While Inchworm Mode is engaged, the user holds PathMeT stable, although in future versions a brake will be implemented to avoid any user error (accidentally moving PathMeT while Inchworm Mode is engaged). The user presses a button to begin data collection, and PathMeT's motor-driven laser moves along a 20 inch track collecting data for the area of the surface immediately below it (Figure 16).



**Figure 16: Inchworm assembly**

For example, consider a 10-ft length of surface that needs to be measured. In order to collect data using Rolling Mode, the user would manually propel PathMeT for a total of ten feet and data collection would be complete. To collect the same data in Inchworm Mode, the user would need to position PathMeT for six successive measurements since the laser only moves on a 20 inch long track. Thus, the user would place PathMeT over the first 20 inches of the 10-ft section, hold PathMeT stationary while that 20 inch section is measured, then place PathMeT over the next 20 inch section and repeat until data for all ten feet of the pathway is collected.



## PathMeT Specifications

Table 6 shows a list of the final specifications for the latest PathMeT design.

**Table 6: PathMeT specifications**






PathMeT Specifications
1. Weight (Disassembled without wheels): 69 pounds
2. Target Weight (Assembled): 84 pounds
3. Physical Dimensions, inches (Disassembled with push-handle collapsed): 46.5 L x 18 W x 23 H
4. Physical Dimensions, inches (Assembled): 75.5 L x 23.5 W x 42.5 H
5. Battery Life: Undetermined

## Comparison with Existing Technology

PathMeT differs in multiple ways from other surface measurement instruments currently available. PathMeT is capable of gathering data while in motion or stationary, a feature not shared by other devices. These two data collection modes are referred to as Rolling Mode and Inchworm Mode respectively. Rolling Mode allows the user to gather data while propelling PathMeT over a surface. If sections of the pathway being measured become too uneven or produce errors in the collection process, Inchworm Mode can be utilized to continue collection. During Inchworm Mode, the laser moves automatically along a 20-inch track while the PathMeT device remains stationary. Concerning precision, other devices such as the SurPRO 3500 can only measure longitudinal profiles with 6mm resolution. PathMeT is an all-in-one package, measuring cross slope, running slope, level change, roughness (1mm resolution), and obtaining GPS location and a photograph.

Table 7 compares PathMeT with three other surface assessment devices. The SurPRO is an inertial profiler that measures roadway roughness. The ULIPs (Ultra Light Inertial Profiler for Sidewalks) is a modified Segway that measures some pathway characteristics. However, the ULIPs costs an estimated \$120,000. [19] PathMeT is significantly less expensive than this, selling for approximately one third of this price. Devices by Beneficial Designs are capable of measuring pathway characteristics, but three devices are needed to make all the measurements made by PathMeT.

**Table 7: Comparison matrix with other products**

	 <b>PathMeT</b>	 <b>ULIPs</b>	 <b>Beneficial Designs</b>	 <b>SurPRO</b>	 <b>Level &amp; Tape Measure</b>
<b>Sidewalk Roughness</b>	Automated	No (Texture Only)	No	No (6mm Resolution)	No
<b>GPS Location</b>	Automated	Manual	Automated	No	No
<b>Picture</b>	Automated	Automated	Automated	No	No
<b>Level Change</b>	Automated	Automated	Manual	No	Manual
<b>Running Slope</b>	Automated	Automated	Automated	No	Manual
<b>Cross Slope</b>	Automated	Automated	Automated	No	Manual
<b>Width</b>	Automated	No	Manual	No	Manual

### **Interface Design**

Figure 17 shows the user interface for PathMeT and the step-by-step process for data collection. Step 1 shows the display upon powering the device. When ready, the user presses the “Initialize” button to initialize the system. Step 2 shows the loading bar after Step 1. This loading screen takes twenty seconds, allowing the laser to warm up and initialize. Step 3 shows that the system is waiting for a command. When ready, the user presses “Start sampling” to ensure that all the sensors are sampling properly. Step 4 shows PathMeT in “sampling mode”. In order to progress, the user first selects “Stop sampling,” then “Logging Mode.” Before data can be collected, the user creates a folder in which to save data for that specific data collection run. The user does this by selecting “Create a Folder” (Step 5), entering a file name up to six characters and pressing “Confirm.” Data collection begins in Step 7 when the user selects either Rolling Mode (RL) (shown in the picture) or Inchworm Mode (IW), presses “Start Profiling” and begins propelling the device, if in Rolling Mode. Step 8 shows the four instantaneous outputs that are displayed: A) Running Slope, B) Profile of the surface, C) Speed, D) Cross Slope. When

the user is propelling PathMeT at an appropriate speed, the speedometer is green; otherwise, the speedometer is red. When data collection is complete, the user presses the “Stop Profiling” button. Step 9 shows that the camera must finish transferring data before proceeding to the next run. Finally, Step 10 shows a summary of the run, including time elapsed, distance travelled, file name, last instantaneous speed, and average speed. The user can then select “new profile” to begin a new run, “About” to learn about the previous run, or “Help” for help in proceeding. These are the steps required for data collection.

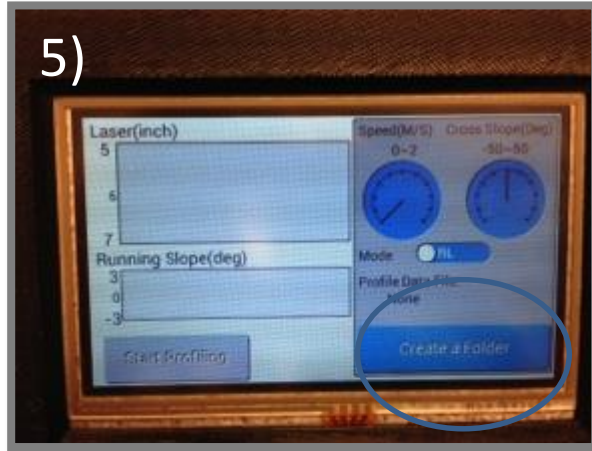
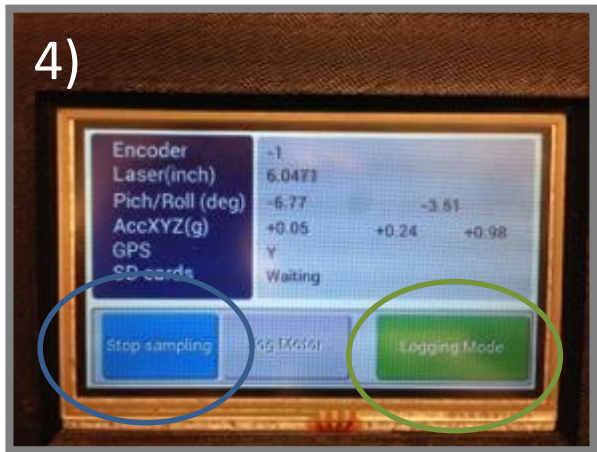
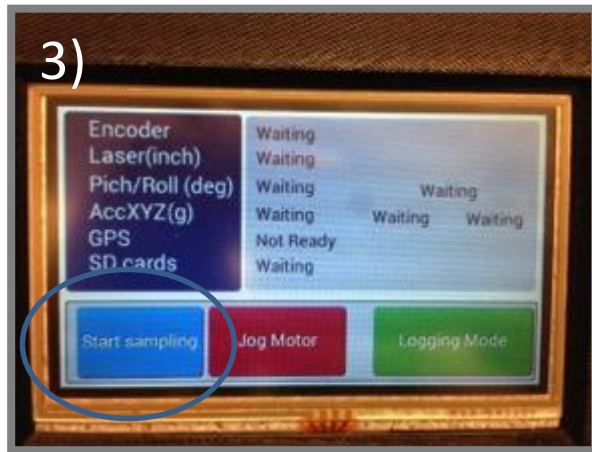
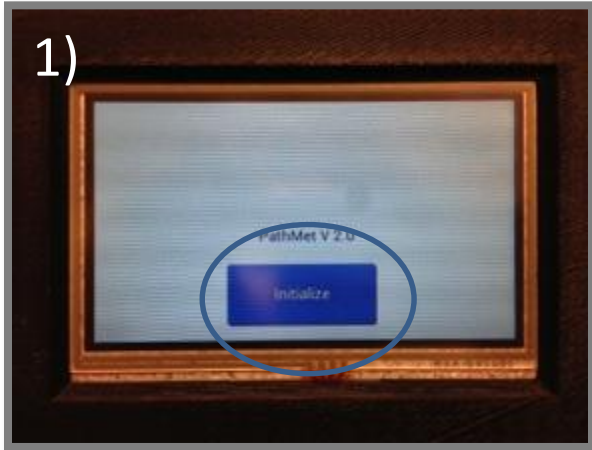
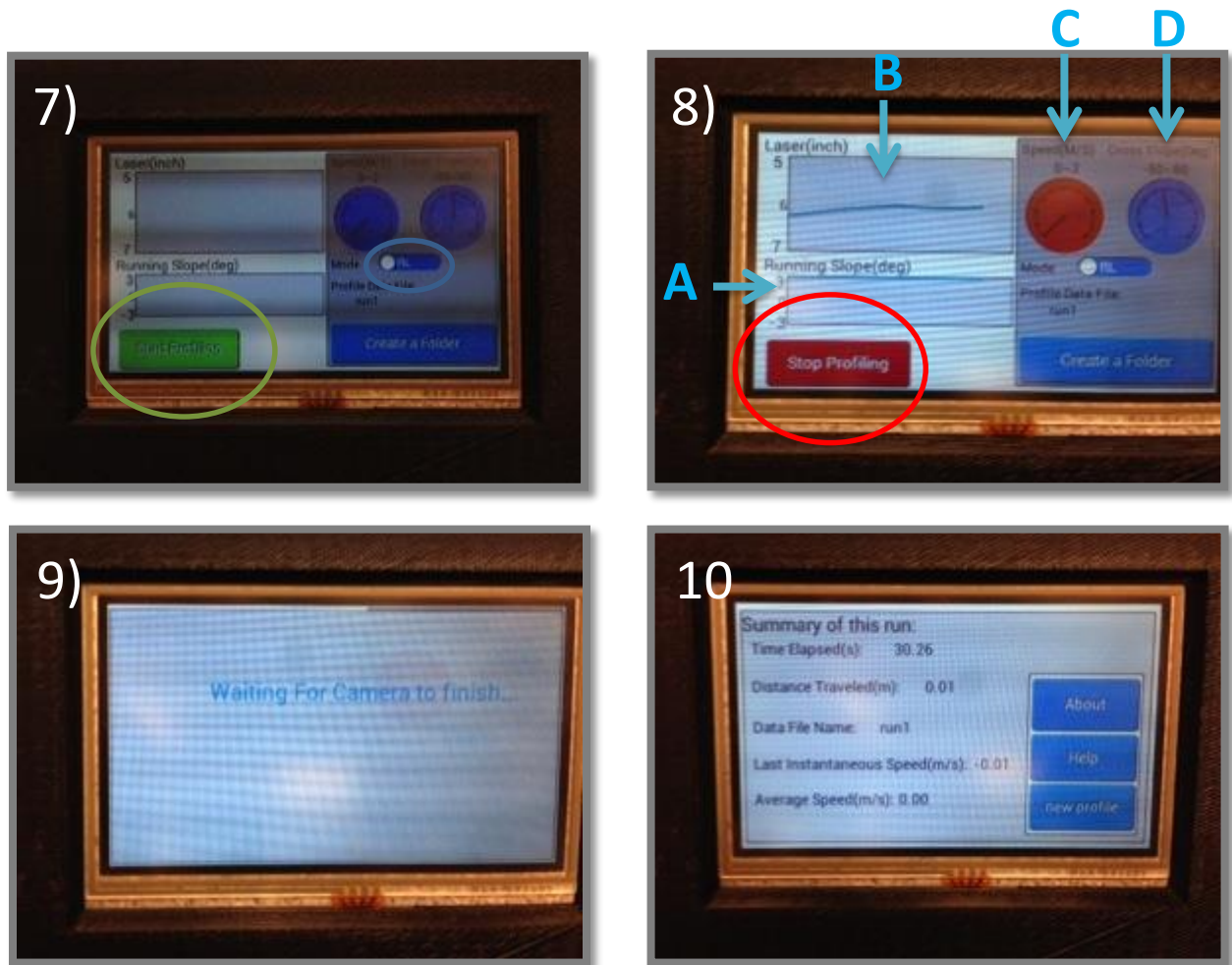


Figure 17: PathMeT interface



**Figure 17 (continued): PathMeT interface**

**Reliability Testing Results**

Table 8 shows the results of the testing protocol for intra- and inter-rater reliability. Each cell represents the average SRI for a particular user on a particular surface. The standard deviation within the trials is also displayed, with Surface 1 showing the largest variance in standard deviation between users. After performing IBM SPSS Statistics analysis for intraclass correlation, results show a .993 intraclass correlation of average measures with a 95% confidence interval of [0.976, 0.998]. Similar analysis shows a 0.979 intraclass correlation of single measures with a 95% confidence interval of [0.932, 0.995]. In addition, an inter-item correlation results in a 0.983 mean with 0.976 and 0.997 minimum and maximum values, respectively. Finally, SPSS analysis presents Cronbach’s alpha equal to 0.993.

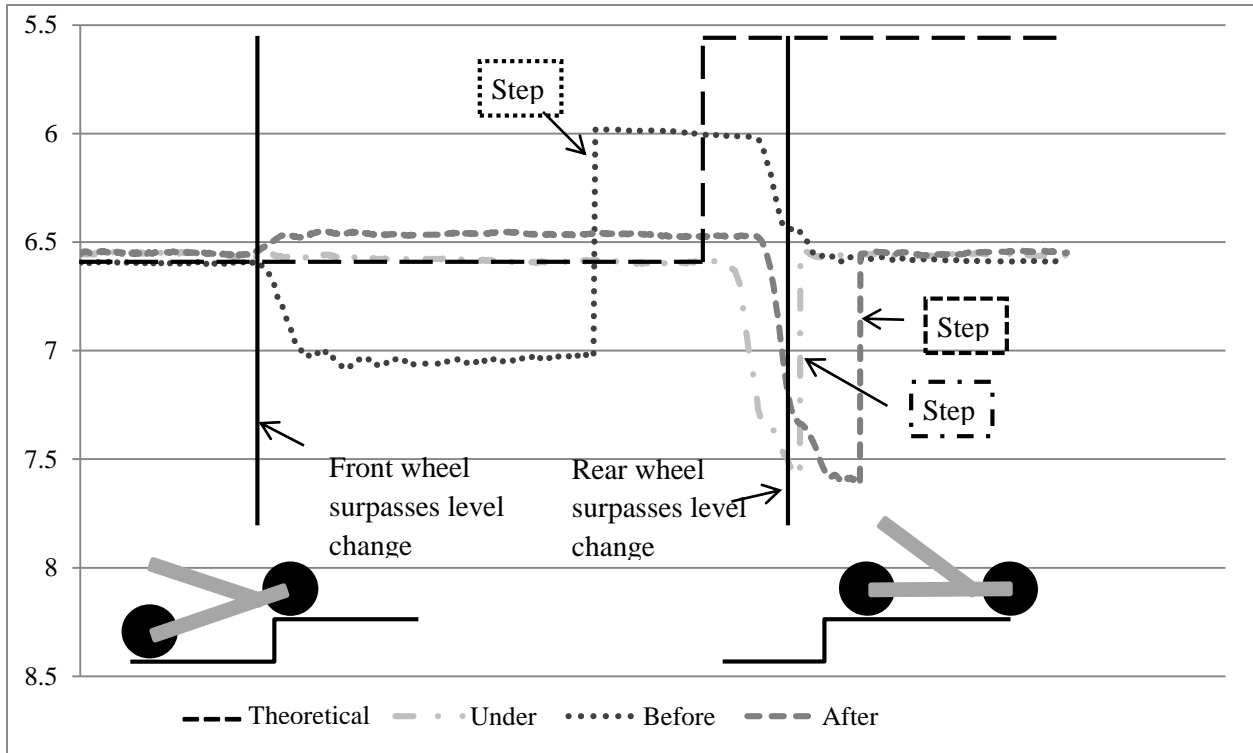
**Table 8: Average SRI of Three Surfaces by Three Users**

	User 1 Avg (Std Dev)	User 2 Avg (Std Dev)	User 3 Avg (Std Dev)
<b>Surface 1</b>	0.92 (0.01)	0.99 (0.13)	0.94 (0.06)
<b>Surface 2</b>	0.39 (0.02)	0.39 (0.02)	0.40 (0.04)
<b>Surface 3</b>	0.47 (0.05)	0.46 (0.03)	0.44 (0.04)

Level change testing results, can be seen in Figure 18. The Figure shows the effects of different laser placements when propelling over a one inch step. The line labeled *Theoretical* is the actual profile of the step. The lines labeled *After*, *Under*, and *Before* show profiles of the step when the laser is placed behind, under, and in front of the back axle, respectively.

The *After* plot illustrates that when the front wheel hits the step, the laser moves closer to the ground giving the illusion that there is a small bump. Then, the back wheel reaches the step raising the laser one inch higher than the original starting position. This makes the profile appear as if PathMeT has experienced a gap. However, the laser has not experienced the step until the final vertical line that brings the profile back to its original height.

The plot labeled *Under* shows that this placement similarly affects laser data, when the wheels reach the step. On the other hand, when the laser is placed in front of the axle, the resulting profile makes the position of the one inch step clear. In addition, there are two half-inch steps, one before and after the step, which correspond to the front and back wheel ascending the step.



**Figure 18: Profile results of a 1-inch level change at three laser locations**

### Data Collection Results

PathMeT was used to collect data from a small number of different pedestrian pathway community surfaces. This data represents the attributes of a small sample of individual pathway surfaces. The data does not necessarily represent all surfaces of the particular material or design. All data collection was done in Rolling Mode and the information collected included roughness, level change, GPS location, and photographs. Table 9 shows the SRI of each surface calculated for the entire length of the surface (all surfaces were longer than 100ft). If a surface is fairly uniform, the SRI number should not change much if it was calculated over different lengths. A portion of the Surface 4 profile is shown in Figure 19.





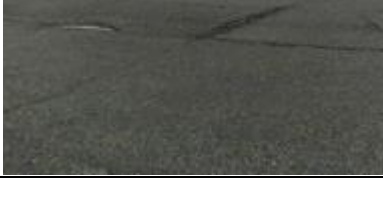
According to the current threshold for roughness proposed to the Access Board, SRI should not exceed 0.6 in/ft for distances of 100 feet or along what would be considered the accessible route. For distances less than 100 feet, the proposed threshold is 1.2 in/ft [14]. Although the method of calculating SRI is the same for all distances, the threshold is lower for longer distances because of the increased risk

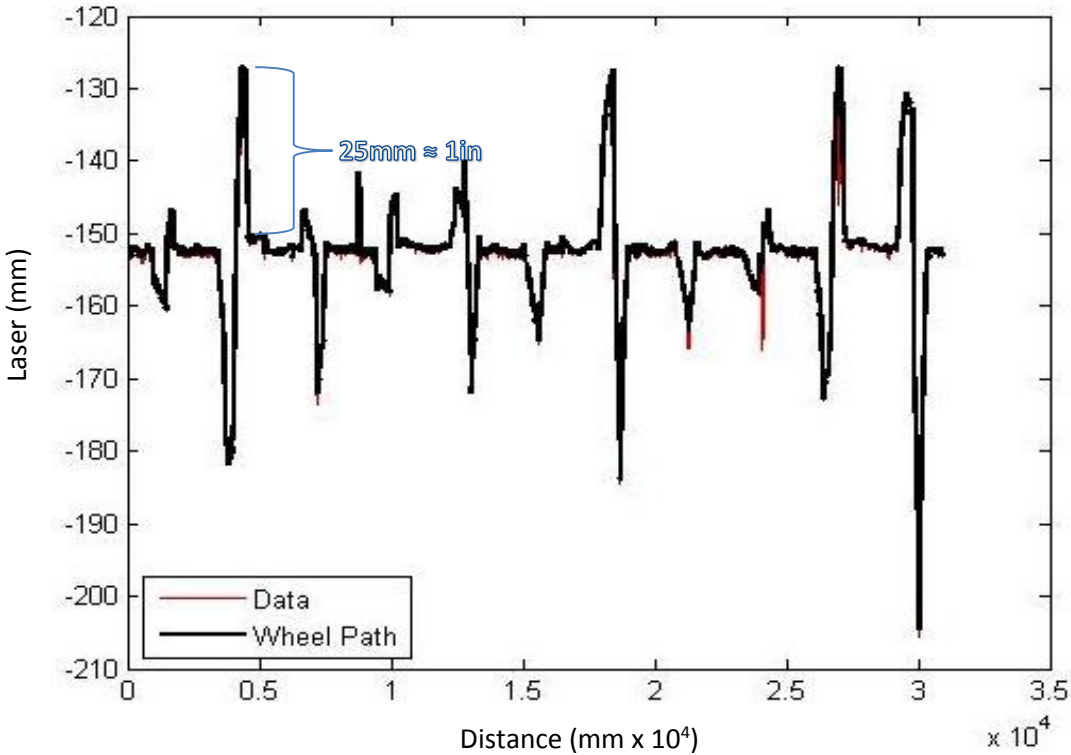
of wheelchair users to vibration exposure from travelling over rough surfaces for a longer period of time. The proposed method to distinguish SRI by varying distances is to have a moving “window” that calculates SRI every 10 feet, then every 100 feet. This would facilitate the distinction between long- and short-range measurements; however, this analysis approach is currently under development and not implemented in the calculations in Table 9.

**Table 9: Tested surfaces with their image and SRI**

Surf #	Picture	SRI (in/ft)
1		0.368
2		0.546
3		0.661
4		0.746
5		0.771

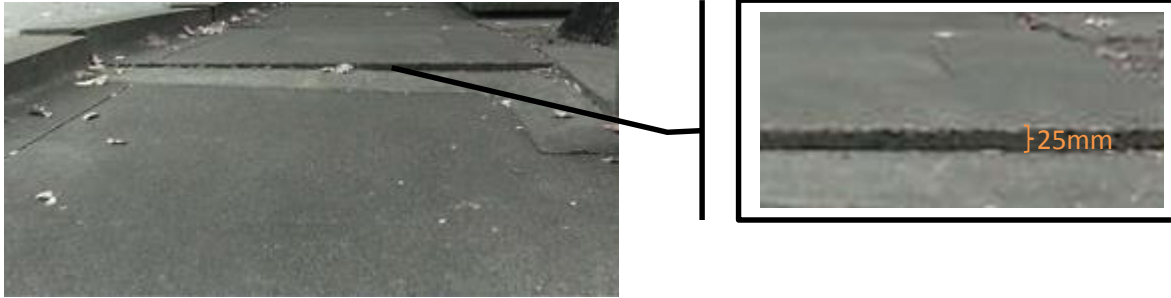


6			0.771
7			0.889
8			0.981
9			0.995
10			1.021



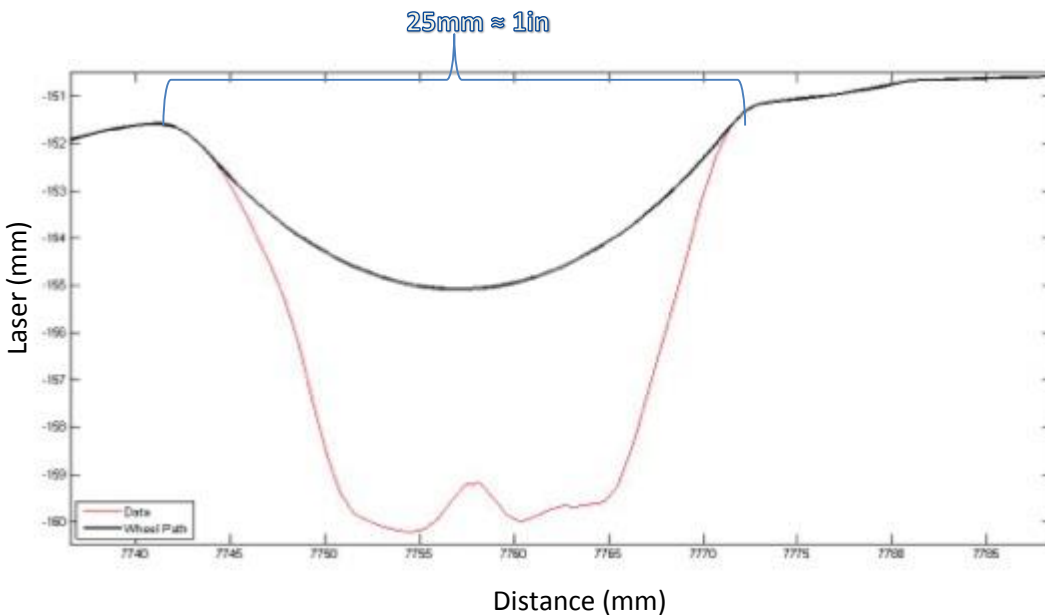
**Figure 19: Profile of Surface 4**

Data collection at Surface 4 resulted in a SRI of 0.746 in/ft, averaged from five repeated runs over the surface. Although the SRI is in the cautioned range, the profile for Surface 4 indicates level changes of approximately one inch at four locations. These changes in level are not acceptable according to the Americans with Disabilities Act Accessibility Guidelines (ADAAG). According to ADAAG, a change in level cannot exceed ¼-in. or ½-in. with a bevel. The one inch change in level means that the surface does not comply with ADAAG at those four specific locations. Figure 20 shows the location where the first noncompliance occurs and correlates with the first spike shown in Figure 19 profile. The level changes do not necessarily provide any other information regarding the level of compliance for the entire surface. However, if there were no other accessible routes, then due to the non-compliant level changes, it would be deemed that there is no accessible route.



**Figure 20: Image of Surface 4 with level change enlarged**

Among the data collected, comparisons between Surfaces 1 and 2 (Table 9) are particularly interesting. Surface 1, made of pavers, has a lower SRI than that of Surface 2, made of poured concrete. This data challenges frequent general assumptions that “continuous” surfaces are smoother than those with joints and shows that when designed, installed and maintained properly, a paver surface can be smoother than a poured concrete surface. This data suggests that roughness is largely due to the size, frequency, and quality of the joints. Figure 21 shows a 1-inch expansion gap from Surface 2, which results in an increase in roughness.



**Figure 21: Enlarged profile of Surface 2 expansion gap**

Comparisons of the SRI of Surfaces 3 and 5 (Table 9) are also noteworthy. These two surfaces are generally composed of the same paver material. However, Surface 5 has concrete slabs mixed in with the pavers. The addition of a second type of material, although concrete, results in rougher surface than one consisting of pavers alone. This shows the importance of ensuring smooth transitions between two dissimilar surfaces. Although both are designated as 'yellow', Surface 5 has a SRI that is 0.1 greater than Surface 3.

Detailed analysis of Surface 8 reveals large gaps between pavers. A profile of the surface is presented in Figure 23a, and an enlarged section of the profile in Figure 23b. Upon further enlargement, Figure 23c shows that the width of one of the gaps is 1 inch. It appears as if a major contributor to the roughness of this surface is the large gap size.



**Figure 22: Close-up of Surface 8**

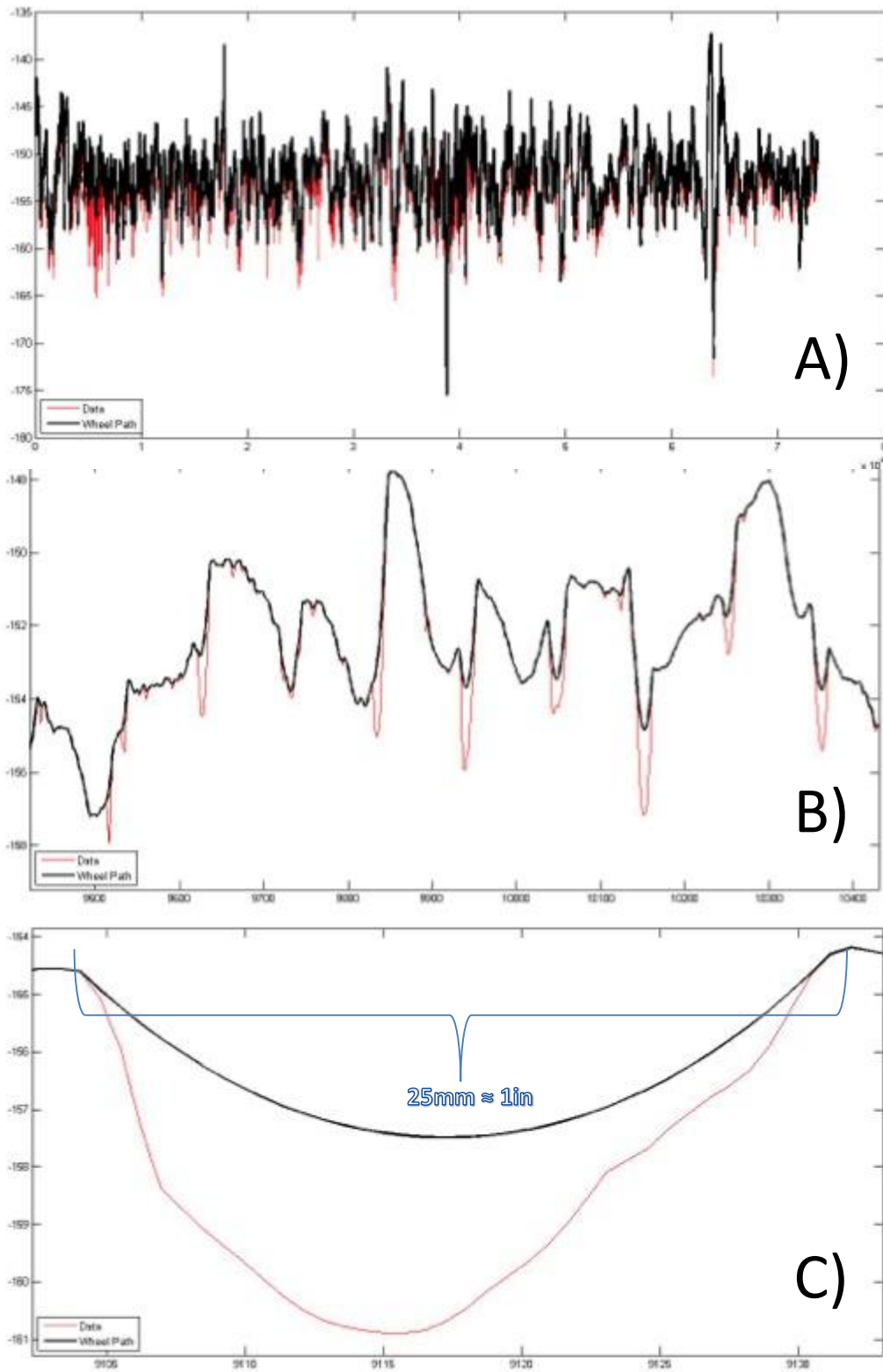


Figure 23: Profiles of Surface 8

Surface 10, the roughest of the surfaces measured, is composed of a broken asphalt surface. Portions of the surface remained intact, but many potholes were observed, causing the increased roughness.

## **DISCUSSION**

PathMeT has ability to measure surface roughness and other characteristics with adequate detail and accuracy to determine whether a new or existing surface is considered accessible, based on compliance thresholds proposed by the Access Board.

The fast sampling rates of the laser and the encoder sensors allow PathMeT to measure with 1mm resolution. The mechanical design also facilitates accurate data collection. The 22-inch non-pneumatic solid foam-filled tires allow PathMeT to roll over large cracks without being affected by crack characteristics. These mechanical design features that reduce the amount of errors in the system will result in fewer filters needed in code.

PathMeT is user-friendly in both electronic and mechanical design. The touchscreen display allows simple, intuitive, interaction with the system. In addition, the graph of the profile during data collection shows the user any extremely rough patches. At these positions, data collection may be repeated to ensure accuracy. In addition, the rolling design improves usability by the ease with which data is collected. The user can collect data in a timely fashion; with an average propulsion speed of 1m/s, the user can measure a mile of surfaces in less than 30 minutes. After data collection, the user can easily transport PathMeT by removing the wheels and collapsing the handle.

Table 10 shows the comparison between the target and current specifications for PathMeT. Although the weight and dimension specifications are not within the target specification range, improvement is possible. The weight is more than anticipated due to the use of steel. For ease in prototyping, steel was used so that it can be welded. The use of aluminum, which was a target specification, would drastically decrease the weight of PathMeT, enhancing its portability. However, testing would be needed to ensure accuracy and reliability of an aluminum frame.

**Table 10: Comparison of target and current PathMeT specifications.**

<b>Characteristic</b>	<b>Target Specifications</b>	<b>Current Specifications</b>
<b>Weight (Disassembled without wheels)</b>	50 pounds	*69 pounds
<b>Weight (Assembled)</b>	65 pounds	*84 pounds
<b>Physical Dimensions, inches (Disassembled with push handle collapsed)</b>	40 L x 25 W x 20 H	**46.5 L x 18 W x 23 H
<b>Dimensions, inches (Assembled)</b>	60 L x 25 W x 48 H	**75.5 L x 23.5 W x 42.5 H
<b>Battery Life</b>	8 hours	***Undetermined

\*Increased weight is due to the PathMeT steel frame for ease of prototype manufacturing. Future frames could be built from aluminum and would bring the weight into the target specifications.

\*\*Collapsibility of the handle limits length and height and will be modified in future designs to bring this within target specifications.

\*\*\*Although battery life has not been tested explicitly, PathMeT collected surface data for 8+ hours for each of 2 days and charged at night. Power loss did not occur during those days, so we believe it meets the target specification of 8 hours.

The results from the intra- and inter-class correlation analysis shows that with a correlation of 0.993 and 0.983, respectively, and a Cronbach’s alpha of 0.993, the use of PathMeT is highly reliable. Furthermore, an intra-class correlation of single measures value of 0.979 is highly valuable, especially since each surface is most likely to be measured by a single user. Both single measures and average measures intra-class correlation results showed a significance of  $p < 0.001$ . Since PathMeT has shown to be highly reliable in terms of measuring these surfaces, further testing can continue without concern about biased results.

Examination of the results from testing for level change indicates that placement of the laser greatly affects the profile. The excess vibrations and errors in the system cause a greater roughness than expected. When the front wheel ascends a step, a certain amount of error is experienced. The same occurs when the back wheel reaches the step. Placement of the laser behind the axle appears to be least desirable since the resulting profile is most difficult to determine when the laser actually ascends the step. Laser placement in front of the axle provides the clearest indication of where the step occurs. However, more testing is recommended to investigate the effects of putting the laser directly under the axle. It is clear that when the laser is directly under the axle, the resulting profile is similar to that of the laser placement behind the axle. Therefore, it may be beneficial to test how the laser reacts when placed at the point where the back wheels first hit the step.

## **CONCLUSIONS**

For the segmental pavement and other pavement industries, the development of PathMeT represents a step forward in pedestrian pavement roughness measurement technology. The SRI (surface roughness index) follows the same logic and measurement approach as that used for years on vehicular pavements and formalized in ASTM standards. PathMeT offers an appropriate ‘scaling down’ for measuring pedestrian surfaces traversed by wheelchairs. Its measurement output can be used to assess acceptable, marginal or unacceptable surfaces traversed by wheelchair users based on criteria from other research by the University of Pittsburgh supported by the U.S. Access Board.

Trial measurements identified some segmental pavement surfaces smoother than a poured concrete surface. The data suggests that roughness is influenced mostly by the collective width, frequency and height of the paver joints. The study demonstrates that wheelchair user comfort is related to the smoothness of the entire measured paver (or other) surface based on a continuous travel distance and height transitions, and not on an individual paver. Therefore, pavers manufactured, installed and maintained in accordance with ICPI and BIA guidelines are appropriate for wheelchair accessible pathways conforming to the SRI recommendations in this report. Specifically, the SRI should not exceed 0.6 in./ft for distances of 100 feet or along what would be considered the accessible route. For distances less than 100 feet, the proposed threshold is 1.2 in./ft. As with all pavements, meeting industry construction tolerances and maintaining them through periodic pavement maintenance is critical to compliance with recommended SRIs in this study.

## **FUTURE WORK**

Future work consists of further testing and characterization of PathMeT. Additional tests include testing how different speeds, light exposure, and weather conditions affect the results. A broader range of surfaces should be tested to ensure consistency of the device. These tests should also be done by moving PathMeT slowly over the surface to ensure the device is not biased by displacements experienced when



PathMeT traverses a bump or crack. In addition, an aluminum frame would lighten the device and make it more user-friendly.

A method to integrate data with municipal sidewalk pavement management systems should be developed. Many municipalities maintain databases indicating street and curb conditions as asset management and maintenance tools, but it is uncommon for sidewalks to be part of this database. Pedestrian pathway accessibility characteristics as part of this database can provide municipalities with a improved sidewalk pavement management. As a result, a municipality will be able to easily develop an asset management plan and budget for managing the condition of its sidewalks. They will have quick access in identifying the most inaccessible and noncompliant areas, making these the top priorities for repair. Sidewalk condition databases can facilitate municipal compliance to new national, state or local standards and regulations. Then cities like Los Angeles and Sacramento mentioned earlier in this report will be able to address inaccessible and hazardous surface before litigation occurs, saving them millions of dollars.

### References

1. *Americans With Disability Act*, in 42 U.S.C.A. 1990.
2. *Americans with Disabilities Act Accessibility Guidelines*, in 36 CFR. 2010.
3. Brault, M., *Americans with disabilities: 2010 (Current Population Reports, P70-131)*. Washington, DC: US Census Bureau. 2012.
4. Census, U.S. *The Older Population in the United States: 2012*. 2012; Available from: <http://www.census.gov/population/age/data/2012.html>.
5. Bloomekatz, A., *Suits could force L.A. to spend huge sums on sidewalk repair*, in *L.A. Times*. 2012.
6. Works, C.o.S.P. *Sidewalks, curbs, and gutters*. March 6, 2014].
7. Boninger, M.L., et al., *Investigating neck pain in wheelchair users*. *Am J Phys Med Rehabil*, 2003. **82**(3): p. 197-202.

8. DiGiovine, C.P., et al., *Whole-body vibration during manual wheelchair propulsion with selected seat cushions and back supports*. IEEE Trans Neural Syst Rehabil Eng, 2003. **11**(3): p. 311-22.
9. Control, C.f.D. *Falls among older adults: an Overview*. 2013; Available from: <http://www.cdc.gov/homeandrecreationalafety/Falls/adultfalls.html>
10. Cooper, R.A., et al., *Driving Characteristics of Electric Powered Wheelchair Users: How Far, Fast, and Often Do People Drive?* Arch Phys Med Rehabil, 2002. **83**(2): p. 250-5.
11. Tolerico, M.L., et al., *Assessing mobility characteristics and activity levels of manual wheelchair users*. J Rehabil Res Dev, 2007. **44**(4): p. 561-72.
12. ISO, I.S.O., *Mechanical Vibration and Shock-- Evaluation of human exposure to whole-body vibrations (2631-1)*. 1997, International Standards Organization.
13. Duvall, J., et al. *Development of Surface Roughness Standards for Pathways Used by Wheelchairs*. in *Transportation Research Board 92nd Annual Meeting*. 2013.
14. Duvall, J., et al., *Proposed Surface Roughness Standard for Pathways used by Wheelchairs*. Transportation Research Board 93rd Annual Meeting, 2014(14-4494).
15. Sayers, M.W. and S.M. Karamihas, *The little book of profiling*. Ann Arbor: Transportation Research Institute, University of Michigan.  
[http://www.umtri.umich.edu/erd/roughness/lit\\_book.pdf](http://www.umtri.umich.edu/erd/roughness/lit_book.pdf), 1998.
16. Washington, U.o. *Pavement Evaluation*. 2005 [cited 2011 January 30]; Available from: <http://training.ce.washington.edu/PGI>.
17. Latif, A.B.A., *Relationship bewteen international roughness index (IRI) and present serviceability index (PSI)*. 2009, Universiti Teknologi Malaysia.
18. International, A., *Standard Practice for Computing International Roughness Index of Roads from Longitudinal Profile Measurements*. 2008.
19. Loewenherz, F. *Asset Management for ADA Compliance Using Advanced Technologies*. Available from: <http://www.ite.org/Membersonly/annualmeeting/2010/AB10H4001.pdf>.