

User's Manual

Multi-Purpose Tweezer-Meter

LCR-Reader©-MP

Release 1.5



Firmware Version 1.15

Table of Contents

1	Device Use	5
1.1	Main Features	5
2	What is included in the package	5
3	Symbols and Abbreviations.....	5
4	Principle of Operation.....	6
4.1	Formulas to Determine the Parameters:.....	7
5	Safety Measures and General Instructions	7
6	Device Controls	8
6.1	Turning on the device	8
6.2	Turning off the device.....	8
6.3	Extended Voltage Range Switch	8
6.4	Controlling device using its orientation.....	8
6.5	Charging the Battery.....	9
6.6	Main and System Menu.....	9
7	Modes of Operation.....	10
7.1	R-L-C-D Mode.....	10
7.1.1	Measurements	10
7.1.2	Quick Controls.....	11
7.1.3	Open/Short Calibration	12
7.2	R-L-C-D mode menu.....	12
7.2.1	Primary Parameter	13
7.2.2	Secondary Parameter.....	13
7.2.3	Test Frequency	13
7.2.4	Test Signal Level	13
7.2.5	Period	13

7.2.6	SER/PAR Mode	13
7.2.7	Sound	13
7.2.8	C-Voltage	14
7.2.9	Sample Hold	14
7.2.10	Large Cap	14
7.2.11	Large Cap (1 uF to 40 mF) Settings	14
7.2.12	Super Large Cap > 40 mF Measurement	15
7.3	RDC+LED mode	15
7.3.1	R test at 1.2 V and R test at 100mV	16
7.4	The Voltage mode	16
7.4.1	Controls	16
7.5	Transient voltage waveforms (oscilloscope mode)	17
7.6	Oscilloscope mode settings	17
7.6.1	Controls	17
7.7	Frequency Meter mode	17
7.7.1	Changing the mode	17
7.7.2	Frequency, Period control	18
7.8	Signal Generator Mode	18
7.8.1	Controls	19
8	Device Troubleshooting	19
8.1	If the device does not turn on	19
8.2	If there are no initial zero readings on the screen	19
8.3	Technical Support	19
9	Maintenance	19
9.1	Care of the surface	19
9.2	Repairs	20
10	Storage Conditions	20
11	Transportation	20

12 Warranty.....20

1 Device Use

1.1 Main Features

- Automatic component recognition L-C-R-Diode
- Basic Accuracy of 0.1%
- DC measurement of Resistance and Capacitance up to 1 F
- Pass/No Pass Electrolyte Cap indication with Built-in Rejection table
- Automatic/manual frequency setting 100Hz, 10 Hz, 1kHz, 10 kHz, 100 kHz
- Automatic adjustment of test signal to 0.1 Vrms for in-circuit measurements
- Designated ESR measurements
- Easy Open/Short calibration for better accuracy
- Automatic detection of diode polarity and short circuits
- DC voltage measurements with automatic polarity detection
- Frequency meter
- Oscilloscope graphics for alternating voltage measurements
- Jog-dial control wheel
- Multiple Parameter Display: primary/secondary, etc.
- Screen orientation Automatic/Manually
- Sound indication
- Battery discharge warning, full charge indication
- Automatic power off when not in use
- Backlit LCD

2 What is included in the package

- LCR-Reader MP
- Case
- Offset Calibration Board
- Spare Ergonomic Bent Test Leads*
- Spare Battery*
- Kelvin Probe Connector*

3 Symbols and Abbreviations

DUT – Device Under Test

ESR - Equivalent Series Resistance

Low ESR - Ultralow Equivalent Series Resistance

Rs - Series Resistance

Ls - Inductance *in series connection*

Cs - Capacitance *in Series Connection*

Xs - *Reactance* in Series connection

Rp - Resistance in Parallel connection

L_p - Inductance in Parallel Connection
 C_p - Capacitance in Parallel Connection
 X_p - Reactance in Parallel Connection
 Q - Quality Factor
 D - Loss Tangent
 RMS - RMS value
 $TRMS$ – True RMS Value
 LF - Low Frequency
 Z - Impedance
 $|Z|$ - Impedance Module
 DDS - Direct Digital Frequency Synthesis
 DC - DC Voltage
 AC - Alternating Voltage

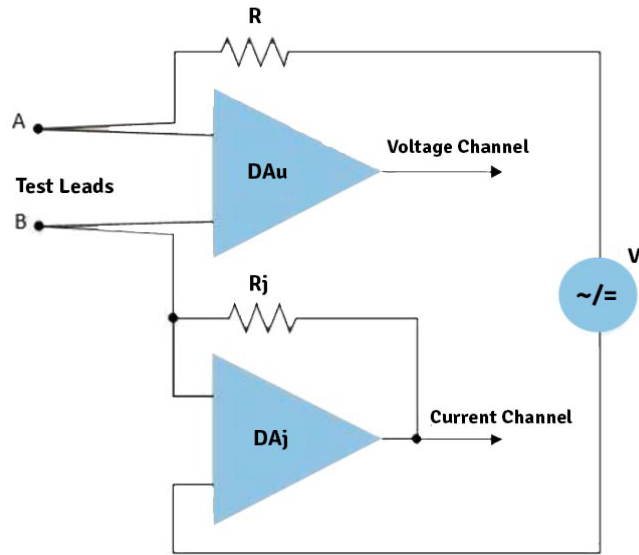

4 Principle of Operation

Fig. 1 shows the LCR meter block-diagram. Voltage from the voltage source through a limiting 1 kOhm resistor is applied to the DUT connected at points A and B. The amplitude and frequency of the Test Signal V are adjustable. It is also possible to apply either positive or negative DC voltage to the DUT. A voltage drop on the DUT is measured by DA_u . The voltage drop on resistor R_j measured by DA_j is proportional to the current flowing through the measured component. After digitizing the ADC signals the impedance is calculated according to the formula DUT impedance $Z = R_j \cdot V_{au} / V_{aj}$.

Values of Impedance obtained during calibration with Open and Short probes are stored in the non-volatile memory of the device and are taken into account in the calculation of the impedance of the measured component thus eliminating the offsets due to the device internal parasitics.

The measured component can be represented in one of the following equivalent circuits:

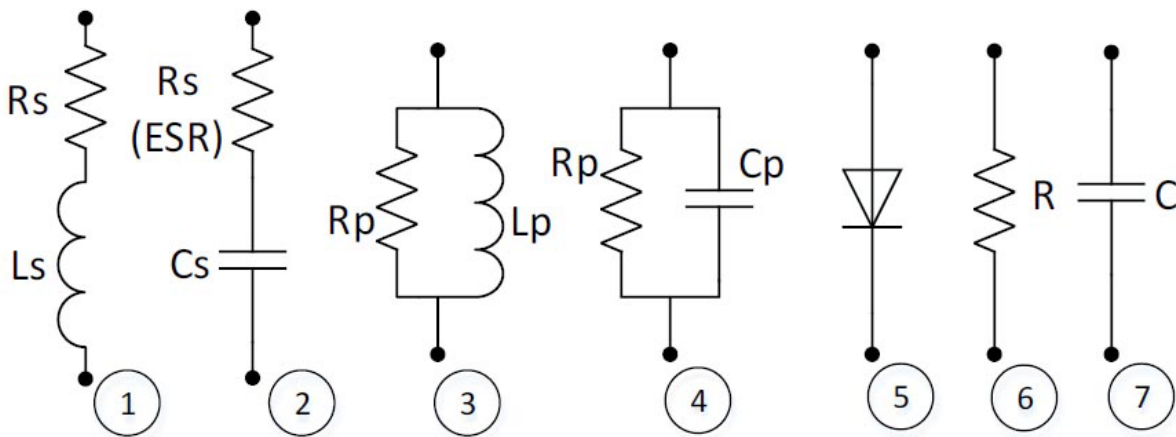

[1] and [2] : series circuits

[3] and [4] : parallel circuits

Impedance in series circuits $Z = R_s + iX_s$ and in parallel circuits $Z = 1/(1/R_p + 1/iX_p)$ where X_s (X_p) <0 if the reactance is capacitive and at X_s (X_p) >0 the reactance is Inductive.

4.1 Formulas to Determine the Parameters:

Electrical capacitance $C = 1/(2\pi f|X_s|)$ where f is the test frequency.

Inductance $L = X_s/(2\pi f)$. $Q = |X_s|/R_s$. $D = 1/Q$. $|Z| = \sqrt{R_s^2 + X_s^2}$

The device automatically selects the optimum frequency and the equivalent circuit for measurements. Users can also manually select measurement mode and frequency of the test signal can be selected from 100 Hz to 100 kHz. Test voltage can be set to 0.65 Vrms and 0.1 Vrms.

By passing direct current through the measured component, the voltage and current can be measured. Using Ohm's law, the DC current Resistance (R) can be calculated [6].

By applying the DC voltage in forward and reverse direction, the diodes [5] are detected and the polarity of p-n junction is determined.

Charging and discharging the capacitor [7] by changing the voltage on the measured component for a fixed time interval to determine capacitance for capacitors above 40 mF.

The principle of the frequency counter is based on the counting pulses of the reference generator between the two ramps of the input signal for a certain period of time (by default about 1 second). At the same time, the quantity of periods of the input signal is counted too. Then the frequency f is calculated by the formula $f = M/N * f_r$, where f is the number of periods of the input signal, M is the number of periods of the input signal, N is the number of pulses from the reference generator and f_r is the frequency of the reference generator

The principle of measuring the voltage is based on comparing the input signal with the reference voltage.

5 Safety Measures and General Instructions



For safe and reliable operation of the device, follow these rules:

1. Exercise additional caution when measuring the capacitance, inductance, resistance and diodes in a circuit with voltage applied
2. Never apply more than 20V DC or 14 Vrms to the probes with the device switch in position 2.
3. Never apply more than 1.5 V DC or 1.0 Vrms to the probes with the device switch in position 1.
4. Never measure charged Capacitors
5. Do not make measurements while the device is charging

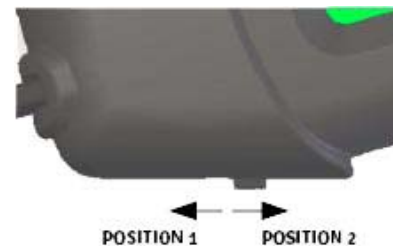

6. Charge the battery using a USB port of a computer or a DC charger 5 V +/- 5%. Do not use damaged cables or chargers. Charging in the presence of moisture may cause fire, electrical shock, injury or damage to the device or other property.
7. Do not stretch the handles for more than 20mm between the test leads.
8. This device is designed for indoor use.
9. To prevent injury from sharp ends of the test leads, transport the device in the case.
10. Do not touch non-insulated test lead surfaces during measurements. Keep fingers on the insulated surfaces of the handles.
11. Replacement of the battery must be carried out by a specialist. Batteries must be recycled or disposed of separately from regular household waste. Do not burn the battery.

6 Device Controls

6.1 Turning on the device

Press the jog-wheel down and wait until the device beeps.

6.2 Turning off the device

1. Press the jog-wheel and hold it until the device shows "Shutdown".
2. Hold with screen face-down until 3 beeps (may be enabled via menu).
3. The device turns off if it has been inactive for 120 seconds (default). The automatic time-off setting can be changed in the menu: System /Power/Time Off

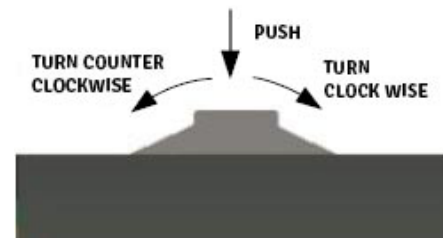

6.3 Extended Voltage Range Switch

The switch is located at the left bottom of the housing. This switch extends the range of the voltage measurements. In the Voltage and Frequency modes, the side switch in Position 2 increases the input impedance of the device from 1 kΩ to 10 MΩ and extends the range of input voltages.

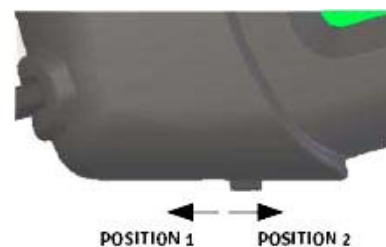

For RLCD and RD measurements, the switch should be set to Position 1.

6.4 Controlling device using its orientation

1. If you rotate and hold the device perpendicular to the floor the screen will flip orientation to the hand being used. *
2. Turn the probes up to turn on/off the indicator light
3. If you place the device on a flat surface with the screen facing up, after a few seconds the device will go into Economy mode. The display shows the battery voltage and the firmware number. *
4. If you place the device on a flat surface with the screen

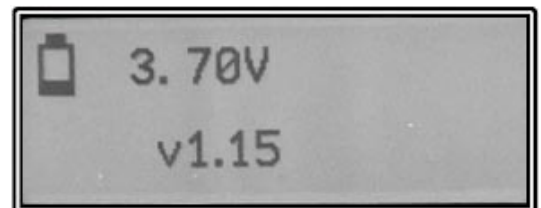

face-down, after 3 beeps the device will automatically turn off. *

*Function can be enabled/disabled through the device menu: System/Power

6.5 Charging the Battery

The device is powered by a Li-Po battery with 3.7 V rated voltage. The battery icon on the display shows the remaining charge of the battery. This icon will blink when the device's power is below 3.6 V and will automatically turn off at 3.5 V. Information about the battery voltage can be displayed in the menu: *System/Power/Battery Voltage*

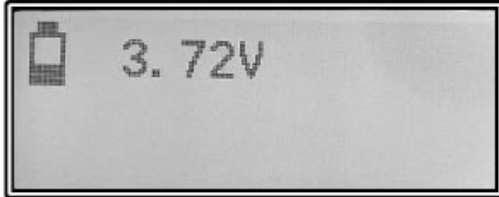

Charge the battery by connecting it via a micro-USB cable to a USB DC voltage source of 5V +/- 5%. The device's indicator light will show when the device is charging and will turn off when the charging is complete.

6.6 Main and System Menu

The device will enter the main menu when the jog-wheel is pressed. The main menu is multi-levelled. Select the appropriate menu item by moving the jog-wheel in a clockwise or counter clockwise direction and pressing down to select.

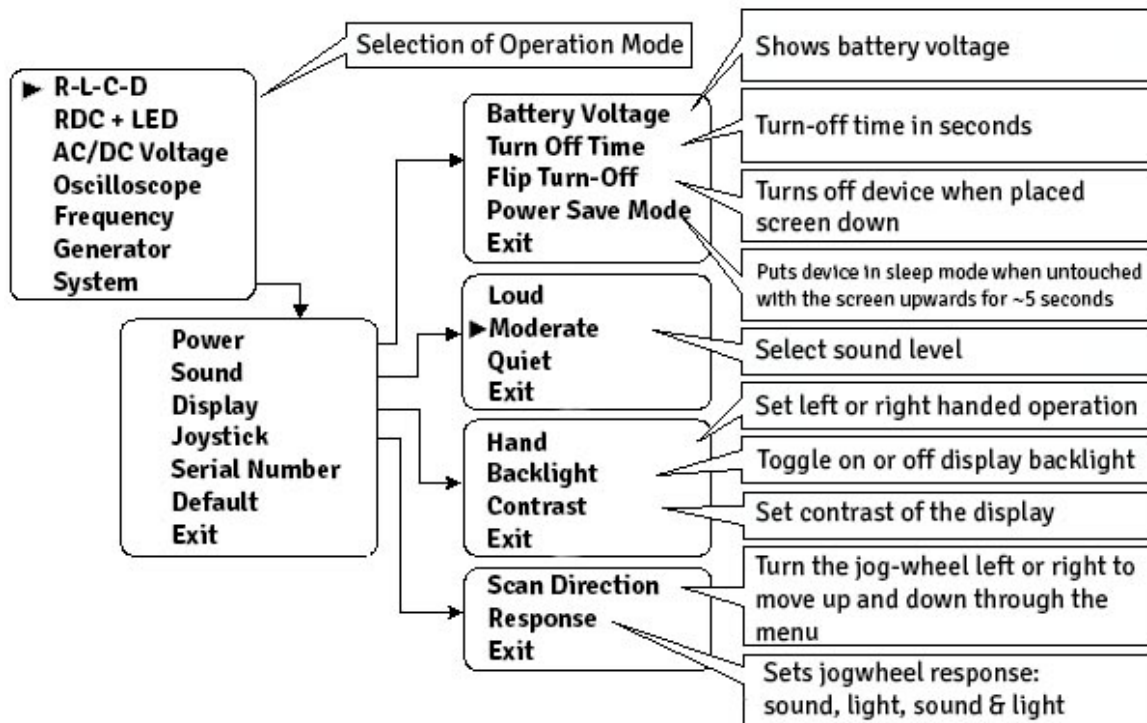

To select the menu item, highlight the corresponding menu item and press the jog-wheel.

To set the default operating mode (R-L-C-D, RDC+LED, Voltage, etc.), press and hold the jog-wheel for two beeps. This mode is then stored in the device's memory and will be activated when the device is powered on.

7 Modes of Operation

7.1 R-L-C-D Mode

This menu item is for measurement of Resistors, Capacitors, Inductances and Diodes. To select the mode, select R-L-C-D in the main menu. A typical screen looks as follows:

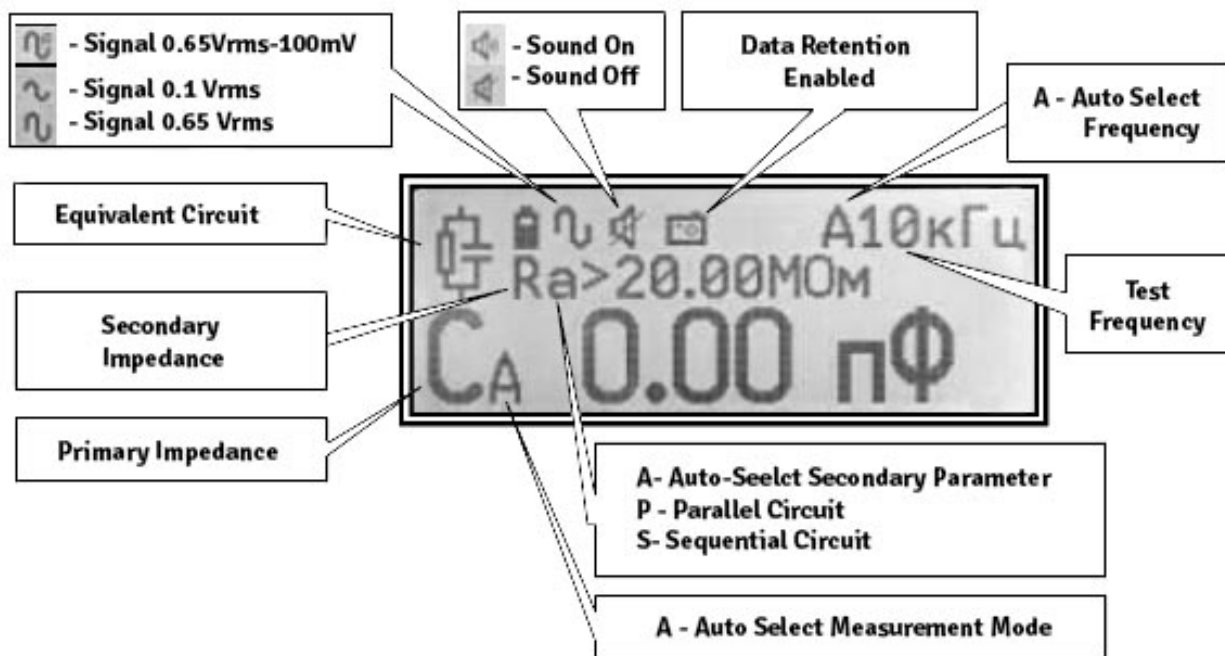

7.1.1 Measurements

When the measured component is connected to the test leads, the screen displays information depending on the component and the selected settings in the R-L-C-D mode menu.

Capacitance

Inductance



Resistance

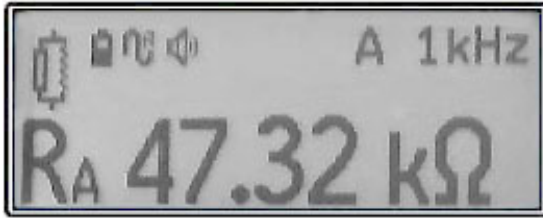

Diode



In automatic mode measurement of capacitance larger than 1 μF is made at 120 Hz, while ESR is measured at 100 kHz. In this case the frequency of the test signal is not shown on the screen. For ESR based rejection of electrolytic capacitors two tables are used, one for standard aluminum electrolytic capacitors and the other for **Low ESR** capacitors.

In this case two additional figures are displayed. The first number is the quality of the capacitor. For standard aluminum capacitors, a positive number indicate rejection, and for **Low ESR** values above -10. The 2nd number is the selected operating voltage of the capacitor. It can be specified in the menu item **Large Cap/C-voltage**.

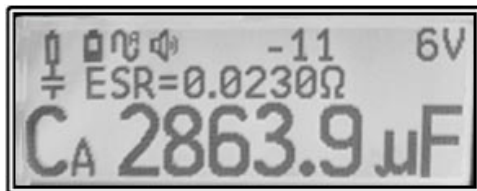

Discharge Capacitors before testing!

7.1.2 Quick Controls

- Turn the jog-wheel clockwise*until 1 beep to change the test parameters (more info below)
- Turn the jog-wheel counter clockwise until 1 beep to change the test frequency. The frequency changes cyclically Auto-100Hz-120Hz-1kHz-10kHz-100kHz. If the frequency is selected from the menu in the range 20-75kHz, the frequency changes cyclically 20kHz-30kHz-40kHz-50kHz-60kHz-75kHz-100kHz
- Turn the jog-wheel clockwise until 2 beeps to eliminate the offset. If the probes are shorted, parasitic resistance is obtained. If the probes are open, parasitic capacitance is obtained. Please use LCR-Reader Calibration Board to set a proper distance between the test leads (according to the component size) because the parasitic capacitance depends on the distance.
- Turn the jog-wheel 1 beep counter clockwise to toggle the signal level between Auto and fixed 0.65Vrms
- If the probes are not connected to anything, press and hold up to 2 peaks to toggle the test frequency between Auto and 100 kHz. If a part is connected to the probes, then relative measurements are made showing the difference from the first measured component. Additional symbol in the top-middle of the screen is displayed.

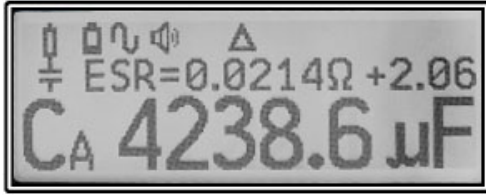

*When connected to the Capacitance is greater than 1 μF range for the operating voltage

7.1.3 Open/Short Calibration

Before the first use, the device must be calibrated with Open and Short probes for each test frequency. When the device is set to Auto-frequency the device automatically calibrates at 100Hz, 1 kHz, 10kHz, and 100kHz. To eliminate the offset, turn the jog-wheel clockwise, hold until 2 beeps and release. When measuring small capacitances less than 100 pF, use LCR-Reader Offset Calibration Board included in the package. Insert the test leads at the distance of the size of the component and calibrate with open probes. Only then measure the capacitor.

Before measuring small inductances (less than 1μH) and resistances (less than 10 Ohm) wipe off the tips of any dirt and oxides and calibrate with short probes.

7.2 R-L-C-D mode menu

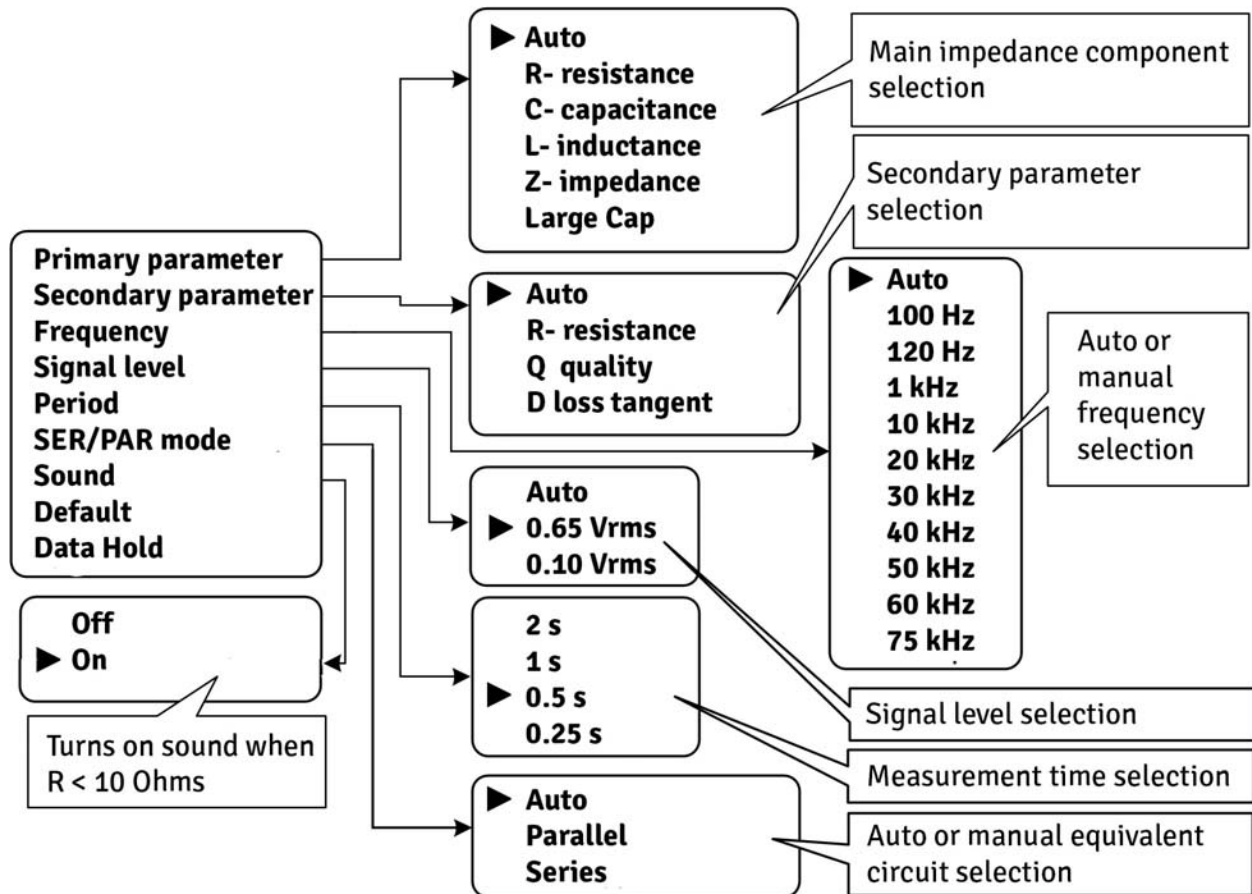

7.2.1 Primary Parameter

In Auto mode, the type of measured component is determined automatically: R: Resistor, L: Inductance, C: Capacitor, D: Diode. Measurement mode can also be set manually to R, L, C, Z as the impedance.

7.2.2 Secondary Parameter

In Auto mode for inductors quality Q factor is displayed for $Q > 1$ and series Resistance R_s for $Q < 1$, and for capacitors, loss tangent for $C < 1 \mu\text{F}$ and ESR for $C > 1 \mu\text{F}$. Automatic secondary parameter selection does not work if the Test Signal is set to Automatic, R is used as the secondary parameter in this case.

7.2.3 Test Frequency

This menu item allows to select frequency of the test signal. In Auto mode, the device automatically selects a frequency of 100Hz, 120 Hz, 1 kHz or 10 kHz, depending on the rating and type of the component. Users can also manually select the test frequency. A higher frequency is used for measuring small values of capacitances and inductances. Resistor measuring are always made at 1 kHz unless **RDC+LED** Mode is selected. If 100 kHz frequency is required, press the jog-wheel and hold for 2 beeps.

7.2.4 Test Signal Level

For more stable readings, select 0.65Vrms or Auto signal level. Auto is best for measuring loose components and in-circuit measurements of R, C, L. When measuring on boards, if at high test signal level opens p-n junctions of semiconductors components causing an error in the measurements, then the signal level is automatically reduced to 0.1 Vrms and the value is re-measured. In this case, the screen shows the diode symbol and the direction of the p-n junction.



7.2.5 Period

Increased measurement time results in more stable readings, reduced time results in faster updates on the screen.

7.2.6 SER/PAR Mode

This is used to select the equivalent circuit depending on the characteristics of the element.

7.2.7 Sound

The device will beep when the resistance is less than 10 Ohm or a short circuit is found.

7.2.8 C-Voltage

C-Voltage has to be selected in the menu when evaluating electrolytic capacitors for rejection by ESR. The voltage is written on the capacitor's housing.

7.2.9 Sample Hold

When selected, the device will hold measurement data on the screen. A beep will sound when the measurement is made and the values are held on the screen after the component has been disconnected from the device. The device will only reset when a new component is measured or the test probes are shorted.

In order to set the default measurement mode when the device is turned on, select the mode, press the jog-wheel and hold until 2 beeps. This measurement setting will be stored in the device's non-volatile memory for all other measurements until selecting other parameters or Default in the menu.

7.2.10 Large Cap

In this mode, capacitance and ESR of capacitors from 1 μF to 40 mF are measured. The capacitance is measured at a frequency of 50Hz, and the capacitor's ESR is measured at the frequency of 100 kHz.

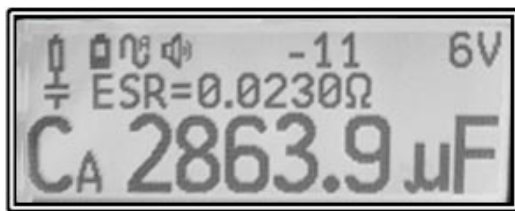

Discharge Capacitors before testing!

If open p-n junctions of semiconductor components cause an error in the measurements, then the screen shows the diode symbol and the direction of the p-n junction is shown instead of the primary parameter type.

If the resistance of the component is less than 10 ohms, there will be short beeps. Before the first application in this sub-mode it is necessary to calibrate the device with both open and shorted probes.

For the rejection of electrolytes based on ESR, two tables are stored in the memory of the device, one for standard aluminum capacitors and the other for **Low ESR** capacitors. Two additional numbers are displayed on the screen in this case: the first number is the quality of the capacitor. For standard aluminum capacitors, positive values indicate rejection, and for **Low ESR** rejected values are above -10. The second number is selected operating voltage of the capacitor in menu under C voltage: 6.3, 10, 16, 2, 3, 50-63, 100, and 160+ Volts. This menu opens by clockwise turn of the jog-wheel.

7.2.11 Large Cap (1 μF to 40 mF) Settings

- Clockwise until 1 beep to open the mode menu.
- Clockwise until 2 beeps to make calibration eliminating the offset. Only short calibration is required.
- Counter clockwise until 2 beeps to toggle the test signal level between 0.65 Vrms and 0.1 Vrms.

7.2.12 Super Large Cap > 40 mF Measurement

- When in the Large Cap mode, counter clockwise until 1 beep to switch to DC capacitance measurement mode for Capacitors larger than 40 mF up to 680 mF. To speed up the settling of the readings, short the capacitor leads for 2-3 seconds before the measurements. Counter clockwise until 1 beep again to return to the normal Large Cap mode.

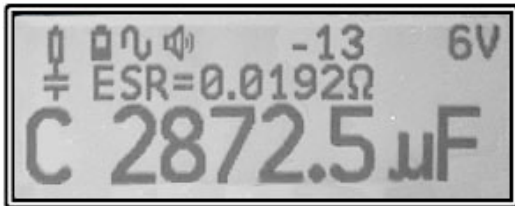

Discharge Capacitors before testing!

7.3 RDC+LED mode

This mode is designed to measure DC resistance, parameters of Diodes/LEDs, and leakage currents. Besides, it allows to measure a shunt resistor on a board that can be used for evaluating the current via that shunt in a live circuit.

- Clockwise until 1 beep to open the mode menu. Select sub-modes: Auto, Diode, R test at 1.2 V, R test at 100 mV.
- Clockwise until 2 beeps to calibrate with open and short probes to eliminate the offset.

In the Auto mode resistances and diodes are automatically detected. The bottom line displays the resistance of the connected element, at the top the current I_r flowing through it. For diodes, the polarity of the diode, the voltage drop in the open state and the reverse current I_r are displayed.

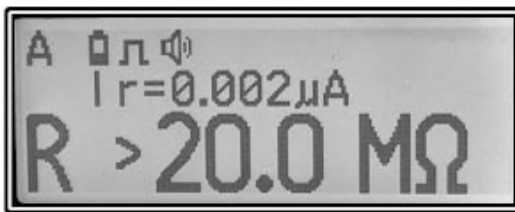

Diode mode is used for diode parameter extraction using DC bias. It is recommended for in-circuit characterization of p-n junctions. The screen displays the voltage drop in the open state when the forward bias is applied. If the reverse bias is applied, OL is displayed instead. Turn the jog-wheel anti-clockwise until 1 beep to change the polarity of the probes.

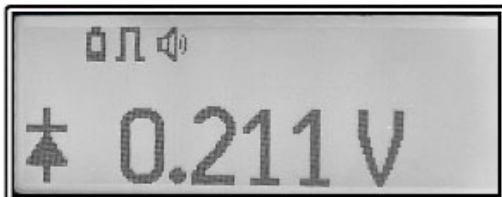

7.3.1 R test at 1.2 V and R test at 100mV

These modes are used to measure DC resistance, recommended for in-circuit detection of resistors. It also allows to measure a shunt resistor on the board that could be used for current measurements.

- Press until 1 beep to save the resistance value (shunt) in the device memory for the current measurements. Read below about the current measurement in the **Voltage mode** section.



7.4 The Voltage mode

This mode is to measure DC and AC voltage. The device automatically detects the polarity of the DC voltage. The upper line of the display shows the values of the RMS voltage. The second line shows the peak-to-peak voltage range.

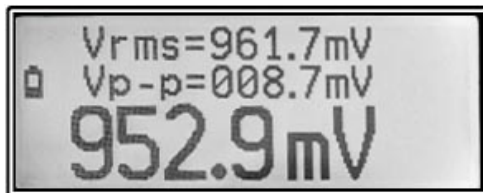

7.4.1 Controls

- Clockwise until 1 beep turns on (off) the current measurement mode.

In this mode, the voltage value measured on the external resistors (shunts) is converted into a current and displayed on the screen. In the upper line of the screen the resistance is displayed, taking into account the input resistance of the device, and the lower value of the current. To enter the resistance of the shunt into the instrument memory, go to the RDC+LED mode. With the circuit de-energized, connect the shunt and press the switch, hold until 2 beeps.



- Anti-clockwise until 1 beep to turn on and off the capture mode of the maximum and minimum voltage values.

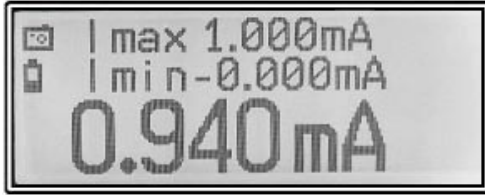

- Clockwise until 2 beeps to calibrate with short probes to eliminate the offset. The switch must be in position 1 in order to do the calibration (see Section 6.3 Extended Voltage Range Switch).

7.5 Transient voltage waveforms (oscilloscope mode)

In this mode, you can view the voltage waveform. On the right side of the screen, the horizontal scale (T / pixel), vertical scale (V / div), signal frequency and signal sweep are displayed.

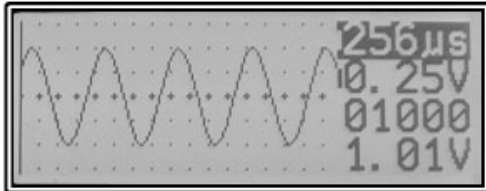

7.6 Oscilloscope mode settings

Usually automatic parameter settings are acceptable. The two parameters can be adjusted manually are, the time scale (T/pix) and the voltage scale (V/div).

7.6.1 Controls

- Clockwise until 1 beep to increase parameter.
- Counter clockwise until 1 beep to decrease parameter.
- Counter clockwise until 2 beeps to select the parameter to change: T/pix or V/div.
- Clockwise until 2 beeps to automatic selection of T/pix (V/div).
- Press and hold up to 2 peaks to enter the waiting oscilloscope mode. In the window, set the parameters T/pix and V/div as indicated above. Press and hold up to 2 peaks again to activate the mode. The word "Wait" is displayed on the screen. When the signal is applied to the probes, 675 sample points are recorded. Turn the joystick clockwise or counter clockwise to view the signal on the screen.

7.7 Frequency Meter mode

In this mode, it is possible to measure frequency, pulse duration, duty cycle, period and count the number of pulses.

7.7.1 Changing the mode

Clockwise until 1 beep to open menu to select the desired mode. When the mode is selected, hold until to 2 beeps, to make the mode default.

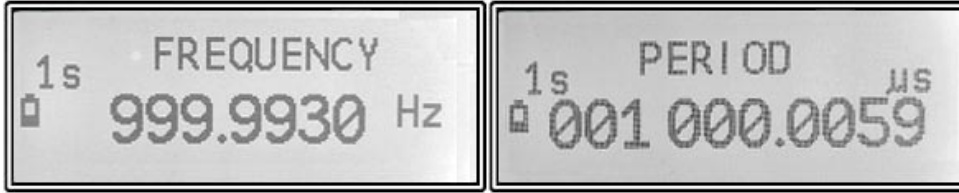

7.7.2 Frequency, Period control

- Counter clockwise until 1 beep to change the measurement time cyclically 0.25s-0.5s-1s-2s.

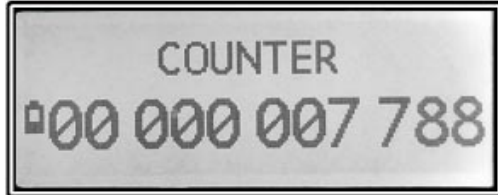

- Counter clockwise until 1 beep to reset the counter

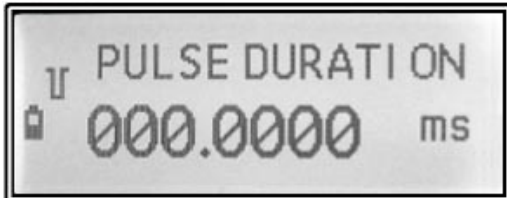

- Counter clockwise until 1 beep to measure of a positive or negative pulse.

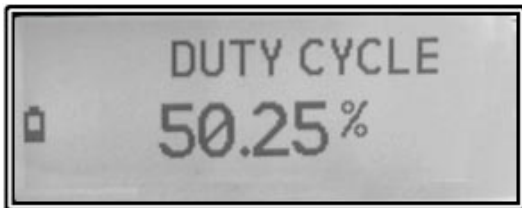

7.8 Signal Generator Mode

Sine, triangle, and meander signals are generated. The signal is applied to the device probes. It is possible to adjust the span (peak-to-peak) of a signal from 0.1 to 2.8 V, a constant bias of ± 0.6 V *, and a duty cycle of 5 ... 95% in 5% increments. Parameters are stored when exiting the mode. On the right of the screen from top to bottom: sweep, offset, duty cycle and the waveform icon. The frequency in Hz is displayed in the center of the screen.



The self-shutdown time is 4 times longer than the default in other regimes. An external decoupling capacitor is required to supply a signal to a circuit under voltage. It should be connected to a probe located closer to the side switch. The other probe is a common one. In this mode, the device does not turn-off by "flipping" and the function of automatic change of display orientation (left/right hand) is disabled. It is recommended to use LCR-Reader Kelvin Probe Connector to simplify the device operation in this regime.

7.8.1 Controls

- Clockwise 1 beep to select the item to change.
- Anti-clockwise 1 beep to increase the selected parameter.
- Clockwise 2 beeps to go to the initial position.
- Down 2 beeps to change the waveform type.
- The sum of the displacement and 1/2 of the span must be less than or equal to 1.4 V.

8 Device Troubleshooting

8.1 If the device does not turn on

- a. Push the joystick and hold it until one beep, then release it.
- b. Charge the battery.
- c. Contact the manufacturer for repair.

8.2 If there are no initial zero readings on the screen

- a. From the system menu, select Default.
- b. Clean the contacts and calibrate with both closed and open probes.
- c. Review this manual to find possible errors in operating the device.

8.3 Technical Support

Customers can contact customer support by phone +1-519-888-9906 or by e-mail info@lcr-reader.com.

When contacting technical support, please provide the following information:

- Model number
- Serial number of the device
- Software version number

9 Maintenance

9.1 Care of the surface

- a. Do not expose housing to water, it is not waterproof.

- b. Do not expose the display for a long period of time to direct sunlight.
- c. Use a soft cloth dampened with water to clean the outside surface and cleaning the LCD display device.
- d. Do not use liquid solvents or detergents.

9.2 Repairs

If there is an unexpected measurement result, check the quality of the contact between the tips of the device probes and the element being examined. Make sure you make the measurements correctly. Carry out the instrument diagnostics. Do not dismantle the case or replace individual elements or circuits. For repair, please contact the manufacturer.

10 Storage Conditions

- Temperature and humidity during storage: -10 ° C to 50 ° C with relative humidity <80%.
- There should be no dust, acid and alkali vapours in the storage room.
- Recharge the built-in battery once every 6 months.

11 Transportation

All modes of transportation at ambient temperatures from -40 ° C to + 50 ° C

The device must be protected against precipitation and dust.

12 Warranty

The manufacturer (dealer) guarantees the conformity of the device parameters to the data, described in the Technical Specifications subject to the consumer rules of operation, maintenance and storage, specified in this manual. Warranty period - 12 months. The warranty period for the battery is 6 months. This warranty does not cover normal wear and tear on the surface of the case, the display, the probes. This warranty does not apply to physical damage to the housing, display, probes, switches, electrical damage to the product due to high voltage.