



PROPULSE™
A SCHIEFFER CO.

POWER MOVING FORWARD™



PROPULSE HYDRAULIC MANUAL

TABLE OF CONTENTS

If you have questions about the products contained in this catalog, or their applications, please contact:

ProPulse, A Schieffer Co.
Phone: 877.384.4673
Fax: 800.303.4673
www.PowerMovingForward.com

Extra care is taken in the preparation of this literature, but ProPulse is not responsible for any inadvertent typographical errors or omissions. Information is subject to change without notice. The information in this catalog is only accurate as of the date publication. For more information, please visit www.PowerMovingForward.com.

ProPulse Publication No. 20155002
Revised: May, 2015

HOSE INSTALLATION AND BEST PRACTICES	2
FLUID COMPATIBILITY CHART	4
CONVERSION TABLES	8
HOW TO MEASURE ASSEMBLIES	9
PRESSURE CONVERSIONS	10
WORKING PRESSURE HOSE SELECTION	11
HOSE INDEX	12
FITTING INDEX	13
WARNING	81
WARRANTY	82

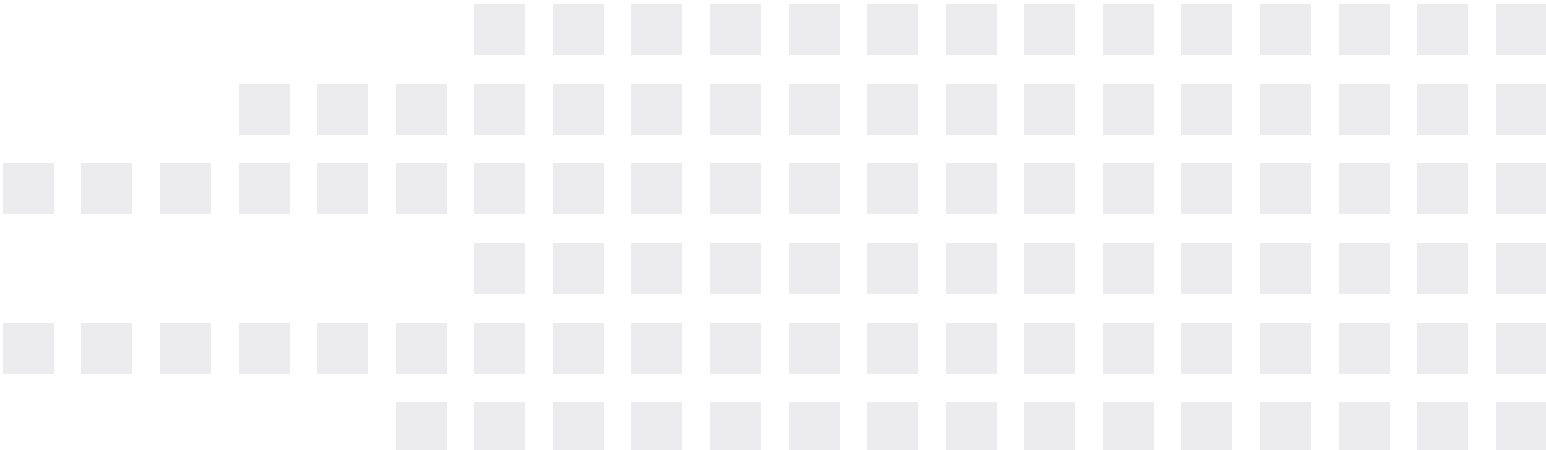

HOSE INSTALLATION AND BEST PRACTICES

There are several items that play a role into the selection of the correct hose for your application. Hose selection should not be taken lightly. For instance, there are several different safety factors that are applied to different industries. An SAE designated hydraulic hose has a 4-1 safety factor where other industries may have other allowable safety factors that are less than 4 such as in some high pressure cleaning applications (3-1), jack hose applications (2-1), as well as in the sewer jetting industry (2.5-1). Be sure to pick the hose that meets the application requirements.

Other factors will also play a role in the life of the hose in an application. These include but are not limited to various application factors such as hose routing and various environments. Routings and environmental conditions can cause hoses to fail prematurely from the outside in. The ProPulse team can assist customers with these applications by providing the proper solution to meet your need. This can include ozone and uv resistant thermoplastic hose, Arm series hose with our Arm-A-Flex™ extreme duty cover, or even a hose wrap or nylon covering to help with stand the rigors of usage. In addition, the Propulse team can help with routing solutions and advice with the proper use of adapters and clamps to keep your hoses "happy" for years of trouble free service.

Following is a list of basic drawings that help with every day hose routing issues our customers face. This guide can help aid in the proper routing and installation of hose assemblies in various applications.

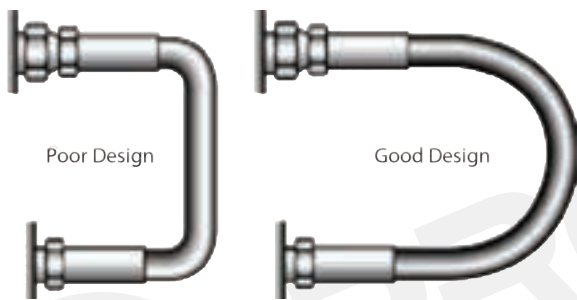

FIGURE 1

In the right picture of figure 1, the hose is too short not allowing for the hose to have the proper bend radius. This causes strain on the crimp joint. The top picture shows the correct hose length providing correct bend radius.

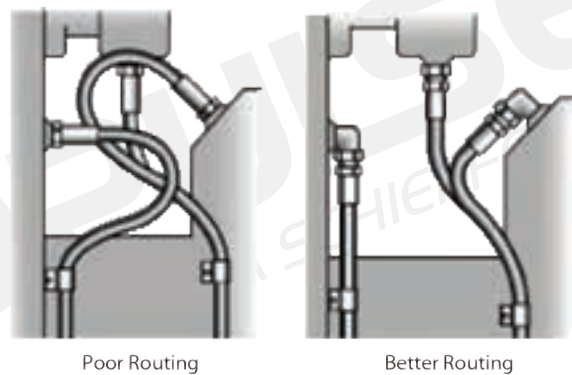

FIGURE 2

To the left shows a cluttered hose routing that could induce unnecessary hose wear and hose life. Better choice of end fittings and use of adapters helps clean up the routing facilitating longer hose life and is easier to maintain.

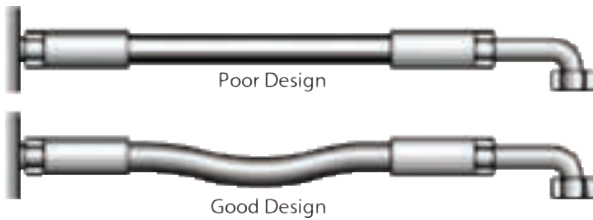

FIGURE 3

Hose length should be looked at closely to provide for the flexing of hose when there is contraction and expansion during use.

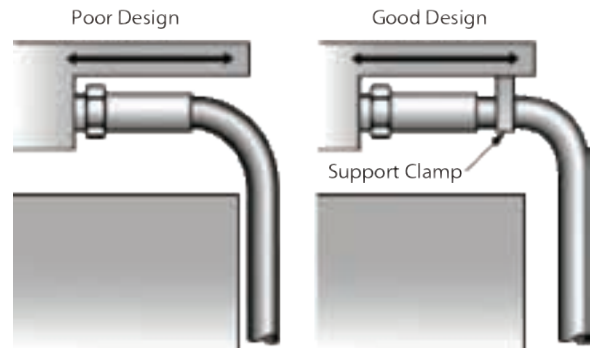

FIGURE 6

Support clamps are also a good tool to use when trying to limit hose wear due to abrasion. Clamps can be used to isolate hose and hold them away from abrasive surfaces or environments.

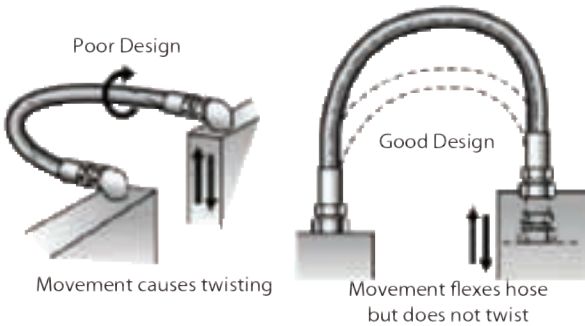

FIGURE 4

Be aware of hose routings that have torsion and twisting involved. Hoses should be routed to limit this torsion as it can have a negative effect on the crimp integrity and can reduce hose length. A good tip to help identify this issue is to look at the hose layline if there is torsion in the hose (even when installing the hose layline will appear twisted along the length of the hose). This condition will indicate torsion with the hose and could shorten the life.

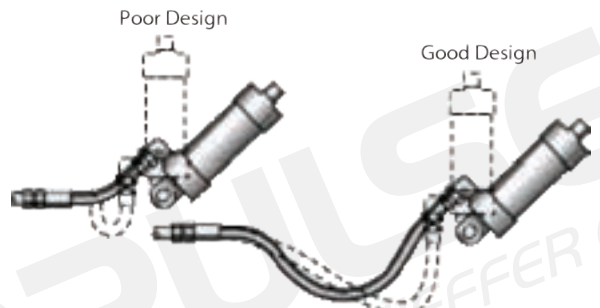

Figure 7

When routing hose, care must be given to note all areas that have movement and how the hose will move in the system. No part of the system movement should cause the hose bend radius to be exceeded or cause undue stress at the crimp joint.

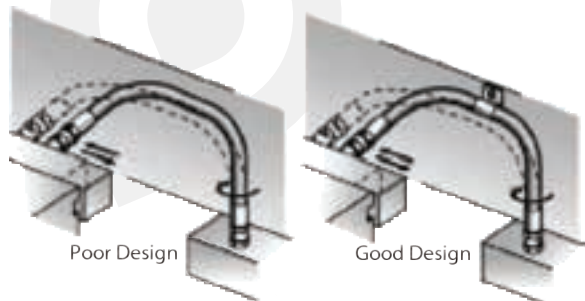

FIGURE 5

The proper use of clamps can help relax when there is movement in more than one plane. Caution must be taken that the correct clamp is used as to not damage the cover of the hose and to provide enough length of hose on either side of the clamp to provide enough room for movement.

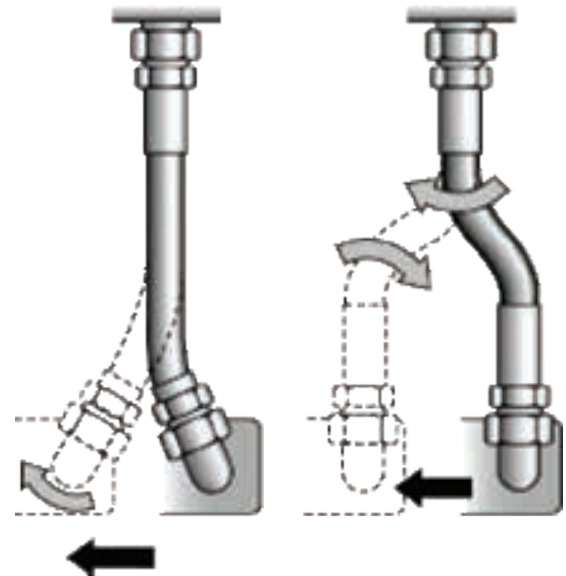

FIGURE 8

Choosing the correct fittings on the hose can also improve hose life. In this case swivel ends are used to limit torsion in the hose. Swivel ends can also aid in maintenance and replacement.

PROPULSE HYDRAULIC MANUAL

FLUID COMPATIBILITY CHART

COMPATIBILITY KEY

E = Excellent
 G = Good
 F = Fair
 X = Unsatisfactory
 * = No Data

CHEMICALS	SYNTHETIC RUBBER HOSE	THEMOPLASTIC HOSE
A ACETALDEHYDE	X	F
ACETIC ACID , 10 %	X	E
ACETIC ACID , 50 %	X	F
Acetic acid glacial	F	E
ACETIC ANHYDRIDE	X	G
ACETONE	X	F
ACETYLENE	E	E
ACRYLIC ACID	*	*
ADIPIIC ACID	G	*
Air (100C)	G	G
AIR, +300 F	X	X
ALUM	E	*
ALUMINUM CHLORIDE	E	G
Aluminum Fluoride, 10% aq	E	F
ALUMINUM HYDROXIDE	G	G
Aluminum Nitrate, 10% aq	E	*
Aluminum Sulfate, 10% aq	E	G
AMINOBENZENE	X	F
AMINODIMETHYLBENZENE	X	F
Ammonia, Aqueous	F	*
Ammonium Carbonate, 10% aq	X	*
AMMONIUM CHLORIDE	E	E
AMMONIUM HYDROXIDE	X	G
Ammonium nitrate (in aqueous solution)	E	*
Ammonium phosphate (aq)	E	*
Ammonium sulphate (in aqueous solution)	E	G
Amyl acetate	X	G
Amyl Alcohol	G	E
Aniline	X	X
Aniline Dyes	X	X

⚠ WARNING: This information shall be intended only as reference to chemical compatibility with the internal fluid. No representations, guarantees or warranties of any kind are made as to its accuracy, suitability for particular applications or the results to be obtained. Other operational factors may also impact the service life of the hose. It is advisable to test the material under actual service conditions before specification. This information must not be used in conjunction with any other compatibility information from previous or future catalog editions, bulletins or publications. Incorrect use of these charts could result in death, personal injury or property damage.

COMPATIBILITYKEY

E = Excellent

G = Good

F = Fair

X = Unsatisfactory

* = No Data

PROPULSE HYDRAULIC MANUAL

FLUID COMPATIBILITY CHART

CHEMICALS	SYNTHETIC RUBBER HOSE	THERMOPLASTIC HOSE
ANIMAL FATS	E	F
ARGON	E	E
ARSENIC ACID	E	*
ASPHALT	F	G
ASTM FUEL A	E	E
ASTM FUEL B	E	E
ASTM FUEL C	G	E
ASTM OIL NO.1	E	E
ASTM OIL NO.2	E	E
ASTM OIL NO.3	E	E
ASTM OIL NO.4	G	E
AUTOMATIC TRANSMISSION FLUID	E	G
B BARIUM CHLORIDE	E	*
BARIUM HYDROXIDE	E	G
Barium Sulfide, 10% aq	E	*
BEER	E	E
BENZALDEHYDE	X	*
BENZENE	X	G
BENZINE	E	*
BENZOIC ACID	X	*
BENZYL ALCOHOL	X	E
Black Sulfate Liquor	F	*
BLAST FURNACE GAS	X	*
BLEACH	X	E
BORAX SOLUTION	F	E
BORIC ACID	E	E
BRAKE FLUID (HD-557) 12 DAYS	F	*
Brine	E	*
BROMINE, DRY	F	*
BROMOBENZENE	X	*

⚠ WARNING: This information shall be intended only as reference to chemical compatibility with the internal fluid. No representations, guarantees or warranties of any kind are made as to its accuracy, suitability for particular applications or the results to be obtained. Other operational factors may also impact the service life of the hose. It is advisable to test the material under actual service conditions before specification. This information must not be used in conjunction with any other compatibility information from previous or future catalog editions, bulletins or publications. Incorrect use of these charts could result in death, personal injury or property damage.

PROPULSE HYDRAULIC MANUAL

FLUID COMPATIBILITY CHART

COMPATIBILITY KEY

E = Excellent
 G = Good
 F = Fair
 X = Unsatisfactory
 * = No Data

CHEMICALS	SYNTHETIC RUBBER HOSE	THERMOPLASTIC HOSE
BUNKER OIL	E	*
BUTADIENE	X	G
BUTANE	E	E
BUTYL ACETATE	X	G
BUTYL ALCOHOL	E	E
BUTYL CELLOSOLVE	F	*
BUTYL STEARATE	G	*
BUTYLENE	G	G
BUTYRALDEHYDE	X	*
BUTYRIC ACID	*	*
C Calcium Acetate, 10% aq	G	*
CALCIUM BICHROMATE	*	*
Calcium Bisulfate, 10% aq	X	*
Calcium carbonate	E	G
CALCIUM CHLORIDE	E	E
CALCIUM HYDROXIDE	E	G
CALCIUM HYPOCHLORITE	E	G
Calcium Nitrate	E	*
CARBOLIC ACID (PHENOL)	X	*
CARBON DI SULPHIDE	F	*
CARBON DIOXIDE	E	E
CARBON MONOXIDE	E	E
Carbon Tetrachloride	F	G
CARBONIC ACID	F	F
CASTER OIL	G	G
CAUSTIC SODA (SEE SOD. HYD.)	F	G
Cellosolve Acetate	X	*
China Wood Oil (Tung Oil)	E	G
CHLORINATED SOLVENTS	X	*
CHLORINE SOLUTIONS	X	X

⚠ WARNING: This information shall be intended only as reference to chemical compatibility with the internal fluid. No representations, guarantees or warranties of any kind are made as to its accuracy, suitability for particular applications or the results to be obtained. Other operational factors may also impact the service life of the hose. It is advisable to test the material under actual service conditions before specification. This information must not be used in conjunction with any other compatibility information from previous or future catalog editions, bulletins or publications. Incorrect use of these charts could result in death, personal injury or property damage.

COMPATIBILITYKEY

E = Excellent

G = Good

F = Fair

X = Unsatisfactory

* = No Data

PROPULSE HYDRAULIC MANUAL

FLUID COMPATIBILITY CHART

CHEMICALS	SYNTHETIC RUBBER HOSE	THERMOPLASTIC HOSE
CHLOROACETIC ACID	X	X
CHLOROBENZENE	X	X
CHLOROFORM	X	F
CHLOROSULFONIC ACID	X	X
CHROME PLATING SOLUTIONS	X	*
CHROMIC ACID	X	*
CITRIC ACID	E	E
COAL OIL	X	*
COAL TAR	E	*
COAL TAR NAPHTHHA	*	*
COCONUT OIL	E	E
COKE OVEN GAS	X	*
COPPER CHLORIDE	F	E
COPPER CYANIDE	E	*
COPPER HYDROXIDE	*	*
COPPER SULFATE	E	E
CORN OIL	E	E
COTTONSEED OIL	F	E
Creosote (Coal Tar)	E	*
CRUDE OIL	G	X
CUMENE	X	*
CUPRIC HYDROXIDE	*	*
CUPRIC SULFATE	*	*
CYCLOHEXANE	G	E
CYCLOHEXANOL	F	E
Cyclohexanone	X	*
CYCLOPENTANE	*	E
CYCLOPENTANOL	*	E
D DDT IN KEROSENE	E	*
DETERGENT, WATER SOLUTION	E	G

⚠ WARNING: This information shall be intended only as reference to chemical compatibility with the internal fluid. No representations, guarantees or warranties of any kind are made as to its accuracy, suitability for particular applications or the results to be obtained. Other operational factors may also impact the service life of the hose. It is advisable to test the material under actual service conditions before specification. This information must not be used in conjunction with any other compatibility information from previous or future catalog editions, bulletins or publications. Incorrect use of these charts could result in death, personal injury or property damage.

PROPULSE HYDRAULIC MANUAL

FLUID COMPATIBILITY CHART

COMPATIBILITY KEY

E = Excellent
 G = Good
 F = Fair
 X = Unsatisfactory
 * = No Data

CHEMICALS	SYNTHETIC RUBBER HOSE	THERMOPLASTIC HOSE
DEVELOPING FLUID (PHOTO)	E	*
Diacetone Alcohol (Acetol)	X	*
DIAMMONIUM PHOSPHATE	*	*
DIAMYL NAPHTHALENE	*	*
DIBENZYL ETHER	X	*
DIBROMOBENZENE	*	*
DIBROMOMETHANE	*	*
DIBUTYL ETHER	X	*
DIBUTYLAMINE	X	*
DICHLOROBENZENE	X	*
DICHLORODIFLUOROMETHANE	*	*
DICHLOROETHANE	*	*
DICHLOROETHYL ETHER	*	*
DICHLOROHEXANE	*	*
DICHLOROMETHANE	*	*
DICHLOROPROPANE	*	*
DICHLOROTOLUENE	*	*
DIESEL OIL	E	E
DIETHANOL AMINE	*	*
DIETHYLENE GLYCOL	E	G
DIETHYL ETHER	X	*
DIETHYL KETONE	*	*
DIETHYL SULFATE	*	*
DIETHYLAMINE	F	*
DIETHYLPHTHALATE	*	*
DI-ISO BUTYLENE	G	*
DIMETHYL FORMAMIDE	G	*
DIMETHYL KETONE	*	*
DIMETHYL SULFATE	*	*
DIMETHYLAMINE	*	*

⚠ WARNING: This information shall be intended only as reference to chemical compatibility with the internal fluid. No representations, guarantees or warranties of any kind are made as to its accuracy, suitability for particular applications or the results to be obtained. Other operational factors may also impact the service life of the hose. It is advisable to test the material under actual service conditions before specification. This information must not be used in conjunction with any other compatibility information from previous or future catalog editions, bulletins or publications. Incorrect use of these charts could result in death, personal injury or property damage.

FLUID COMPATIBILITY CHART

COMPATIBILITYKEY

- E = Excellent
- G = Good
- F = Fair
- X = Unsatisfactory
- * = No Data

CHEMICALS	SYNTHETIC RUBBER HOSE	THERMOPLASTIC HOSE
DIMETHYLBENZENE	*	*
DISODIUM PHOSPHATE	*	*
DIVINYLBENZENE	*	*
Dowtherm A&E	X	*
DRY CLEANING FLUIDS	F	*
E ETHANOIC ACID	*	*
ETHANOL (GRAIN ALCOHOL)	F	E
ETHANOLAMINE	G	*
ETHERS	X	*
ETHYL ACETATE	X	G
ETHYL ALCOHOL	F	E
ETHYL ALDEHYDE	*	*
ETHYL BENZENE	X	*
ETHYL CELLULOSE	G	*
ETHYL CHLORIDE	X	F
ETHYL ETHER	F	*
ETHYL PHTHALATE	*	E
ETHYL SILICATE	E	*
ETHYLAMINE	*	*
ETHYLENE DIAMINE	E	*
ETHYLENE DIBROMIDE	X	*
ETHYLENE DICHLORIDE	X	*
ETHYLENE GLYCOL (50%)	E	E
F FATTY ACIDS	F	F
FERRIC CHLORIDE	E	G
FERRIC NITRATE	E	*
FERRIC SULFATE	E	*
FLUOROBORIC ACID	E	*
FORMALDEHYDE	X	F
FORMIC ACID	X	F

⚠ WARNING: This information shall be intended only as reference to chemical compatibility with the internal fluid. No representations, guarantees or warranties of any kind are made as to its accuracy, suitability for particular applications or the results to be obtained. Other operational factors may also impact the service life of the hose. It is advisable to test the material under actual service conditions before specification. This information must not be used in conjunction with any other compatibility information from previous or future catalog editions, bulletins or publications. Incorrect use of these charts could result in death, personal injury or property damage.

PROPULSE HYDRAULIC MANUAL

FLUID COMPATIBILITY CHART

COMPATIBILITY KEY

E = Excellent
 G = Good
 F = Fair
 X = Unsatisfactory
 * = No Data

CHEMICALS	SYNTHETIC RUBBER HOSE	THERMOPLASTIC HOSE
FREON 113	E	E
FREON 12	G	E
FREON 22	X	E
FREON SO 2	*	E
FUEL OIL	E	E
G Gallic Acid, Solution	G	*
GAS, COAL	*	E
GAS, HIGH OCTANE	G	E
Gasohol	G	E
GLUCOSE	G	G
GLYCERINE	E	E
GREASE	E	E
Green Sulfate Liquor	G	*
H HELIUM	E	E
Heptane	G	E
Hexaldehyde	X	G
HEXANE	F	E
HEXENE	G	E
HYDRAULIC & MOTOR OIL	E	E
HYDRAZINE	G	X
HYDROBROMIC ACID	X	X
HYDROCIANIC ACID	F	F
HYDROCLORIC ACID	X	F
HYDROFLUORIC ACID	X	X
Hydrofluorosilic Acid	G	X
HYDROGEN CHLORIDE ANHYDROUS	*	*
HYDROGEN DIOXIDE (10 %)	*	*
HYDROGEN GAS	E	E
HYDROGEN PEROXIDE 10 %	X	*
HYDROGEN PEROXIDE OVER 10 %	X	*

⚠ WARNING: This information shall be intended only as reference to chemical compatibility with the internal fluid. No representations, guarantees or warranties of any kind are made as to its accuracy, suitability for particular applications or the results to be obtained. Other operational factors may also impact the service life of the hose. It is advisable to test the material under actual service conditions before specification. This information must not be used in conjunction with any other compatibility information from previous or future catalog editions, bulletins or publications. Incorrect use of these charts could result in death, personal injury or property damage.

FLUID COMPATIBILITY CHART

COMPATIBILITYKEY

- E = Excellent
- G = Good
- F = Fair
- X = Unsatisfactory
- * = No Data

CHEMICALS	SYNTHETIC RUBBER HOSE	THEMOPLASTIC HOSE
Hydrogen sulphide (dry)	X	E
I IODINE	F	*
Iso octance	E	E
Isopropyl Ether	G	*
Ispropyl Acetate	X	*
Ispropyl alcohol	G	E
J JET FUELS	E	E
K KEROSENE	E	E
KETONES	F	F
L LACQUER SOLVENTS	X	G
LACTIC ACID - COLD	X	G
LACTIC ACID - HOT	X	F
LAVENDER OIL	G	E
LEAD ACETATE	G	*
LEAD NITRATE	E	*
LEAD SULFATE	*	*
LIME	X	*
Lime Sulfur	X	*
LINOLEIC ACID	G	*
LINSEED OIL	E	E
LIQUID PETROLEUM GAS (LPG)	E	E
LUBRICATING OILS	G	E
LYE SOLUTIONS	G	*
M MAGNESIUM CHLORIDE	E	G
MAGNESIUM HYDROXIDE	G	G
MAGNESIUM SULFATE & SULPHITE	E	*
MALEIC ACID	X	*
MALIC ACID	F	*
Mercuric Chloride	G	G
MERCURY	E	E

⚠ WARNING: This information shall be intended only as reference to chemical compatibility with the internal fluid. No representations, guarantees or warranties of any kind are made as to its accuracy, suitability for particular applications or the results to be obtained. Other operational factors may also impact the service life of the hose. It is advisable to test the material under actual service conditions before specification. This information must not be used in conjunction with any other compatibility information from previous or future catalog editions, bulletins or publications. Incorrect use of these charts could result in death, personal injury or property damage.

PROPULSE HYDRAULIC MANUAL

FLUID COMPATIBILITY CHART

COMPATIBILITY KEY

E = Excellent
 G = Good
 F = Fair
 X = Unsatisfactory
 * = No Data

CHEMICALS	SYNTHETIC RUBBER HOSE	THEMOPLASTIC HOSE
MERCURY VAPORS	E	G
METHANOIC ACID	*	*
METHANOL (METHYL ALCOHOL)	E	E
METHYL ACETATE	X	*
Methyl Bromide	G	*
Methyl Butyl Ketone	X	E
METHYL CHLORIDE	X	X
METHYL CYANIDE	*	*
METHYL ETHYL KETONE	X	G
Methyl Isobutyl Ketone	X	G
Methyl Isopropyl Ketone	X	G
METHYL METHACRYLATE	X	*
Methyl Salicylate	X	*
Methylene Chloride	X	X
MINERAL OIL	E	A
MINERAL SPIRITS	E	*
MOLTEN SULFUR	*	G
MONOCHLOROBENZENE	X	*
MORPHOLINE	X	*
MOTOR OIL, 40 W	*	A
MURIATIC ACID	X	F
N NAPHTHA	F	E
NAPHTHALENE	X	G
NAPHTHENIC ACIDS	G	*
NATURAL GAS	E	E
NEON GAS	E	E
Nickel Acetate, 10% aq	G	*
NICKEL CHLORIDE	E	*
NICKEL NITRATE	*	*
NICKEL SULFATE	E	*

⚠ WARNING: This information shall be intended only as reference to chemical compatibility with the internal fluid. No representations, guarantees or warranties of any kind are made as to its accuracy, suitability for particular applications or the results to be obtained. Other operational factors may also impact the service life of the hose. It is advisable to test the material under actual service conditions before specification. This information must not be used in conjunction with any other compatibility information from previous or future catalog editions, bulletins or publications. Incorrect use of these charts could result in death, personal injury or property damage.

FLUID COMPATIBILITY CHART

COMPATIBILITYKEY

E = Excellent
 G = Good
 F = Fair
 X = Unsatisfactory
 * = No Data

CHEMICALS	SYNTHETIC RUBBER HOSE	THEMOPLASTIC HOSE
NITRIC ACID, 10 %	X	F
NITRIC ACID, 13 N	*	X
NITRIC ACID, 13 N + 5 %	*	X
NITRIC ACID, 20 %	X	X
NITRIC ACID, 30 %	X	X
NITRIC ACID, 30 % - 70 %	X	X
NITRIC ACID, CONC (16N)	X	X
NITRIC ACID, RED FUMING	X	X
NITROBENZENE	X	X
NITROETHANE	X	*
NITROGEN	E	E
NITROMETHANE	X	*
NITROUS OXIDE GAS	*	F
N-OCTANE	G	E
O Octyl Alcohol	G	E
OIL-PETROLEUM	E	E
OLEIC ACID	F	E
OLEUM (FUMING SULFIRIC ACID)	F	X
OLIVE OIL	E	E
ORTHO-DICHLOROBENZENE	X	*
ORTHOXYLENE	*	*
OXALIC ACID	X	*
Oxygen	G	G
OZONE	X	F
P PAINT THINNER	X	*
PALMITIC ACID	E	E
PAPERMAKERS ALUM	E	*
PARA-DICHLOROBENZENE	X	*
PARAFFIN WAX	E	E
PARALDEHYDE	*	*

⚠ WARNING: This information shall be intended only as reference to chemical compatibility with the internal fluid. No representations, guarantees or warranties of any kind are made as to its accuracy, suitability for particular applications or the results to be obtained. Other operational factors may also impact the service life of the hose. It is advisable to test the material under actual service conditions before specification. This information must not be used in conjunction with any other compatibility information from previous or future catalog editions, bulletins or publications. Incorrect use of these charts could result in death, personal injury or property damage.

PROPULSE HYDRAULIC MANUAL

FLUID COMPATIBILITY CHART

COMPATIBILITY KEY

E = Excellent
 G = Good
 F = Fair
 X = Unsatisfactory
 * = No Data

CHEMICALS	SYNTHETIC RUBBER HOSE	THERMOPLASTIC HOSE
PARAXYLENE	*	*
PENTACHLOROETHANE	*	*
PENTANE	E	E
PERCHLORIC ACID- 2 N	X	*
Perchloroethylene	G	*
PETROL (GASOLINE)	G	E
PHENOL	X	X
PHOSPHORIC ACID 10 %	X	X
PHOSPHORIC ACID 10 % - 85 %	X	X
PINE OIL	X	G
Potassium Acetate, 10% aq	G	*
POTASSIUM BISULFATE	*	*
POTASSIUM CARBONATE	*	*
POTASSIUM CHLORIDE	E	*
POTASSIUM CHROMATE	*	*
POTASSIUM CYANIDE	E	*
POTASSIUM DICHROMATE	E	G
POTASSIUM HYDROXIDE	X	E
Potassium Nitrate, 10% aq	E	*
POTASSIUM PERMANGANATE, 5 %	*	*
POTASSIUM SULFATE	E	*
PROPANE	E	E
Propyl Acetate	X	*
Propyl Alcohol	E	E
PROPYLENE	X	E
REFRIGERANT 11	G	G
REFRIGERANT 12	E	G
REFRIGERANT 22	X	G
S SAL AMMONIAC	E	*
SEA WATER	E	E

⚠ WARNING: This information shall be intended only as reference to chemical compatibility with the internal fluid. No representations, guarantees or warranties of any kind are made as to its accuracy, suitability for particular applications or the results to be obtained. Other operational factors may also impact the service life of the hose. It is advisable to test the material under actual service conditions before specification. This information must not be used in conjunction with any other compatibility information from previous or future catalog editions, bulletins or publications. Incorrect use of these charts could result in death, personal injury or property damage.

FLUID COMPATIBILITY CHART

COMPATIBILITYKEY

- E = Excellent
- G = Good
- F = Fair
- X = Unsatisfactory
- * = No Data

CHEMICALS	SYNTHETIC RUBBER HOSE	THEMOPLASTIC HOSE
SEWAGE	E	E
SILICONE OIL	E	G
SILVER NITRATE	G	*
SOAP SOLUTIONS	E	E
SODA ASH	E	*
SODA LIME	*	*
SODIUM ACETATE	G	*
SODIUM BICARBONATE	E	*
SODIUM BISULFATE	E	*
SODIUM BORATE	E	*
SODIUM CARBONATE	E	*
SODIUM CHLORIDE	E	E
SODIUM CYANIDE	E	*
SODIUM DICHROMATE	F	G
SODIUM HYDROXIDE (CAUSTIC SODA)	X	G
SODIUM HYPOCHLORITE	G	E
Sodium Metaphosphate, 10% aq	E	*
SODIUM NITRATE	G	*
Sodium Perborate, 10% aq	G	*
SODIUM PEROXIDE	G	*
SODIUM PHOSPHATE	E	*
Sodium Silicate, 10% aq	E	*
SODIUM SULFATE	E	*
Sodium Sulfide, 10% aq	E	*
Sodium Thiosulfate, 10% aq	G	*
SOYBEAN OIL	E	E
Stannic Chloride	E	G
STEAM, BELOW 350 DEG F	X	X
STEARIC ACID	G	G
Stoddard Solvent	E	*

⚠ WARNING: This information shall be intended only as reference to chemical compatibility with the internal fluid. No representations, guarantees or warranties of any kind are made as to its accuracy, suitability for particular applications or the results to be obtained. Other operational factors may also impact the service life of the hose. It is advisable to test the material under actual service conditions before specification. This information must not be used in conjunction with any other compatibility information from previous or future catalog editions, bulletins or publications. Incorrect use of these charts could result in death, personal injury or property damage.

PROPULSE HYDRAULIC MANUAL

FLUID COMPATIBILITY CHART

COMPATIBILITY KEY

E = Excellent
 G = Good
 F = Fair
 X = Unsatisfactory
 * = No Data

CHEMICALS	SYNTHETIC RUBBER HOSE	THERMOPLASTIC HOSE
STYRENE	X	X
SULFIRIC ACID 60 % (200F)	*	X
SULFIRIC ACID, 25 %	X	E
SULFIRIC ACID, 25 % - 50 %	X	E
SULFIRIC ACID, 50 % - 96 %	X	X
SULFIRIC ACID, CONC.	X	*
SULFIRIC ACID, FUMING	X	X
SULFUR	X	G
SULFUR CHLORIDE	F	*
SULFUR DIOXIDE	X	G
Sulfurous Acid	G	F
T Tannic Acid	G	E
TAR	X	*
TAR BITUMINOUS	G	*
TARTARIC ACID	E	G
TETRACHLOROBENZENE	*	*
TETRACHLOROETHANE	*	*
TETRACHLOROETHYLENE	X	*
TETRACHLOROMETHANE	*	*
TIN CHLORIDE	*	*
TITANIUM TETRACHLORIDE	G	*
TOLUENE	X	G
TRI CHLORO ETHYLENE	X	F
TRICHLOROACETIC ACID	G	*
Tricresyl Phosphate	X	*
Triethanolamine	G	*
TURPENTINE	X	*
U UREA	*	*
URETHANE FORMULATIONS	E	*
URIC ACID	*	*

⚠ WARNING: This information shall be intended only as reference to chemical compatibility with the internal fluid. No representations, guarantees or warranties of any kind are made as to its accuracy, suitability for particular applications or the results to be obtained. Other operational factors may also impact the service life of the hose. It is advisable to test the material under actual service conditions before specification. This information must not be used in conjunction with any other compatibility information from previous or future catalog editions, bulletins or publications. Incorrect use of these charts could result in death, personal injury or property damage.

FLUID COMPATIBILITY CHART

COMPATIBILITYKEY

- E = Excellent
- G = Good
- F = Fair
- X = Unsatisfactory
- * = No Data

CHEMICALS	SYNTHETIC RUBBER HOSE	THERMOPLASTIC HOSE
V VARNISH	G	*
VEGETABLE OILS	E	G
VINEGAR	X	G
VINEGAR ACID	*	G
VINYL ACETATE	*	*
VINYL BENZENE	*	*
VINYL CHLORIDE	X	*
VINYL CYANIDE	*	*
VINYL STYRENE	*	*
VINYL TOLUENE	*	*
W WATER	E	E
WATER, BOILING	F	X
WHISKEY	E	E
WINES	E	E
X Xylene	X	G
Z ZINC CHLORIDE	E	E
ZINC CHROMATE	*	*
ZINC SULFATE	E	*

⚠ WARNING: This information shall be intended only as reference to chemical compatibility with the internal fluid. No representations, guarantees or warranties of any kind are made as to its accuracy, suitability for particular applications or the results to be obtained. Other operational factors may also impact the service life of the hose. It is advisable to test the material under actual service conditions before specification. This information must not be used in conjunction with any other compatibility information from previous or future catalog editions, bulletins or publications. Incorrect use of these charts could result in death, personal injury or property damage.

PROPULSE HYDRAULIC MANUAL

CONVERSION TABLES

METRIC to ENGLISH EQUIVALENTS ENGLISH to METRIC EQUIVALENTS





inches x 25.4 = millimeters (mm)
 inches x 2.54 = centimeters (cm)
 feet x .3048 = meters (m)
 yard x .9144 = meters (m)
 psi x .0689 = bar
 psi x .0069 = Megapascals (MPa)
 psi x .0703 = Kilogram force per square centimeter (Kgf/cm)
 pound force x 4.448 = Newtons
 pound inch x .113 = Newton meters N * m
 pound foot x 1.356 = Newton meters N * m

millimeter x .0394 = inch (in)
 centimeter x .3937 = inch (in)
 meters x 3.281 = feet (ft)
 meters x 1.0936 = yards (yd)
 bar x 14.5 = psi
 Megapascals x 145.0 = psi
 Kilogram force per square centimeter x 14.22 = psi
 Newtons x .2248 = pounds force (lbf)
 Newton meter x 8.850 = pound * inches (lb * in)
 Newton meter x .737 = pound feet (lb * ft)

HOSE SIZE CONVERSION TABLE

HOSE SIZE			
DN	dash	mm	inch
3	-2	3.7	1/8"
5	-3	4.8	3/16"
6	-4	6.3	1/4"
8	-5	8.0	5/16"
10	-6	9.5	3/8"
12	-8	12.7	1/2"
16	-10	16,0	5/8"
19	-12	19.0	3/4"
25	16	25.4	1"
31	-20	32.0	1 1/4"
38	-24	38.0	1 1/2"
51	-32	50,8	2"
60	-38	60.0	2 3/8"
63	-40	63,5	2 1/2"
76	-48	76.2	3"
89	-56	88.9	3 1/2"
102	-64	101,6	4"

SYMBOL MEANING

Hose I.D. (Max)	
Hose O.D. (Max)	
Working Pressure	
Proof Pressure	
Minimum Burst Pressure	
Minimum Bend Radius	

PROPULSE HYDRAULIC MANUAL

HOW TO MEASURE ASSEMBLIES

HOW TO MEASURE THE LENGTH OF A CRIMPED HOSE ASSEMBLY

The overall length of the hose assembly is measured to the sealing surface of straight fittings or to the centerline of elbow fittings. See below:

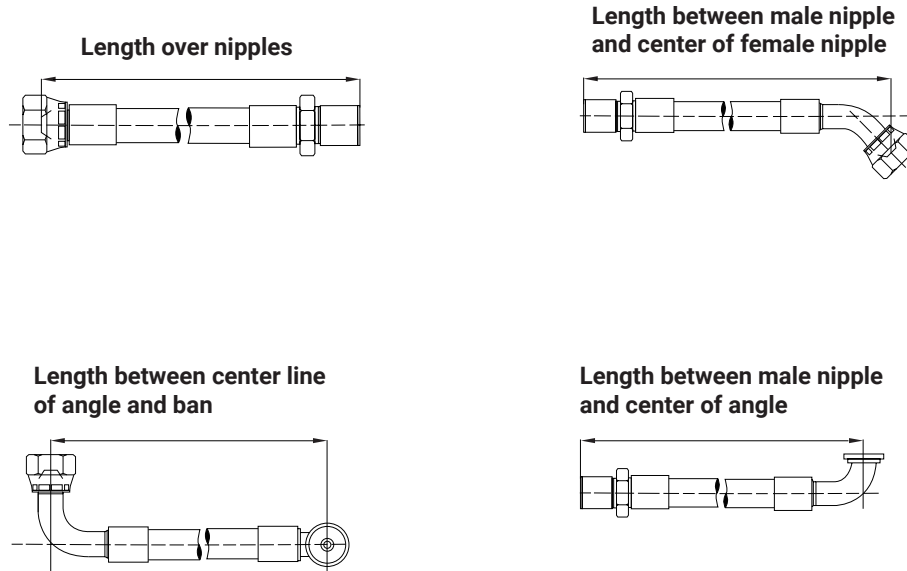

LENGTH TOLERANCES FOR HOSE ASSEMBLIES

Overall Assembly Length	Tolerance
Up to 300mm (11.811"), included	± 3mm (±0.118")
Over 300mm (11.811") through 450mm (17.717"), included	± 5mm (± 0.197")
Over 450mm (17.717") through 900mm (35.433"), included	± 7mm (± 0.276")
Over 900mm (35.433")	± 1%

*When not specified by customer print the above tolerances will be applied to all hose assemblies.

*These tolerances are standard as specified by the SAE J517 standard for hydraulic hose.

PROPULSE HYDRAULIC MANUAL

PRESSURE CONVERSIONS

PRESSURE CONVERSIONS

Kilo-Pascals (kPa)	Mega-Pascals (MPa)	Bar (bar)	Kilograms per Square Centimeter (Kgf/cm ²)	lbs per Square Inch (psi)
100	0.1	1.00	1.0	14.50
200	0.2	2.00	2.0	29.00
300	0.3	3.00	3.1	43.50
400	0.4	4.00	4.1	58.00
500	0.5	5.00	5.1	72.50
600	0.6	6.00	6.1	87.00
700	0.7	7.00	7.1	101.50
800	0.8	8.00	8.2	116.00
900	0.9	9.00	9.2	130.50
1000	1.0	10.00	10.2	145.00
2000	2.0	20.00	20.4	290.10
3000	3.0	30.00	30.6	435.10
4000	4.0	40.00	40.8	580.20
5000	5.0	50.00	51.0	725.20
6000	6.0	60.00	61.2	870.20
7000	7.0	70.00	71.4	1015.30
8000	8.0	80.00	81.6	1160.30
9000	9.0	90.00	91.8	1305.30
10000	10.0	100.00	102.0	1450.00
20000	20.0	200.00	204.0	2901.00
30000	30.0	300.00	306.0	4351.00
40000	40.0	400.00	408.0	5802.00
50000	50.0	500.00	510.0	7252.00
60000	60.0	600.00	612.0	8702.00
70000	70.0	700.00	714.0	10153.00
80000	80.0	800.00	816.0	11603.00
90000	90.0	900.00	918.0	13053.00
100000	100.0	1000.00	1020.0	14504.00
200000	200.0	2000.00	2040.0	29008.00
300000	300.0	3000.00	3060.0	43511.00

lbs per Square Inch (psi)	Kilo-Pascals (kPa)	Mega-Pascals (MPa)	Bar (bar)	Kilograms per Square Centimeter (Kgf/cm ²)
10	68.9	0.07	0.7	0.70
20	137.9	0.14	1.4	1.41
30	206.8	0.21	2.1	2.11
40	275.8	0.28	2.8	2.81
50	344.7	0.34	3.4	3.52
60	413.7	0.41	4.1	4.22
70	482.6	0.48	4.8	4.92
80	551.6	0.55	5.5	5.63
90	620.5	0.62	6.2	6.33
100	689.0	0.70	6.9	7.00
200	1379.0	1.40	13.8	14.10
300	2068.0	2.10	20.7	21.10
400	2758.0	2.80	27.6	28.10
500	3447.0	3.40	34.5	35.20
600	4137.0	4.10	41.4	42.20
700	4826.0	4.80	48.3	49.20
800	5516.0	5.50	55.2	56.30
900	6205.0	6.20	62.1	63.30
1000	6895.0	6.90	68.9	70.30
2000	13790.0	13.80	137.9	140.70
3000	20684.0	20.70	206.8	211.00
4000	27579.0	27.60	275.8	281.30
5000	34474.0	34.50	344.7	351.60
6000	41369.0	41.40	413.7	421.90
7000	48263.0	48.30	482.6	492.30
8000	55158.0	55.20	551.6	562.60
9000	62053.0	62.10	620.5	632.90
10000	68948.0	68.90	689.0	703.00
20000	137895.0	137.90	1379.0	1406.00
30000	206843.0	206.80	2068.0	2110.00
40000	275790.0	275.80	2758.0	2813.00

WORKING PRESSURE HOSE SELECTION

		WORKING PRESSURE (psi)											
HOSE SIZE	DN	3	5	6	8	10	12	16	19	25	31	38	51
	DASH	- 2	- 3	- 4	- 5	- 6	- 8	- 10	- 12	- 16	- 20	- 24	- 32
	INCH	1/8	3/16	1/4	5/16	3/8	1/2	5/8	3/4	1	1 1/4	1 1/2	2
100 SERIES			3625	3262	3117	2610	2300	1885	1522	1276	913	725	580
200 SERIES				5800	5075	4785	3987	3625	3117	2392	1812	1305	1160
400 SERIES									300	250	200	150	100
700 SERIES		3000	3000	2750	2500	2250	2000						
700NC SERIES		3000	3000	2750	2500	2250	2000						
800 SERIES		6000	5000	5000		4000	3500						
800NC SERIES		6000	5000	5000		4000	3500						
1200 SERIES						4060	4060	4060	4060	4060	3045		
1300 SERIES									5075	5075	5075	5075	5075
1500 SERIES						6090	6090		6090	6090	6090	6090	
1600 SERIES				5800	5075	4785	3987	3687	3117	2392	1812		
1700 SERIES				3045	3045	3045	3045	3045	3045	3045			
1800 SERIES		3045	3045	3045	3045	3045	3045	3045	3045	3045			
1900 SERIES				4060		4060	4060	4060	4060				
1SC SERIES				3262	3117	2610	2320	1885	1522	1276			
2SC SERIES				5800	5075	4785	3988	3625	3118	2393			
4SH SERIES									6090	5510	4700	4200	3625
4SP SERIES						6450	6020	5075	5075	4060	3045		
1TE SERIES			363	363	290	290	232	232					
2TE SERIES			1160	1087	986	913	841	725	652	580			
3TE SERIES			2320	2102	1885	1595	1348	1160	1015	797			
ARM SERIES				5800		4785	4045	3987	3117				

PROPULSE HYDRAULIC MANUAL

HOSE INDEX

HOSE INDEX

HOSE SERIES	DESCRIPTION	PAGE
100 SERIES	SAE 100R1 AT EN853 1SN	15
200 SERIES	SAE 100R2 AT EN853 1SN	16
400 SERIES	SAE 100R4	17
700 SERIES	SAE 100R7 EN855 R7	18
700NC SERIES	SAE 100R7 EN855 R7	19
800 SERIES	SAE 100R8 EN855 R8	20
800NC SERIES	SAE 100R8 EN855 R8	21
1200 SERIES	SAE 100R12 EN856 R12	22
1300 SERIES	SAE 100R13 EN856 R13	23
1500 SERIES	SAE 100R15	24
1600 SERIES	SAE 100R16	25
1700 SERIES	SAE 100R17	26
1800 SERIES	SAE 100R18	27
1900 SERIES	SAE 100R19	28
1SC SERIES	EN857 1SC	29
2SC SERIES	EN857 2SC	30
4SH SERIES	EN856 4SH	31
4SP SERIES	EN856 4SP	32
1TE SERIES	EN854 1TE	33
2TE SERIES	EN854 2TE	34
3TE SERIES	EN854 3TE	35
ARM SERIES	EN857 2SC	36

PROPULSE HYDRAULIC MANUAL

FITTING INDEX

FITTING INDEX

FITTING SERIES	DESCRIPTION	PAGE
22611 SERIES	Metric Female 24° Cone O-Ring DKOL Straight DIN 20066/3865	37
22641 SERIES	Metric Female 24° Cone O-Ring DKOL 45° Elbow DIN 20066/3865	38
22691 SERIES	Metric Female 24° Cone O-Ring DKOL 90° Elbow DIN 20066/3865	39
12611 SERIES	Metric Male 24° Cone Seat DKOL Straight DIN 20066/3861	40
22711 SERIES	Metric Female 24° Cone O-Ring DKOS Straight DIN 20066/3865	41
22741 SERIES	Metric Female 24° Cone O-Ring DKOS 45° Elbow DIN 20066/3865	42
22791 SERIES	Metric Female 24° Cone O-Ring DKOS 90° Elbow DIN 20066/3865	43
12711 SERIES	Metric Male 24° Cone Seat DKOS Straight DIN 20066/3861	44
72211 SERIES	Metric Banjo DIN 7642	45
26411S SERIES	ORFS Female Short Straight SAE J1453/J516	46
26411L SERIES	ORFS Female Long Straight SAE J1453/J516	47
26441 SERIES	ORFS Female 45° Elbow SAE J1453/J516	48
26491 SERIES	ORFS Female 90° Elbow SAE J1453/J516	49
26491M SERIES	ORFS Female 90° Elbow Medium Drop SAE J1453/J516	50
26491L SERIES	ORFS Female 90° Elbow Long Drop SAE J1453/J516	51
16411 SERIES	ORFS Male Straight SAE J1453/J516	52
28911D SERIES	JIC Female 74° Cone Double Hex Straight SAE J514/J516	53
28941 SERIES	JIC Female 74° Cone 45° Elbow SAE J514/J516	54
28991 SERIES	JIC Female 37° Cone 90° Elbow SAE J514/J516	55
28991M SERIES	JIC Female 37° Cone 90° Elbow Medium Drop SAE J514/J516	56
28991L SERIES	JIC Female 37° Cone 90° Elbow Long Drop SAE J514/J516	57
18911 SERIES	JIC Male 37° Cone Straight SAE J514/J516	58
17811 SERIES	NPTF Male 30° Cone Straight SAE J516	59
17811W SERIES	NPTF Swivel Male 30° Cone Straight SAE J516	60
27811 SERIES	NPT Female Solid Straight	61
23811 SERIES	NPSM Female 30° Cone Straight	62
24811 SERIES	BSP Female 60° Cone Straight	63
24841 SERIES	BSP Female 60° Cone 45° Elbow	64
24891 SERIES	BSP Female 60° Cone 90° Elbow	65
14811 SERIES	BSP Male 60° Cone Straight	66
14411 SERIES	BSPP Male O-Ring Flat Straight	67
24411 SERIES	BSP Female Flat Seal Straight	68

PROPULSE HYDRAULIC MANUAL

FITTING INDEX

FITTING INDEX

FITTING SERIES	DESCRIPTION	PAGE
15211 SERIES	BSPT Male Straight	69
74211 SERIES	BSP Banjo	70
89511 SERIES	SAE Code 61 3000PSI Flange Straight SAE J516/J518	71
89541 SERIES	SAE Code 61 3000PSI Flange 45° Elbow SAE J516/J518	72
89591 SERIES	SAE Code 61 3000PSI Flange 90° Elbow SAE J516/J518	73
89811 SERIES	SAE Code 62 6000PSI Flange Straight SAE J516/J518	74
89841 SERIES	SAE Code 62 6000PSI Flange 45° Elbow SAE J516/J518	75
89891 SERIES	SAE Code 62 3000PSI Flange 90° Elbow SAE J516/J518	76
18211 SERIES	Standard ORB Male Solid SAE J514/J516	77
18211W SERIES	Standard ORB Male Swivel SAE J514/J516	78
33313 SERIES	Pressure Washer Nipple	79
23313LS SERIES	M22 Live Swivel	80
17813LS SERIES	NPT Live Swivel	80

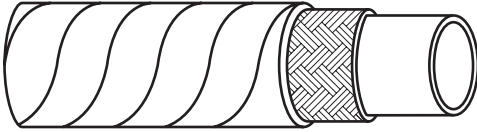

SAE 100R1 / EN853 TYPE 1SN ISO 1463-1 / R1AT Rubber Hydraulic Hose

100 SERIES															
	Hose Size			Hose I.D. (Max)		Hose O.D. (Max)		Working Pressure		Proof Pressure		Burst Pressure		Bend Radius (Min)	
ProPulse Hose Part No.	DN	dash	inch	mm	inch	mm	inch	bar	psi	bar	psi	bar	psi	mm	inch
100 - 03	5	-3	3/16	5.4	0.21	12.5	0.49	250	3625	500	7250	1000	14500	90	3.54
100 - 04	6	-4	1/4	7.0	0.28	14.1	0.56	225	3262	450	6524	900	13050	100	3.94
100 - 05	8	-5	5/16	8.5	0.33	15.7	0.62	215	3117	430	6234	860	12470	115	4.53
100 - 06	10	-6	3/8	10.1	0.40	18.1	0.71	180	2610	360	5220	720	10440	125	4.92
100 - 08	12	-8	1/2	13.5	0.53	21.5	0.85	160	2300	320	4600	640	9280	180	7.09
100 - 10	16	-10	5/8	16.7	0.66	24.7	0.97	130	1885	260	3770	520	7540	205	8.07
100 - 12	19	-12	3/4	19.8	0.78	28.6	1.13	105	1522	210	3044	420	6090	240	9.45
100 - 16	25	-16	1	26.4	1.04	36.6	1.44	88	1276	176	2552	352	5104	300	11.81
100 - 20	31	-20	1 1/4	33.0	1.30	44.8	1.76	63	913	126	1826	252	3654	420	16.54
100 - 24	38	-24	1 1/2	39.3	1.55	52.0	2.05	50	725	100	1450	200	2900	500	19.69
100 - 32	51	-32	2	52.0	2.05	65.9	2.59	40	580	80	1160	160	2320	630	24.80

HOSE CONSTRUCTION:

- › Inner Tube: Oil and water resistant synthetic rubber
- › Reinforcement: One layer of high tensile steel braid
- › Cover: Oil, abrasion and weather resistant synthetic rubber

MAIN APPLICATIONS: Low to medium pressure hydraulic and return lines.

TEMPERATURE RANGE:

- › -40°F / +212°F
- › -40°C / +100°C

INTERMITTENT SERVICE:

- › -40°F / +257°F
- › -40°C / +125°C

FULLY MEETS OR EXCEEDS THE FOLLOWING SPECIFICATION(S):

- › EN 853 1SN
- › ISO1436-1 1SN / R1AT
- › SAE 100R1AT
- › SAE 100R1S

NOTE: Not all sizes stocked at all times. Some specifications may vary.

PROPULSE HOSE SOLUTIONS

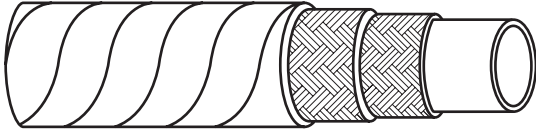

SAE 100R2 / EN853 TYPE 2SN
ISO 1436-1 2SN / R2AT Rubber Hydraulic Hose

200 SERIES															
	Hose Size			Hose I.D. (Max)		Hose O.D. (Max)		Working Pressure		Proof Pressure		Burst Pressure		Bend Radius (Min)	
	DN	dash	inch	mm	inch	mm	inch	bar	psi	bar	psi	bar	psi	mm	inch
200 - 04	06	-04	1/4	7.0	0.28	15.7	0.62	400	5800	800	11600	1600	23200	100	3.94
200 - 05	08	-05	5/16	8.5	0.33	17.3	0.68	350	5075	700	10150	1400	20300	115	4.53
200 - 06	10	-06	3/8	10.1	0.40	19.7	0.78	330	4785	660	9570	1320	19140	125	4.92
200 - 08	12	-08	1/2	13.5	0.53	23.0	0.91	275	3987	550	7974	1100	15950	180	7.09
200 - 10	16	-10	5/8	16.7	0.66	26.2	1.03	250	3625	500	7250	1000	14500	205	8.07
200 - 12	19	-12	3/4	19.8	0.78	30.1	1.19	215	3117	430	6234	860	12470	240	9.45
200 - 16	25	-16	1	26.4	1.04	38.9	1.53	165	2392	330	4784	660	9570	300	11.81
200 - 20	31	-20	1 1/4	33.0	1.30	49.5	1.95	125	1812	250	3624	500	7250	420	16.54
200 - 24	38	-24	1 1/2	39.3	1.55	55.9	2.20	90	1305	180	2610	360	5220	500	19.69
200 - 32	51	-32	2	52.0	2.05	68.6	2.70	80	1160	160	2320	320	4640	630	24.80

HOSE CONSTRUCTION:

- › Inner Tube: Oil and water resistant synthetic rubber
- › Reinforcement: Two layers of high tensile steel braid
- › Cover: Oil, abrasion and weather resistant synthetic rubber

MAIN APPLICATIONS: Medium to high pressure hydraulic application.

TEMPERATURE RANGE:

- › -40°F / +212°F
- › -40°C / +100°C

INTERMITTENT SERVICE:

- › -40°F / +257°F
- › -40°C / +125°C

FULLY MEETS OR EXCEEDS THE FOLLOWING SPECIFICATION(S):

- › EN 853 2SN
- › ISO 1436-1 2SN / R2AT
- › SAE 100R2AT
- › SAE 100R2S

NOTE: Not all sizes stocked at all times. Some specifications may vary.

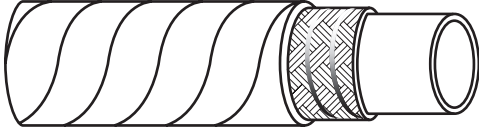

SAE 100R4 Rubber Hydraulic Suction Hose

400 SERIES	Hose Size		Hose I.D. (Max)		Hose O.D. (Max)		Working Pressure		Proof Pressure		Burst Pressure		Bend Radius (Min)		
	DN	dash	inch	mm	inch	mm	inch	bar	psi	bar	psi	bar	psi	mm	inch
400 - 12	19	-12	3/4	19.8	0.78	34.9	1.37	21	300	42	600	83	1200	125	5
400 - 16	25	-16	1	26.2	1.03	41.3	1.63	17	250	34	500	69	1000	150	6
400 - 20	31	-20	1 1/4	33.0	1.30	50.8	2.00	14	200	28	400	55	800	200	8
400 - 24	38	-24	1 1/2	39.3	1.55	57.2	2.25	10.5	150	21	300	41	600	254	10
400 - 32	51	-32	2	52.4	2.06	69.8	2.75	7	100	14	200	28	400	300	12

HOSE CONSTRUCTION:

- › Inner Tube: Oil resistant synthetic rubber
- › Reinforcement: High tensile textile cords with embedded steel wire helices
- › Cover: Neoprene, oil, abrasion and weather resistant synthetic rubber

MAIN APPLICATIONS: Low pressure hydraulic return or suction line.

TEMPERATURE RANGE:

- › -40°F / +212°F
- › -40°C / +100°C

INTERMITTENT SERVICE:

- › -40°F / +257°F
- › -40°C / +125°C

FULLY MEETS OR EXCEEDS THE FOLLOWING SPECIFICATION(S):

- › SAE 100R4

NOTE: Not all sizes stocked at all times. Some specifications may vary.

PROPULSE HOSE SOLUTIONS

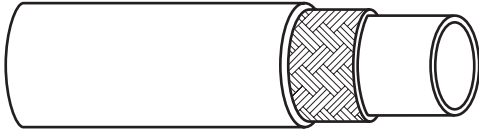

SAE 100R7 / EN855 R7 Thermoplastic Hydraulic Hose

700 SERIES															
	Hose Size			Hose I.D. (Max)		Hose O.D. (Max)		Working Pressure		Proof Pressure		Burst Pressure		Bend Radius (Min)	
	DN	dash	inch	mm	inch	mm	inch	bar	psi	bar	psi	bar	psi	mm	inch
700 - 02	03	-02	1/8	3.7	0.15	8	0.31	210	3000	420	6000	840	12000	25	0.98
700 - DN4	04	-02.5	1/8	4.1	0.16	9.5	0.37	210	3000	420	6000	840	12000	25	0.98
700 - 03	05	-03	3/16	5.4	0.21	11.4	0.45	210	3000	420	6000	840	12000	90	3.54
700 - 04	06	-04	1/4	7.0	0.28	13.7	0.54	192	2750	384	5500	768	11000	100	3.94
700 - 05	08	-05	5/16	8.5	0.33	15.6	0.61	175	2500	350	5000	700	10000	115	4.53
700 - 06	10	-06	3/8	10.3	0.41	18.4	0.72	157	2250	314	4500	628	9000	125	4.92
700 - 08	12	-08	1/2	13.5	0.53	22.5	0.89	140	2000	280	4000	560	8000	180	7.09

HOSE CONSTRUCTION:

- › Inner Tube: Oil resistant thermoplastic
- › Reinforcement: One or two layers of high tenacity yarn
- › Cover: Thermoplastic elastomer with high ozone and abrasion resistance (pin pricked cover upon request)

MAIN APPLICATIONS: Medium pressure hydraulic applications that require high flexibility, tight bend radius, good abrasion resistance, and good resistance to ozone and weathering.

TEMPERATURE RANGE:

- › -40°F / +200°F
- › -40°C / +93°C

INTERMITTENT SERVICE:

- › -40°F / +212°F
- › -40°C / +100°C

FULLY MEETS OR EXCEEDS THE FOLLOWING SPECIFICATION(S):

- › SAE 100R7
- › EN 855 R7

NOTE: Not all sizes stocked at all times. Some specifications may vary.



SAE 100R7 / EN855 R7 NON CONDUCTIVE Thermoplastic Hydraulic Hose

700NC SERIES	Hose Size		Hose I.D. (Max)		Hose O.D. (Max)		Working Pressure		Proof Pressure		Burst Pressure		Bend Radius (Min)		
	DN	dash	inch	mm	inch	mm	inch	bar	psi	bar	psi	bar	psi	mm	inch
700NC - 02	03	-02	1/8	3.7	0.15	8	0.31	210	3000	420	6000	840	12000	25	0.98
700NC - 03	05	-03	3/16	5.4	0.21	11.4	0.45	210	3000	420	6000	840	12000	90	3.54
700NC - 04	06	-04	1/4	7.0	0.28	13.7	0.54	192	2750	384	5500	768	11000	100	3.94
700NC - 05	08	-05	5/16	8.5	0.33	15.6	0.61	175	2500	350	5000	700	10000	115	4.53
700NC - 06	10	-06	3/8	10.3	0.41	18.4	0.72	157	2250	314	4500	628	9000	125	4.92
700NC - 08	12	-08	1/2	13.5	0.53	22.5	0.89	140	2000	280	4000	560	8000	180	7.09

HOSE CONSTRUCTION:

- › Inner Tube: Oil resistant thermoplastic
- › Reinforcement: One or two layers of high tenacity yarn
- › Cover: Thermoplastic elastomer with high ozone and abrasion resistance (cover **not** available pin pricked)
- › Cover Color: Orange
- › Complies with federal standard 595 and color chip reference #22510
- › Hose has passed Electrical Conductivity testing as dened in SAE J 517

MAIN APPLICATIONS: Medium pressure non-conductive hydraulic applications that require high flexibility, tight bend radius, good abrasion resistance, and good resistance to ozone and weathering such as lifts and cherry picker applications.

TEMPERATURE RANGE:

- › -40°F / +200°F
- › -40°C / +93°C

INTERMITTENT SERVICE:

- › -40°F / +212°F
- › -40°C / +100°C

FULLY MEETS OR EXCEEDS THE FOLLOWING SPECIFICATION(S):

- › SAE 100R7 (Non Conductive)
- › EN 855 R7 (Non Conductive)

NOTE: Not all sizes stocked at all times. Some specifications may vary.

PROPULSE HOSE SOLUTIONS

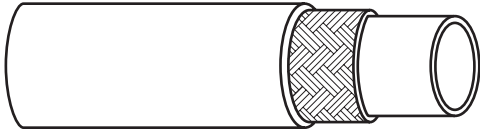

SAE 100R8 / EN855 R8 Thermoplastic Hydraulic Hose

800 SERIES															
	Hose Size			Hose I.D. (Max)		Hose O.D. (Max)		Working Pressure		Proof Pressure		Burst Pressure		Bend Radius (Min)	
	ProPulse Hose Part No.	DN	dash	inch	mm	inch	mm	inch	bar	psi	bar	psi	bar	psi	mm
800 - 02	03	-02	1/8	3.7	0.15	10.5	0.41	420	6000	840	12000	1680	24000	25	0.98
800 - 03	05	-03	3/16	5.4	0.21	14.6	0.57	350	5000	700	10000	1400	20000	90	3.54
800 - 04	06	-04	1/4	7.0	0.28	16.8	0.66	350	5000	700	10000	1400	20000	100	3.94
800 - 06	10	-06	3/8	10.3	0.41	20.3	0.80	280	4000	560	8000	1120	16000	125	4.92
800 - 08	12	-08	1/2	13.5	0.53	24.6	0.97	245	3500	490	7000	980	14000	180	7.09

HOSE CONSTRUCTION:

- › Inner Tube: Oil resistant thermoplastic
- › Reinforcement: One or two layers of high tenacity yarn
- › Cover: Thermoplastic elastomer with high ozone and abrasion resistance (pin pricked cover upon request)

MAIN APPLICATIONS: High pressure hydraulic applications that require high flexibility, tight bend radius, good abrasion resistance, and good resistance to ozone and weathering.

TEMPERATURE RANGE:

- › -40°F / +200°F
- › -40°C / +93°C

INTERMITTENT SERVICE:

- › -40°F / +212°F
- › -40°C / +100°C

FULLY MEETS OR EXCEEDS THE FOLLOWING SPECIFICATION(S):

- › SAE 100R8
- › EN 855 R8

NOTE: Not all sizes stocked at all times. Some specifications may vary.



SAE 100R8 / EN855 R8 NON CONDUCTIVE Thermoplastic Hydraulic Hose

800NC SERIES	Hose Size		Hose I.D. (Max)		Hose O.D. (Max)		Working Pressure		Proof Pressure		Burst Pressure		Bend Radius (Min)		
	DN	dash	inch	mm	inch	mm	inch	bar	psi	bar	psi	bar	psi	mm	inch
800NC - 02	03	-02	1/8	3.7	0.15	10.5	0.41	420	6000	840	12000	1680	24000	25	0.98
800NC - 03	05	-03	3/16	5.4	0.21	14.6	0.57	350	5000	700	10000	1400	20000	90	3.54
800NC - 04	06	-04	1/4	7.0	0.28	16.8	0.66	350	5000	700	10000	1400	20000	100	3.94
800NC - 06	10	-06	3/8	10.3	0.41	20.3	0.80	280	4000	560	8000	1120	16000	125	4.92
800NC - 08	12	-08	1/2	13.5	0.53	24.6	0.97	245	3500	490	7000	980	14000	180	7.09

HOSE CONSTRUCTION:

- › Inner Tube: Oil resistant thermoplastic
- › Reinforcement: One or two layers of high tenacity yarn
- › Cover: Thermoplastic elastomer with high ozone and abrasion resistance (pin pricked cover **not** available)
- › Cover Color: Orange
- › Complies with federal standard 595 and color chip reference #22510
- › Hose has passed Electrical Conductivity testing as dened in SAE J 517

MAIN APPLICATIONS: High pressure non conductive hydraulic applications that require high flexibility, tight bend radius, good abrasion resistance, and good resistance to weather and ozone such as lifts and cherry picker applications.

TEMPERATURE RANGE:

- › -40°F / +200°F
- › -40°C / +93°C

INTERMITTENT SERVICE:

- › -40°F / +212°F
- › -40°C / +100°C

FULLY MEETS OR EXCEEDS THE FOLLOWING SPECIFICATION(S):

- › SAE 100R8 (Non Conductive)
- › EN 855 R8 (Non Conductive)

NOTE: Not all sizes stocked at all times. Some specifications may vary.

PROPULSE HOSE SOLUTIONS

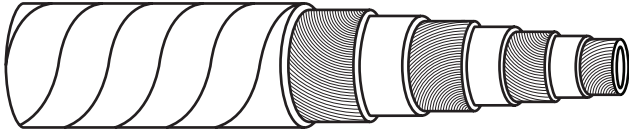

**SAE 100R12 / EN856 R12
Multi-Spiral Rubber Hydraulic Hose**

1200 SERIES	Hose Size		Hose I.D. (Max)		Hose O.D. (Max)		Working Pressure		Proof Pressure		Burst Pressure		Bend Radius (Min)		
	DN	dash	inch	mm	inch	mm	inch	bar	psi	bar	psi	bar	psi	mm	inch
1200 - 06	10	-06	3/8	10.1	0.40	21	0.83	280	4060	560	8120	1120	16240	125	4.92
1200 - 08	12	-08	1/2	13.5	0.53	24.6	0.97	280	4060	560	8120	1120	16240	180	7.09
1200 - 10	16	-10	5/8	16.7	0.66	28.2	1.11	280	4060	560	8120	1120	16240	200	7.87
1200 - 12	19	-12	3/4	19.8	0.78	31.5	1.24	280	4060	560	8120	1120	16240	240	9.45
1200 - 16	25	-16	1	26.4	1.04	39.2	1.54	280	4060	560	8120	1120	16240	300	11.81
1200 - 20	31	-20	1 1/4	33.0	1.30	48.6	1.91	210	3045	420	6090	840	12180	420	16.54

HOSE CONSTRUCTION:

- › Inner Tube: Oil resistant synthetic rubber
- › Reinforcement: Four high tensile steel spirals
- › Cover: Abrasion and weather resistant synthetic rubber

MAIN APPLICATIONS: Medium pressure heavy duty, high impulse, high temperature.

TEMPERATURE RANGE:

- › -40°F / +250°F
- › -40°C / +121°C

FULLY MEETS OR EXCEEDS THE FOLLOWING SPECIFICATION(S):

- › SAE 100R12
- › EN 856 R12
- › ISO 3862-1 R12

NOTE: Not all sizes stocked at all times. Some specifications may vary.

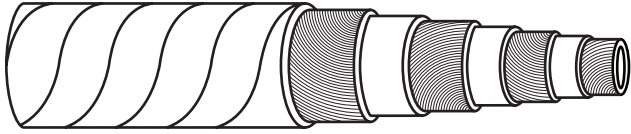

**SAE 100R13 / EN856 R13
Multi-Spiral Rubber Hydraulic Hose**

1300 SERIES	Hose Size		Hose I.D. (Max)		Hose O.D. (Max)		Working Pressure		Proof Pressure		Burst Pressure		Bend Radius (Min)		
	DN	dash	inch	mm	inch	mm	inch	bar	psi	bar	psi	bar	psi	mm	inch
1300 - 12	19	-12	3/4	19.8	0.78	33.2	1.31	350	5075	700	10150	1400	20300	240	9.45
1300 - 16	25	-16	1	26.4	1.04	39.8	1.57	350	5075	700	10150	1400	20300	300	11.81
1300 - 20	31	-20	1 1/4	33.0	1.30	51.3	2.02	350	5075	700	10150	1400	24300	420	16.54
1300 - 24	38	-24	1 1/2	39.3	1.55	58.8	2.31	350	5075	700	10150	1400	24300	500	19.69
1300 - 32	51	-32	2	52.0	2.05	72.7	2.86	350	5075	700	10150	1400	24300	640	25.20

HOSE CONSTRUCTION:

- › Inner Tube: Oil resistant synthetic rubber
- › Reinforcement: Four or six high tensile steel spirals
- › Cover: Abrasion and weather resistant synthetic rubber

MAIN APPLICATIONS: High pressure, heavy duty, high impulse, high temperature.

TEMPERATURE RANGE:

- › -40°F / +250°F
- › -40°C / +121°C
- ›

FULLY MEETS OR EXCEEDS THE FOLLOWING SPECIFICATION(S):

- › SAE 100R13
- › EN 856 R13
- › ISO 3862-1 R13

NOTE: Not all sizes stocked at all times. Some specifications may vary.

PROPULSE HOSE SOLUTIONS

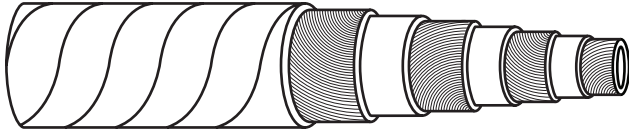

SAE 100R15 Multi-Spiral Rubber Hydraulic Hose

1500 SERIES	Hose Size		Hose I.D. (Max)		Hose O.D. (Max)		Working Pressure		Proof Pressure		Burst Pressure		Bend Radius (Min)		
	DN	dash	inch	mm	inch	mm	inch	bar	psi	bar	psi	bar	psi	mm	inch
1500 - 06	10	-06	3/8	10.1	0.40	23.3	0.92	420	6090	840	12180	1680	24360	150	5.90
1500 - 08	12	-08	1/2	13.5	0.53	26.8	1.06	420	6090	840	12180	1680	24360	200	7.87
1500 - 12	19	-12	3/4	19.8	0.78	36.1	1.42	420	6090	840	12180	1680	24360	265	10.43
1500 - 16	25	-16	1	26.4	1.04	42.9	1.69	420	6090	840	12180	1680	24360	330	12.99
1500 - 20	31	-20	1 1/4	33.0	1.30	51.5	2.03	420	6090	840	12180	1680	24360	445	17.52
1500 - 24	38	-24	1 1/2	39.3	1.55	59.6	2.35	420	6090	840	12180	1680	24360	530	20.87

HOSE CONSTRUCTION:

- › Inner Tube: Oil resistant synthetic rubber
- › Reinforcement: Four or six high tensile steel spirals
- › Cover: Abrasion and weather resistant synthetic rubber

MAIN APPLICATIONS: High pressure, heavy duty, high impulse, high temperature.

TEMPERATURE RANGE:

- › -40°F / +250°F
- › -40°C / +121°C

FULLY MEETS OR EXCEEDS THE FOLLOWING SPECIFICATION(S):

- › SAE 100R15
- › ISO 3862-1 R15

NOTE: Not all sizes stocked at all times. Some specifications may vary.

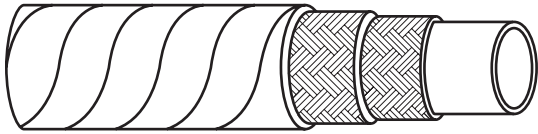

SAE 100R16 Compact Rubber Hydraulic Hose

1600 SERIES	Hose Size		Hose I.D. (Max)		Hose O.D. (Max)		Working Pressure		Proof Pressure		Burst Pressure		Bend Radius (Min)		
	DN	dash	inch	mm	inch	mm	inch	bar	psi	bar	psi	bar	psi	mm	inch
1600 - 04	6	-04	1/4	7.0	0.28	14.5	0.57	400	5800	800	11600	1600	23200	50	1.97
1600 - 05	8	-05	5/16	8.5	0.33	15.7	0.62	350	5075	700	10150	1400	20300	55	2.17
1600 - 06	10	-06	3/8	10.1	0.40	18.8	0.74	330	4785	660	9570	1320	19140	65	2.56
1600 - 08	12	-08	1/2	13.5	0.53	22.0	0.87	275	3987	550	7975	1100	15950	90	3.54
1600 - 10	16	-10	5/8	16.7	0.66	25.4	1.00	250	3625	500	7250	1000	14500	100	3.94
1600 - 12	19	-12	3/4	19.8	0.78	29.0	1.14	215	3117	430	6235	860	12470	120	4.72
1600 - 16	25	-16	1	26.4	1.04	36.6	1.44	165	2392	330	4785	660	9570	150	5.91
1600 - 20	31	-20	1 1/4	33.0	1.30	44.3	1.74	125	1812	250	3625	500	7250	210	8.27

HOSE CONSTRUCTION:

- › Inner Tube: Oil resistant synthetic rubber
- › Reinforcement: One or two layers of high tensile steel braid
- › Cover: Abrasion and weather resistant synthetic rubber

MAIN APPLICATIONS: Medium to high pressure applications. This hose is similar to the SAE100R2 / EN853 2SN, but has a smaller outside diameter which achieves a tighter bend radius while providing a lighter weight and compact design when minimal space is available.

TEMPERATURE RANGE:

- › -40°F / +212°F
- › -40°C / +100°C

INTERMITTENT SERVICE:

- › -40°F / +257°F
- › -40°C / +125°C

FULLY MEETS OR EXCEEDS THE FOLLOWING SPECIFICATION(S):

- › SAE 100R16 type S
- › ISO 11237-1 R16
- › ISO11237-1 2SC

NOTE: Not all sizes stocked at all times. Some specifications may vary.

PROPULSE HOSE SOLUTIONS

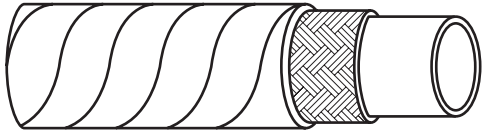

SAE 100R17 Compact Rubber Hydraulic Hose

1700 SERIES	Hose Size		Hose I.D. (Max)		Hose O.D. (Max)		Working Pressure		Proof Pressure		Burst Pressure		Bend Radius (Min)		
	DN	dash	inch	mm	inch	mm	inch	bar	psi	bar	psi	bar	psi	mm	inch
1700 - 04	06	-04	1/4	7.0	0.27	13.2	0.52	210	3045	420	6090	840	12180	50	1.97
1700 - 05	08	-05	5/16	8.5	0.33	15.0	0.59	210	3045	420	6090	840	12180	55	2.17
1700 - 06	10	-06	3/8	10.1	0.39	17.0	0.67	210	3045	420	6090	840	12180	65	2.56
1700 - 08	12	-08	1/2	13.5	0.53	21.1	0.83	210	3045	420	6090	840	12180	90	3.54
1700 - 10	16	-10	5/8	16.7	0.66	25.9	1.02	210	3045	420	6090	840	12180	100	3.94
1700 - 12	19	-12	3/4	19.8	0.78	30.3	1.19	210	3045	420	6090	840	12180	120	4.72
1700 - 16	25	-16	1	26.4	1.03	38.6	1.52	210	3045	420	6090	840	12180	150	5.91

HOSE CONSTRUCTION:

- › Inner Tube: Oil resistant synthetic rubber
- › Reinforcement: One or two layers of high tensile steel braid
- › Cover: Oil, abrasion and weather resistant synthetic rubber

MAIN APPLICATIONS: Medium pressure small bend radius hose that is highly flexible and specially designed for use when installation constraints are present.

TEMPERATURE RANGE:

- › -40°F / +212°F
- › -40°C / +100°C

INTERMITTENT SERVICE:

- › -40°F / +257°F
- › -40°C / +125°C

FULLY MEETS OR EXCEEDS THE FOLLOWING SPECIFICATION(S):

- › SAE 100R17
- › ISO 11237-1 R17

NOTE: Not all sizes stocked at all times. Some specifications may vary.

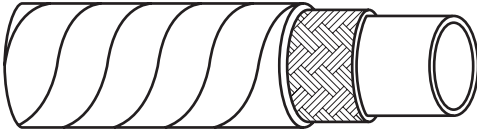

SAE 100R18 Thermoplastic Hydraulic Hose

1800 SERIES	Hose Size		Hose I.D. (Max)		Hose O.D. (Max)		Working Pressure		Proof Pressure		Burst Pressure		Bend Radius (Min)		
	DN	dash	inch	mm	inch	mm	inch	bar	psi	bar	psi	bar	psi	mm	inch
1800 - 02	03	-02	1/8	4.0	0.16	9.5	0.37	210	3045	420	6090	840	12180	25	0.98
1800 - 03	05	-03	3/16	5.4	0.21	10.8	0.43	210	3045	420	6090	840	12180	30	1.18
1800 - 04	06	-04	1/4	7.0	0.28	13.5	0.53	210	3045	420	6090	840	12180	45	1.77
1800 - 05	08	-05	5/16	8.5	0.33	16.6	0.65	210	3045	420	6090	840	12180	50	1.97
1800 - 06	10	-06	3/8	10.3	0.41	18.4	0.72	210	3045	420	6090	840	12180	75	2.95
1800 - 08	12	-08	1/2	13.5	0.53	22.8	0.90	210	3045	420	6090	840	12180	90	3.54
1800 - 10	16	-10	5/8	16.8	0.66	27.2	1.07	210	3045	420	6090	840	12180	125	4.92
1800 - 12	19	-12	3/4	19.8	0.78	31.5	1.24	210	3045	420	6090	840	12180	165	6.50
1800 - 16	25	-16	1	26.4	1.04	40.4	1.59	210	3045	420	6090	840	12180	250	9.84

HOSE CONSTRUCTION:

- › Inner Tube: Oil resistant thermoplastic
- › Reinforcement: One or two layers of high tenacity yarn
- › Cover: Oil resistant thermoplastic elastomer with high ozone and abrasion resistance (pin pricked cover upon request)

MAIN APPLICATIONS: Medium pressure hydraulic application that requires high flexibility, tight bend radius and good abrasion resistance to weather and ozone.

TEMPERATURE RANGE:

- › -40°F / +200°F
- › -40°C / +93°C

FULLY MEETS OR EXCEEDS THE FOLLOWING SPECIFICATION(S):

- › SAE 100R18

NOTE: Not all sizes stocked at all times. Some specifications may vary.

PROPULSE HOSE SOLUTIONS

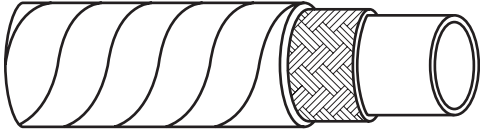

SAE 100R19 Compact Rubber Hydraulic Hose

1900 SERIES	Hose Size		Hose I.D. (Max)		Hose O.D. (Max)		Working Pressure		Proof Pressure		Burst Pressure		Bend Radius (Min)		
	DN	dash	inch	mm	inch	mm	inch	bar	psi	bar	psi	bar	psi	mm	inch
1900 - 04	06	-04	1/4	7.0	0.27	14.4	0.57	280	4060	560	8120	1120	16240	50	1.97
1900 - 06	10	-06	3/8	10.1	0.39	18.0	0.71	280	4060	560	8120	1120	16240	65	2.56
1900 - 08	12	-08	1/2	13.5	0.53	22.6	0.89	280	4060	560	8120	1120	16240	90	3.54
1900 - 10	16	-10	5/8	16.7	0.66	27.5	1.08	280	4060	560	8120	1120	16240	100	3.94
1900 - 12	19	-12	3/4	19.8	0.78	32.5	1.28	280	4060	560	8120	1120	16240	120	4.72

HOSE CONSTRUCTION:

- › Inner Tube: Oil resistant synthetic rubber
- › Reinforcement: One or two layers of high tensile steel braid
- › Cover: Oil, abrasion and weather resistant synthetic rubber

MAIN APPLICATIONS: High pressure small bend radius hose that is highly flexible and specifically designed for use when installation constraints are present.

TEMPERATURE RANGE:

- › -40°F / +212°F
- › -40°C / +100°C

INTERMITTENT SERVICE:

- › -40°F / +257°F
- › -40°C / +125°C

FULLY MEETS OR EXCEEDS THE FOLLOWING SPECIFICATION(S):

- › SAE 100R19

NOTE: Not all sizes stocked at all times. Some specifications may vary.

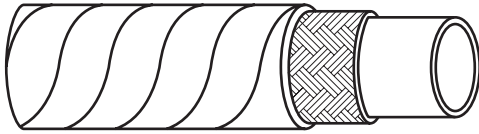

EN857 1SC Compact Rubber Hydraulic Hose

1SC SERIES	Hose Size		Hose I.D. (Max)		Hose O.D. (Max)		Working Pressure		Proof Pressure		Burst Pressure		Bend Radius (Min)		
	DN	dash	inch	mm	inch	mm	inch	bar	psi	bar	psi	bar	psi	mm	inch
1SC - 04	06	-04	1/4	6.9	0.27	13.5	0.53	225	3262	450	6524	900	13050	75	2.95
1SC - 05	08	-05	5/16	8.5	0.33	14.5	0.57	215	3117	430	6235	860	12470	85	3.35
1SC - 06	10	-06	3/8	10.1	0.40	16.9	0.67	180	2610	360	5220	720	10440	90	3.54
1SC - 08	12	-08	1/2	13.5	0.53	20.4	0.80	160	2320	320	4640	640	9280	130	5.12
1SC - 10	16	-10	5/8	16.7	0.66	23.0	0.91	130	1885	260	3770	520	7540	150	5.91
1SC - 12	19	-12	3/4	19.8	0.78	26.7	1.05	105	1522	210	3045	420	6090	180	7.09
1SC - 16	25	-16	1	26.4	1.04	34.9	1.37	88	1276	176	2552	352	5104	230	9.06

HOSE CONSTRUCTION:

- › Inner Tube: Oil resistant synthetic rubber
- › Reinforcement: One layer of high tensile steel braid
- › Cover: Oil, abrasion and weather resistant synthetic rubber

MAIN APPLICATIONS: Low to medium pressure lines that require tight bend radius.

TEMPERATURE RANGE:

- › -40°F / +212°F
- › -40°C / +100°C

INTERMITTENT SERVICE:

- › -40°F / +257°F
- › -40°C / +125°C

FULLY MEETS OR EXCEEDS THE FOLLOWING SPECIFICATION(S):

- › EN 857 1SC
- › ISO 11237-1 1SC

NOTE: Not all sizes stocked at all times. Some specifications may vary.

PROPULSE HOSE SOLUTIONS

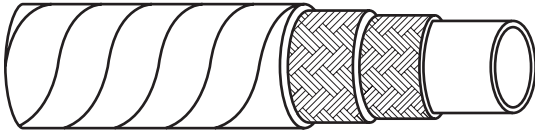

EN857 2SC Compact Rubber Hydraulic Hose

2SC SERIES	Hose Size		Hose I.D. (Max)		Hose O.D. (Max)		Working Pressure		Proof Pressure		Burst Pressure		Bend Radius (Min)		
	DN	dash	inch	mm	inch	mm	inch	bar	psi	bar	psi	bar	psi	mm	inch
2SC - 04	06	-04	1/4	6.9	0.27	14.2	0.56	400	5800	800	11600	1600	23200	75	2.95
2SC - 05	08	-05	5/16	8.5	0.33	16.0	0.63	350	5075	700	10150	1400	20300	85	3.35
2SC - 06	10	-06	3/8	10.1	0.40	18.3	0.72	330	4785	660	9570	1320	19140	90	3.54
2SC - 08	12	-08	1/2	13.5	0.53	21.5	0.85	275	3988	550	7975	1100	15950	130	5.12
2SC - 10	16	-10	5/8	16.7	0.66	24.7	0.97	250	3625	500	7250	1000	14500	170	6.69
2SC - 12	19	-12	3/4	19.8	0.78	28.6	1.13	215	3118	430	6235	860	12470	200	7.87
2SC - 16	25	-16	1	26.4	1.04	36.6	1.44	165	2393	330	4786	660	9572	250	9.84

HOSE CONSTRUCTION:

- › Inner Tube: Oil resistant synthetic rubber
- › Reinforcement: Two layers of high tensile steel braid
- › Cover: Oil, abrasion and weather resistant synthetic rubber

MAIN APPLICATIONS: Medium to high pressure lines that require tight bend radius.

TEMPERATURE RANGE:

- › -40°F / +212°F
- › -40°C / +100°C

INTERMITTENT SERVICE:

- › -40°F / +257°F
- › -40°C / +125°C

FULLY MEETS OR EXCEEDS THE FOLLOWING SPECIFICATION(S):

- › EN 857 2SC
- › ISO 11237-1 2SC
- › SAE 100 R16 type S

NOTE: Not all sizes stocked at all times. Some specifications may vary.

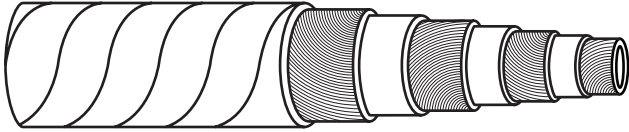

EN856 4SH Multi-Spiral Rubber Hydraulic Hose

4SH SERIES	Hose Size		Hose I.D. (Max)		Hose O.D. (Max)		Working Pressure		Proof Pressure		Burst Pressure		Bend Radius (Min)		
	DN	dash	inch	mm	inch	mm	inch	bar	psi	bar	psi	bar	psi	mm	inch
4SH - 12	19	-12	3/4	19.8	0.78	33.0	1.30	420	6090	840	12180	1680	24360	280	11.02
4SH - 16	25	-16	1	26.4	1.04	39.9	1.57	380	5510	760	11020	1520	22040	340	13.39
4SH - 20	31	-20	1 1/4	33.0	1.30	47.1	1.85	325	4700	650	9400	1296	18800	460	18.11
4SH - 24	38	-24	1 1/2	39.3	1.55	55.1	2.17	290	4200	580	8400	1160	16800	560	22.04
4SH - 32	51	-32	2	52.0	2.05	69.7	2.74	250	3625	500	7250	1000	14500	700	27.56

HOSE CONSTRUCTION:

- › Inner Tube: Oil resistant synthetic rubber
- › Reinforcement: Four spiral wire plies wrapped in alternating directions separated by an insulating layer of synthetic rubber
- › Cover: Oil, abrasion and weather resistant synthetic rubber

MAIN APPLICATIONS: High pressure power/drive lines. Severe abrasion resistance and good resistance to harsh environmental conditions.

TEMPERATURE RANGE:

- › -40°F / +250°F
- › -40°C / +121°C

FULLY MEETS OR EXCEEDS THE FOLLOWING SPECIFICATION(S):

- › EN 856 4SH
- › ISO 3862-1 4SH

NOTE: Not all sizes stocked at all times. Some specifications may vary.

PROPULSE HOSE SOLUTIONS

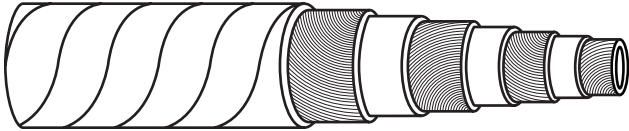

EN856 4SP Multi-Spiral Rubber Hydraulic Hose

4SP SERIES	Hose Size		Hose I.D. (Max)		Hose O.D. (Max)		Working Pressure		Proof Pressure		Burst Pressure		Bend Radius (Min)		
	DN	dash	inch	mm	inch	mm	inch	bar	psi	bar	psi	bar	psi	mm	inch
4SP - 06	10	-06	3/8	10.1	0.40	22.2	0.87	445	6450	890	12900	1780	25806	180	7.09
4SP - 08	12	-08	1/2	13.5	0.53	25.4	1.00	415	6020	830	12035	1660	24070	230	9.06
4SP - 10	16	-10	5/8	16.7	0.66	29.0	1.14	350	5075	700	10150	1400	20300	250	9.84
4SP - 12	19	-12	3/4	19.8	0.78	33.0	1.30	350	5075	700	10150	1400	20300	300	11.81
4SP - 16	25	-16	1	26.4	1.04	40.9	1.61	280	4060	560	8120	1120	16240	340	13.39
4SP - 20	31	-20	1 1/4	33.0	1.30	52.4	2.06	210	3045	420	6090	840	12180	460	18.11

HOSE CONSTRUCTION:

- › Inner Tube: Oil resistant synthetic rubber
- › Reinforcement: Four spiral wire plies wrapped in alternating directions separated by an insulating layer of synthetic rubber
- › Cover: Oil, abrasion and weather resistant synthetic rubber

MAIN APPLICATIONS: High pressure power/drive lines. Severe abrasion resistance and good resistance to harsh environmental conditions.

TEMPERATURE RANGE:

- › -40°F / +250°F
- › -40°C / +121°C

FULLY MEETS OR EXCEEDS THE FOLLOWING SPECIFICATION(S):

- › EN 856 4SP
- › ISO 3862-1 4SP

NOTE: Not all sizes stocked at all times. Some specifications may vary.

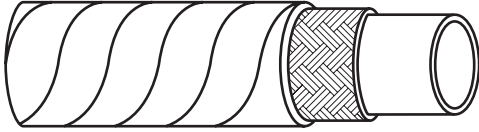

EN854 1TE Rubber Hydraulic Hose

1TE SERIES	Hose Size		Hose I.D. (Max)		Hose O.D. (Max)		Working Pressure		Proof Pressure		Burst Pressure		Bend Radius (Min)		
	DN	dash	inch	mm	inch	mm	inch	bar	psi	bar	psi	bar	psi	mm	inch
1TE - 03	05	-03	3/16	5.2	0.20	11.6	0.46	25	363	50	725	100	1450	35	1.97
1TE - 04	06	-04	1/4	6.9	0.27	13.2	0.52	25	363	50	725	100	1450	45	2.56
1TE - 05	08	-05	5/16	8.4	0.33	14.7	0.58	20	290	40	580	80	1160	65	3.15
1TE - 06	10	-06	3/8	10.0	0.39	16.3	0.64	20	290	40	580	80	1160	75	3.15
1TE - 08	12	-08	1/2	13.3	0.52	19.7	0.76	16	232	32	464	64	928	90	3.94
1TE - 10	16	-10	5/8	16.5	0.65	23.9	0.94	16	232	32	464	64	928	115	4.92

HOSE CONSTRUCTION:

- › Inner Tube: Oil resistant synthetic rubber
- › Reinforcement: High tensile textile cords
- › Cover: Oil, abrasion and weather resistant synthetic rubber

MAIN APPLICATIONS: Low pressure return lines and drain lines.

TEMPERATURE RANGE:

- › -40°F / +212°F
- › -40°C / +100°C

INTERMITTENT SERVICE:

- › -40°F / +257°F
- › -40°C / +125°C

FULLY MEETS OR EXCEEDS THE FOLLOWING SPECIFICATION(S):

- › EN 854 1TE / R6
- › ISO 4079-1 1TE/R6
- › SAE 100R6

NOTE: 1TE and 100R6 hose types are predominately used for low pressure applications, so they are not subjected to impulse test and vacuum resistance test. Not all sizes stocked at all times. Some specifications may vary.

PROPULSE HOSE SOLUTIONS

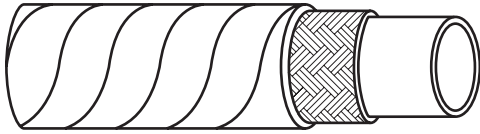

EN854 2TE Rubber Hydraulic Hose

2TE SERIES	Hose Size		Hose I.D. (Max)		Hose O.D. (Max)		Working Pressure		Proof Pressure		Burst Pressure		Bend Radius (Min)		
	DN	dash	inch	mm	inch	mm	inch	bar	psi	bar	psi	bar	psi	mm	inch
	2TE - 03	05	-03	3/16	5.2	0.20	12.6	0.50	80	1160	160	2320	320	4640	35
2TE - 04	06	-04	1/4	6.9	0.27	14.2	0.56	75	1087	150	2174	300	4348	40	1.57
2TE - 05	08	-05	5/16	8.4	0.33	15.7	0.62	68	986	136	1972	272	3944	50	1.97
2TE - 06	10	-06	3/8	10.0	0.39	17.3	0.68	63	913	126	1826	252	3652	60	2.36
2TE - 08	12	-08	1/2	13.3	0.52	20.7	0.81	58	841	116	1682	232	3364	70	2.76
2TE - 10	16	-10	5/8	16.5	0.65	24.9	0.98	50	725	100	1450	200	2900	90	3.54
2TE - 12	19	-12	3/4	19.8	0.78	28.0	1.10	45	652	90	1304	180	2608	110	4.33
2TE - 16	25	-16	1	26.2	1.03	35.9	1.41	40	580	80	1160	160	2320	150	5.91

HOSE CONSTRUCTION:

- › Inner Tube: Oil resistant synthetic rubber
- › Reinforcement: High tensile textile cords
- › Cover: Oil, abrasion and weather resistant synthetic rubber

MAIN APPLICATIONS: Low pressure return lines and drain lines.

TEMPERATURE RANGE:

- › -40°F / +212°F
- › -40°C / +100°C

INTERMITTENT SERVICE:

- › -40°F / +257°F
- › -40°C / +125°C

FULLY MEETS OR EXCEEDS THE FOLLOWING SPECIFICATION(S):

- › EN 854 2TE
- › ISO 4079-1 2TE

NOTE: Not all sizes stocked at all times. Some specifications may vary.

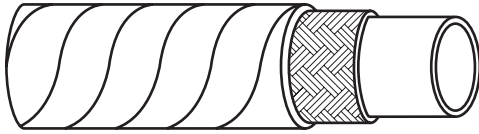

EN854 3TE Rubber Hydraulic Hose

3TE SERIES	Hose Size		Hose I.D. (Max)		Hose O.D. (Max)		Working Pressure		Proof Pressure		Burst Pressure		Bend Radius (Min)		
	DN	dash	inch	mm	inch	mm	inch	bar	psi	bar	psi	bar	psi	mm	inch
3TE - 03	05	-03	3/16	5.2	0.20	13.6	0.54	160	2320	320	4640	640	9280	40	1.57
3TE - 04	06	-04	1/4	6.9	0.27	15.2	0.60	145	2102	290	4204	580	8408	45	1.77
3TE - 05	08	-05	5/16	8.4	0.33	17.7	0.70	130	1885	260	3770	520	7540	55	2.17
3TE - 06	10	-06	3/8	10.0	0.39	19.3	0.76	110	1595	220	3190	440	6380	70	2.76
3TE - 08	12	-08	1/2	13.3	0.52	22.7	0.89	93	1348	186	2696	372	5392	85	3.35
3TE - 10	16	-10	5/8	16.5	0.65	26.9	1.06	80	1160	160	2320	320	4640	105	4.13
3TE - 12	19	-12	3/4	19.8	0.78	30.0	1.18	70	1015	140	2030	280	4060	130	5.12
3TE - 16	25	-16	1	26.2	1.03	37.4	1.47	55	797	110	1594	220	3188	150	5.91

HOSE CONSTRUCTION:

- › Inner Tube: Oil resistant synthetic rubber
- › Reinforcement: High tensile textile cords
- › Cover: Oil, abrasion and weather resistant synthetic rubber

MAIN APPLICATIONS: Low pressure return lines and drain lines.

TEMPERATURE RANGE:

- › -40°F / +212°F
- › -40°C / +100°C

INTERMITTENT SERVICE:

- › -40°F / +257°F
- › -40°C / +125°C

FULLY MEETS OR EXCEEDS THE FOLLOWING SPECIFICATION(S):

- › EN 854 3TE
- › ISO 4079-1 3TE

NOTE: Not all sizes stocked at all times. Some specifications may vary.

PROPULSE HOSE SOLUTIONS

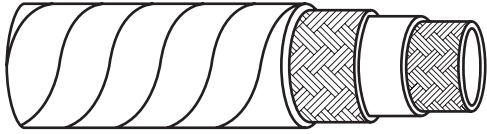

EN857 2SC Arm-A-Flex Rubber Hose

ARM SERIES	Hose Size		Hose I.D. (Max)		Hose O.D. (Max)		Working Pressure		Proof Pressure		Burst Pressure		Bend Radius (Min)		
	DN	dash	inch	mm	inch	mm	inch	bar	psi	bar	psi	bar	psi	mm	inch
Arm - 04	06	-04	1/4	6.9	0.27	14.2	0.55	400	5800	800	11600	1600	23200	75	2.95
Arm - 06	10	-06	3/8	10.1	0.39	18.3	0.72	330	4785	660	9570	1320	19140	90	2.56
Arm - 08	12	-08	1/2	13.5	0.53	21.5	0.84	279	3988	558	8091	1116	16182	130	5.11
Arm - 10	16	-10	5/8	16.7	0.65	24.7	0.97	250	3625	500	7250	1000	14500	170	6.69
Arm - 12	20	-12	3/4	19.8	0.77	28.6	1.12	215	3118	430	6235	860	12470	200	7.87

HOSE CONSTRUCTION:

- › Inner Tube: Oil resistant synthetic rubber
- › Reinforcement: Two layers of high tensile steel braid
- › Cover: Oil, abrasion and weather resistant synthetic rubber manufactured with an additional plastic coating that is highly resistant to abrasion

MAIN APPLICATIONS: Medium to high pressure lines that require tight bend radius. Hose is very resistant to abrasion.

TEMPERATURE RANGE:

- › -40°F / +212°F
- › -40°C / +100°C

INTERMITTENT SERVICE:

- › -40°F / +257°F (may reduce life of this hose)
- › -40°C / +125°C

FULLY MEETS OR EXCEEDS THE FOLLOWING SPECIFICATION(S):

- › EN 857 2SC
- › ISO 11237-1 2SC
- › SAE 100R16 types

NOTE: Not all sizes stocked at all times. Some specifications may vary.

PROPULSE FITTING SOLUTIONS

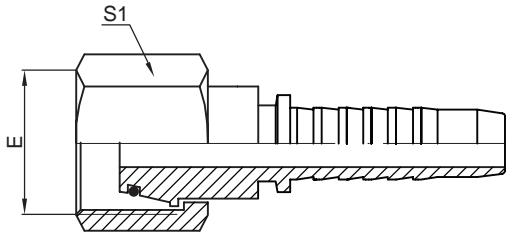

**Metric Female 24° Cone O-Ring DKOL Straight
DIN 20066/3865**

22611 SERIES	Thread	Hose Bore		Dimensions (mm)	
		<i>E</i>	<i>DN</i>	<i>Dash</i>	<i>S1</i>
ProPulse Fitting Part No.					
S22611-10-02	M10X1.0	4	2	12	
S22611-12-02	M12X1.5	4	2	14	
S22611-12-04	M12X1.5	6	4	17	
S22611-14-04	M14X1.5	6	4	17	
S22611-16-04	M16X1.5	6	4	22	
S22611-18-04	M18X1.5	6	4	22	
S22611-14-05	M14X1.5	8	5	17	
S22611-16-05	M16X1.5	8	5	19	
S22611-18-05	M18X1.5	8	5	22	
S22611-22-05	M22X1.5	8	5	27	
S22611-14-06	M14X1.5	10	6	19	
S22611-16-06	M16X1.5	10	6	22	
S22611-18-06	M18X1.5	10	6	22	
S22611-22-06	M22X1.5	10	6	27	
S22611-18-08	M18X1.5	12	8	24	
S22611-22-08	M22X1.5	12	8	27	
S22611-22-10	M22X1.5	16	10	27	
S22611-26-10	M26X1.5	16	10	32	
S22611-30-10	M30X2	16	10	36	
S22611-26-12	M26X1.5	19	12	32	
S22611-30-12	M30X2	19	12	36	
S22611-36-12	M36X2	19	12	41	
S22611-30-16	M30X2	25	16	36	
S22611-36-16	M36X2	25	16	41	
S22611-45-16	M45X2	25	16	50	
S22611-36-20	M36X2	32	20	41	
S22611-45-20	M45X2	32	20	50	
S22611-52-20	M52X2	32	20	60	
S22611-52-24	M52X2	38	24	60	

*Dimensions provided are nominal for reference only and may vary based on current supply.

PROPULSE FITTING SOLUTIONS

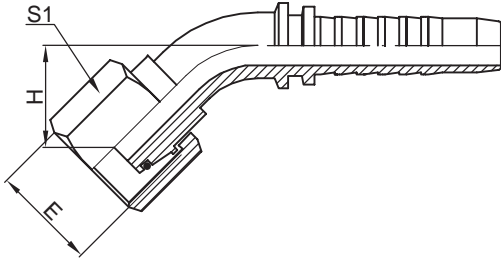

**Metric Female 24° Cone O-Ring DKOL 45° Elbow
DIN 20066/3865**

22641 SERIES	Thread	Hose Bore		Dimensions (mm)		
		<i>E</i>	<i>DN</i>	<i>Dash</i>	<i>S1</i>	<i>H</i>
ProPulse Fitting Part No.						
S22641-14-04	M14X1.5	6	4	19	16	
S22641-16-05	M16X1.5	8	5	19	17	
S22641-18-05	M18X1.5	8	5	22	18.5	
S22641-22-05	M22X1.5	8	5	27	19.5	
S22641-16-06	M16X1.5	10	6	19	17	
S22641-18-06	M18X1.5	10	6	22	18.5	
S22641-22-06	M22X1.5	10	6	27	19.5	
S22641-22-08	M22X1.5	12	8	27	19.5	
S22641-26-08	M26X1.5	12	8	32	23.5	
S22641-26-10	M26X1.5	16	10	32	23.5	
S22641-30-10	M30X2	16	10	36	25.5	
S22641-26-12	M26X1.5	19	12	32	23.5	
S22641-30-12	M30X2	19	12	36	25.5	
S22641-36-12	M36X2	19	12	41	32	
S22641-36-16	M36X2	25	16	41	32	
S22641-45-20	M45X2	32	20	50	38	
S22641-52-20	M52X2	32	20	60	44.5	
S22641-52-24	M52X2	38	24	60	44.5	

*Dimensions provided are nominal for reference only and may vary based on current supply.

PROPULSE FITTING SOLUTIONS

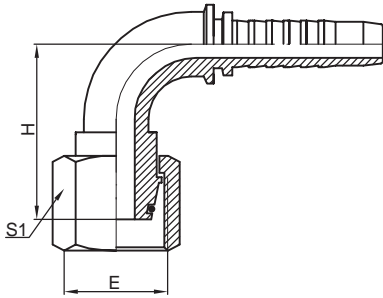

Metric Female 24° Cone O-Ring DKOL 90° Elbow DIN 20066/3865

22691 SERIES	Thread	Hose Bore		Dimensions (mm)	
		<i>DN</i>	<i>Dash</i>	<i>S1</i>	<i>H</i>
ProPulse Fitting Part No.	<i>E</i>				
S22691-12-04	M12X1.5	6	4	14	30
S22691-14-04	M14X1.5	6	4	17	30.5
S22691-16-04	M16X1.5	6	4	22	33
S22691-14-05	M14X1.5	8	5	17	30.5
S22691-16-05	M16X1.5	8	5	19	33
S22691-18-05	M18X1.5	8	5	22	36
S22691-16-06	M16X1.5	10	6	19	36
S22691-18-06	M18X1.5	10	6	22	36
S22691-22-06	M22X1.5	10	6	27	40.5
S22691-22-08	M22X1.5	12	8	27	40.5
S22691-26-08	M26X1.5	12	8	32	51.5
S22691-26-10	M26X1.5	16	10	32	51.5
S22691-30-10	M30X2	16	10	36	56
S22691-26-12	M26X1.5	19	12	32	51.5
S22691-30-12	M30X2	19	12	36	56
S22691-36-12	M36X2	19	12	41	68.5
S22691-30-16	M30X2	25	16	36	56
S22691-36-16	M36X2	25	16	41	68.5
S22691-45-16	M45X2	25	16	50	78.5
S22691-36-20	M36X2	32	20	41	68.5
S22691-45-20	M45X2	32	20	50	78.5
S22691-52-20	M52X2	32	20	60	95
S22691-52-24	M52X2	38	24	60	95

*Dimensions provided are nominal for reference only and may vary based on current supply.

PROPULSE FITTING SOLUTIONS

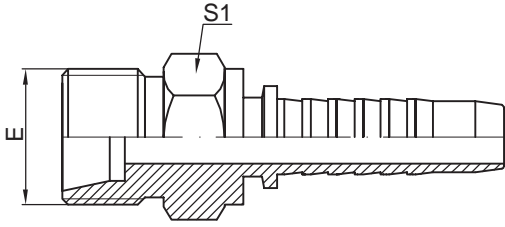

**Metric Male 24° Cone Seat DKOL Straight
DIN 20066/3861**

12611 SERIES	Thread	Hose Bore		Dimensions (mm)	
		<i>E</i>	<i>DN</i>	<i>Dash</i>	<i>S1</i>
ProPulse Fitting Part No.					
S12611-12-04	M12X1.5	6	4	14	
S12611-14-04	M14X1.5	6	4	17	
S12611-16-04	M16X1.5	6	4	17	
S12611-14-05	M14X1.5	8	5	17	
S12611-16-05	M16X1.5	8	5	17	
S12611-18-05	M18X1.5	8	5	19	
S12611-16-06	M16X1.5	10	6	17	
S12611-18-06	M18X1.5	10	6	19	
S12611-22-06	M22X1.5	10	6	24	
S12611-22-08	M22X1.5	12	8	24	
S12611-26-08	M26X1.5	12	8	27	
S12611-22-10	M22X1.5	16	10	22	
S12611-26-10	M26X1.5	16	10	27	
S12611-30-10	M30X2	16	10	32	
S12611-30-12	M30X2	19	12	32	
S12611-36-16	M36X2	25	16	41	
S12611-45-20	M45X2	32	20	46	
S12611-52-24	M52X2	38	24	55	

*Dimensions provided are nominal for reference only and may vary based on current supply.

PROPULSE FITTING SOLUTIONS

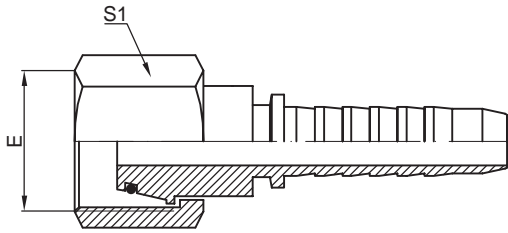

**Metric Female 24° Cone O-Ring DKOS Straight
DIN 20066/3865**

22711 SERIES	Thread	Hose Bore		Dimensions (mm)	
		<i>E</i>	<i>DN</i>	<i>Dash</i>	<i>S1</i>
ProPulse Fitting Part No.					
S22711-14-04	M14X1.5	6	4	19	
S22711-16-04	M16X1.5	6	4	19	
S22711-18-04	M18X1.5	6	4	22	
S22711-16-05	M16X1.5	8	5	19	
S22711-20-05	M20X1.5	8	5	24	
S22711-18-06	M18X1.5	10	6	22	
S22711-20-06	M20X1.5	10	6	24	
S22711-22-06	M22X1.5	10	6	27	
S22711-24-06	M24X1.5	10	6	30	
S22711-20-08	M20X1.5	12	8	24	
S22711-22-08	M22X1.5	12	8	27	
S22711-24-08	M24X1.5	12	8	30	
S22711-30-10	M30X2	16	10	36	
S22711-30-12	M30X2	19	12	36	
S22711-36-12	M36X2	19	12	46	
S22711-42-12	M42X2	19	12	50	
S22711-36-16	M36X2	25	16	46	
S22711-42-16	M42X2	25	16	50	
S22711-52-20	M52X2	32	20	60	
S22711-52-24	M52X2	38	24	60	

*Dimensions provided are nominal for reference only and may vary based on current supply.

PROPULSE FITTING SOLUTIONS

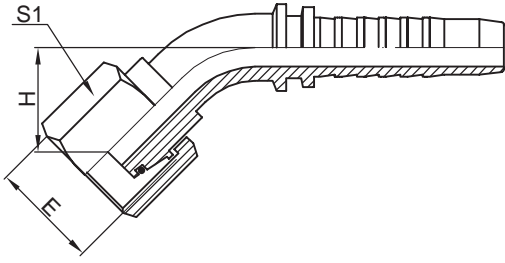

**Metric Female 24° Cone O-Ring DKOS 45° Elbow
DIN 20066/3865**

22741 SERIES	Thread	Hose Bore		Dimensions (mm)	
		DN	Dash	S1	H
ProPulse Fitting Part No.	E				
S22741-14-04	M14X1.5	6	4	19	17
S22741-16-04	M16X1.5	6	4	19	17
S22741-18-04	M18X1.5	6	4	22	17
S22741-16-05	M16X1.5	8	5	19	17
S22741-18-06	M18X1.5	10	6	22	17
S22741-20-06	M20X1.5	10	6	24	18
S22741-22-06	M22X1.5	10	6	27	21
S22741-20-08	M20X1.5	12	8	24	18.5
S22741-22-08	M22X1.5	12	8	27	21
S22741-24-08	M24X1.5	12	8	30	21
S22741-24-10	M24X1.5	16	10	30	21
S22741-30-10	M30X2	16	10	36	25
S22741-30-12	M30X2	19	12	36	25
S22741-36-12	M36X2	19	12	46	30.5
S22741-42-16	M42X2	25	16	50	35.5
S22741-52-20	M52X2	32	20	60	42
S22741-52-25	M52X2	38	24	60	42

*Dimensions provided are nominal for reference only and may vary based on current supply.

PROPULSE FITTING SOLUTIONS

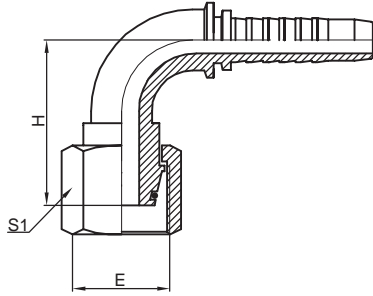

**Metric Female 24° Cone O-Ring DKOS 90° Elbow
DIN 20066/3865**

22791 SERIES	Thread	Hose Bore		Dimensions (mm)	
		DN	Dash	S1	H
ProPulse Fitting Part No.	E				
S22791-14-04	M14X1.5	6	4	19	32
S22791-16-04	M16X1.5	6	4	19	32
S22791-18-04	M18X1.5	6	4	22	32
S22791-16-05	M16X1.5	8	5	19	32
S22791-18-05	M18X1.5	8	5	22	32
S22791-20-05	M20X1.5	8	5	24	34
S22791-18-06	M18X1.5	10	6	22	32
S22791-20-06	M20X1.5	10	6	24	35.5
S22791-22-06	M22X1.5	10	6	27	35.5
S22791-20-08	M20X1.5	12	8	24	35.5
S22791-22-08	M22X1.5	12	8	27	35.5
S22791-24-08	M24X1.5	12	8	30	43
S22791-30-08	M30X2	12	8	36	49.5
S22791-24-10	M24X1.5	16	10	30	43
S22791-30-10	M30X2	16	10	36	49.5
S22791-30-12	M30X2	19	12	36	49.5
S22791-36-12	M36X2	19	12	46	59
S22791-42-16	M42X2	25	16	50	70
S22791-52-20	M52X2	32	20	60	87
S22791-52-24	M52X2	38	24	60	87

*Dimensions provided are nominal for reference only and may vary based on current supply.

PROPULSE FITTING SOLUTIONS

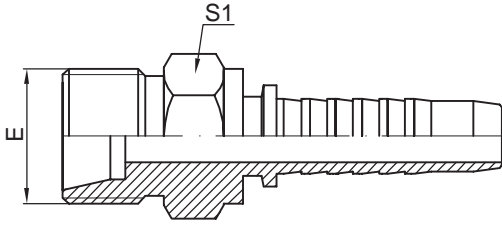

**Metric Male 24° Cone Seat DKOS Straight
DIN 20066/3861**

12711 SERIES	Thread	Hose Bore		Dimensions (mm)	
		<i>E</i>	<i>DN</i>	<i>Dash</i>	<i>S1</i>
ProPulse Fitting Part No.					
S12711-14-04	M14X1.5	6	4	17	
S12711-16-04	M16X1.5	6	4	17	
S12711-18-04	M18X1.5	6	4	19	
S12711-20-05	M20X1.5	8	5	22	
S12711-22-05	M22X1.5	8	5	24	
S12711-20-06	M20X1.5	10	6	22	
S12711-22-06	M22X1.5	10	6	24	
S12711-22-08	M22X1.5	12	8	24	
S12711-24-08	M24X1.5	12	8	27	
S12711-30-10	M30X2	16	10	32	
S12711-36-12	M36X2	19	12	41	
S12711-36-16	M36X2	25	16	41	
S12711-42-16	M42X2	25	16	46	
S12711-42-20	M42X2	32	20	46	
S12711-52-20	M52X2	32	20	55	

*Dimensions provided are nominal for reference only and may vary based on current supply.

PROPULSE FITTING SOLUTIONS

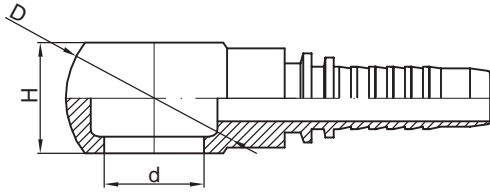

**Metric Banjo
DIN 7642**

72211 SERIES	Thread	Hose Bore		Dimensions (mm)		
		<i>DN</i>	<i>Dash</i>	<i>d</i>	<i>D</i>	<i>H</i>
ProPulse Fitting Part No.	<i>E</i>					
S72211-10-03	M10X1	5	3	10.1	17	10
S72211-10-04	M10X1	6	4	10.1	17	10
S72211-12-04	M12X1.5	6	4	12.1	20	12
S72211-14-04	M14X1.5	6	4	14.1	24	14
S72211-16-04	M16X1.5	6	4	16.1	28	16
S72211-18-04	M18X1.5	6	4	18.1	32	20
S72211-12-05	M12X1.5	8	5	12.1	20	12
S72211-14-05	M14X1.5	8	5	14.1	24	14
S72211-16-05	M16X1.5	8	5	16.1	28	16
S72211-18-05	M18X1.5	8	5	18.1	32	20
S72211-12-06	M12X1.5	10	6	12.1	20	12
S72211-14-06	M14X1.5	10	6	14.1	24	14
S72211-16-06	M16X1.5	10	6	16.1	28	16
S72211-18-06	M18X1.5	10	6	18.1	32	20
S72211-22-06	M22X1.5	10	6	22.1	39	25
S72211-18-08	M18X1.5	12	8	18.1	32	20
S72211-22-08	M22X1.5	12	8	22.1	39	25
S72211-22-10	M22X1.5	16	10	22.1	39	25
S72211-26-12	M26X1.5	19	12	26.1	46	30
S72211-30-16	M30X1.5	25	16	30.1	54	36
S72211-30-20	M30X1.5	32	20	30.1	54	36

*Dimensions provided are nominal for reference only and may vary based on current supply.

PROPULSE FITTING SOLUTIONS

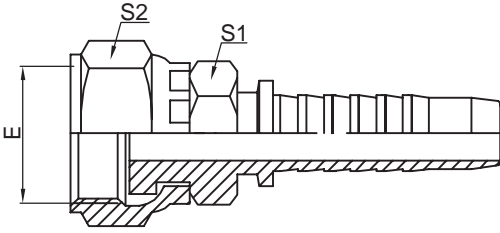

**ORFS Female Short Straight
SAE J1453/J516**

26411S SERIES	Thread	Hose Bore		Dimensions (mm)		
		<i>E</i>	<i>DN</i>	<i>Dash</i>	<i>S1</i>	<i>S2</i>
ProPulse Fitting Part No.						
S26411S-04-04	9/16"X18	6	4	13	17	
S26411S-06-04	11/16"X16	6	4	17	22	
S26411S-04-05	9/16"X18	8	5	17	19	
S26411S-06-05	11/16"X16	8	5	17	22	
S26411S-08-05	13/16"X16	8	5	19	24	
S26411S-04-06	9/16"X18	10	6	13	17	
S26411S-06-06	11/16"X16	10	6	17	22	
S26411S-08-06	13/16"X16	10	6	22	24	
S26411S-06-08	11/16"X16	12	8	17	22	
S26411S-08-08	13/16"X16	12	8	22	24	
S26411S-10-08	1"X14	12	8	24	30	
S26411S-12-08	1.3/16"X12	12	8	28	36	
S26411S-08-10	13/16"X16	16	10	22	24	
S26411S-10-10	1"X14	16	10	24	30	
S26411S-12-10	1.3/16"X12	16	10	28	36	
S26411S-10-12	1"X14	19	12	24	30	
S26411S-12-12	1.3/16"X12	19	12	28	36	
S26411S-16-12	1.7/16"X12	19	12	36	41	
S26411S-12-16	1.3/16"X12	25	16	28	36	
S26411S-16-16	1.7/16"X12	25	16	36	41	
S26411S-20-16	1.11/16"X12	25	16	41	50	
S26411S-16-20	1.7/16"X12	32	20	36	41	
S26411S-20-20	1.11/16"X12	32	20	41	50	
S26411S-24-20	2"X12	32	20	50	60	
S26411S-20-24	1.11/16"X12	38	24	41	50	
S26411S-24-24	2"X12	38	24	50	60	

*Dimensions provided are nominal for reference only and may vary based on current supply.

PROPULSE FITTING SOLUTIONS

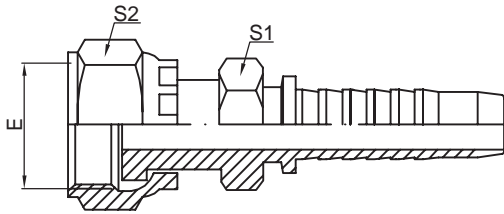

**ORFS Female Long Straight
SAE J1453/J516**

26411L SERIES	Thread	Hose Bore		Dimensions (mm)		
		<i>E</i>	<i>DN</i>	<i>Dash</i>	<i>S1</i>	<i>S2</i>
ProPulse Fitting Part No.						
S26411L-04-04	9/16"X18	6	4	13	19	
S26411L-06-04	11/16"X16	6	4	17	22	
S26411L-04-05	9/16"X18	8	5	13	17	
S26411L-06-05	11/16"X16	8	5	17	22	
S26411L-06-06	11/16"X16	10	6	17	22	
S26411L-08-06	13/16"X16	10	6	19	27	
S26411L-06-08	11/16"X16	12	8	19	22	
S26411L-08-08	13/16"X16	12	8	22	24	
S26411L-10-08	1"X14	12	8	24	30	
S26411L-12-08	1.3/16"X12	12	8	28	36	
S26411L-10-10	1"X14	16	10	24	30	
S26411L-12-10	1.3/16"X12	16	10	28	36	
S26411L-10-12	1"X14	19	12	28	30	
S26411L-12-12	1.3/16"X12	19	12	28	36	
S26411L-16-12	1.7/16"X12	19	12	36	41	
S26411L-12-16	1.3/16"X12	25	16	28	36	
S26411L-16-16	1.7/16"X12	25	16	36	41	
S26411L-20-16	1.11/16"X12	25	16	41	50	
S26411L-20-20	1.11/16"X12	32	20	41	50	
S26411L-24-24	2"X12	38	24	50	60	
S26411S-20-16	1.11/16"X12	25	16	41	50	
S26411S-16-20	1.7/16"X12	32	20	36	41	
S26411S-20-20	1.11/16"X12	32	20	41	50	
S26411S-24-20	2"X12	32	20	50	60	
S26411S-20-24	1.11/16"X12	38	24	41	50	
S26411S-24-24	2"X12	38	24	50	60	

*Dimensions provided are nominal for reference only and may vary based on current supply.

PROPULSE FITTING SOLUTIONS

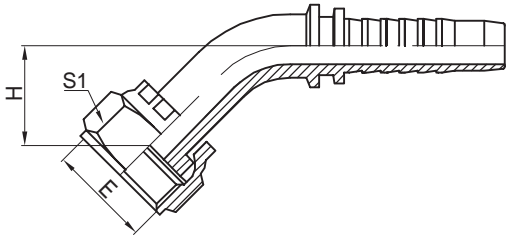

**ORFS Female 45° Elbow
SAE J1453/J516**

26441 SERIES	Thread	Hose Bore	Dimensions (mm)	
			S1	H
ProPulse Fitting Part No.	E	DN	S1	H
S26441-04-04	9/16"X18	6	19	10
S26441-06-04	11/16"X16	6	22	11
S26441-04-05	9/16"X18	8	19	10
S26441-06-05	11/16"X16	8	22	11
S26441-04-06	9/16"X18	10	19	10
S26441-06-06	11/16"X16	10	22	11
S26441-08-06	13/16"X16	10	24	15
S26441-06-08	11/16"X16	12	22	11
S26441-08-08	13/16"X16	12	24	15
S26441-10-08	1"X14	12	30	16
S26441-12-08	1.3"/16X12	12	36	21
S26441-08-10	13/16"X16	16	24	15
S26441-10-10	1"X14	16	30	16
S26441-12-10	1.3/16"X12	16	36	21
S26441-10-12	1"X14	19	30	16
S26441-12-12	1.3/16"X12	19	36	21
S26441-16-12	1.7/16"X12	19	41	24
S26441-12-16	1.3/16"X12	25	36	21
S26441-16-16	1.7/16"X12	25	41	24
S26441-20-16	1.11/16"X12	25	50	25
S26441-16-20	1.7/16"X12	32	41	24
S26441-20-20	1.11/16"X12	32	50	25
S26441-24-20	2"X12	32	60	27
S26441-20-24	1.11/16"X12	38	50	25
S26441-24-24	2"X12	38	60	27

*Dimensions provided are nominal for reference only and may vary based on current supply.

PROPULSE FITTING SOLUTIONS

ORFS Female 90° Elbow SAE J1453/J516

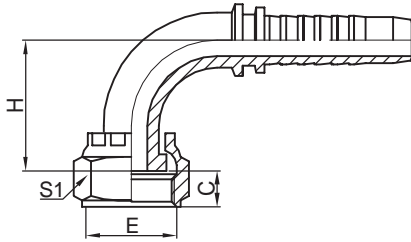

26491 SERIES	Thread	Hose Bore		Dimensions (mm)	
		<i>DN</i>	<i>Dash</i>	<i>S1</i>	<i>H</i>
ProPulse Fitting Part No.	<i>E</i>				
S26491-04-04	9/16"X18	6	4	19	21
S26491-06-04	11/16"X16	6	4	22	23
S26491-04-05	9/16"X18	8	5	19	21
S26491-06-05	11/16"X16	8	5	22	23
S26491-04-06	9/16"X18	10	6	19	21
S26491-06-06	11/16"X16	10	6	22	23
S26491-08-06	13/16"X16	10	6	24	29
S26491-06-08	11/16"X16	12	8	22	23
S26491-08-08	13/16"X16	12	8	24	29
S26491-10-08	1"X14	12	8	30	32
S26491-08-10	13/16"X16	16	10	24	29
S26491-10-10	1"X14	16	10	30	32
S26491-12-10	1.3/16"X12	16	10	36	48
S26491-10-12	1"X14	19	12	30	32
S26491-12-12	1.3/16"X12	19	12	36	48
S26491-16-12	1.7/16"X12	19	12	41	56
S26491-12-16	1.3/16"X12	25	16	36	48
S26491-16-16	1.7/16"X12	25	16	41	56
S26491-20-16	1.11/16"X12	25	16	50	64
S26491-16-20	1.7/16"X12	32	20	41	56
S26491-20-20	1.11/16"X12	32	20	50	64
S26491-24-20	2"X12	32	20	60	69
S26491-20-24	1.11/16"X12	38	24	50	64
S26491-24-24	2"X12	38	24	60	69

*Dimensions provided are nominal for reference only and may vary based on current supply.

PROPULSE FITTING SOLUTIONS

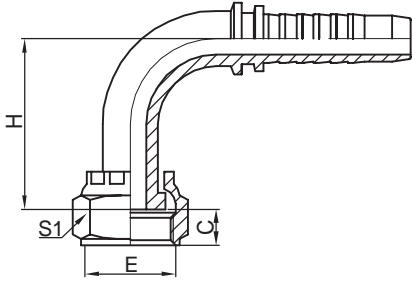

**ORFS Female 90° Elbow Medium Drop
SAE J1453/J516**

26491M SERIES	Thread	Hose Bore		Dimensions (mm)		
		<i>E</i>	<i>DN</i>	<i>Dash</i>	<i>S1</i>	<i>H</i>
ProPulse Fitting Part No.						
S26491M-04-04	9/16"X18	6	4	19	32	
S26491M-06-04	11/16"X16	6	4	22	38	
S26491M-06-06	11/16"X16	10	6	22	38	
S26491M-08-06	13/16"X16	10	6	24	41	
S26491M-08-08	13/16"X16	12	8	24	41	
S26491M-10-08	1"X14	12	8	30	47	
S26491M-10-10	1"X14	16	10	30	47	
S26491M-10-12	1"X14	19	12	30	47	
S26491M-12-12	1.3/16"X12	19	12	36	58	
S26491M-16-16	1.7/16"X12	25	16	41	71	
S26491M-20-20	1.11/16"X12	32	20	50	78	
S26491M-24-24	2"X12	38	24	60	86	

*Dimensions provided are nominal for reference only and may vary based on current supply.

PROPULSE FITTING SOLUTIONS

ORFS Female 90° Elbow Long Drop SAE J1453/J516

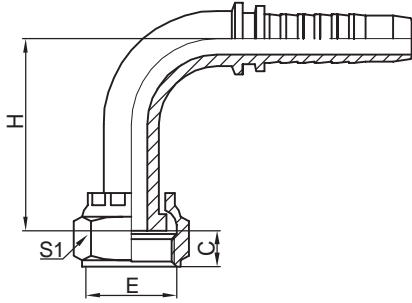

26491L SERIES	Thread	Hose Bore		Dimensions (mm)	
		<i>DN</i>	<i>Dash</i>	<i>S1</i>	<i>H</i>
ProPulse Fitting Part No.	<i>E</i>				
S26491L-04-04	9/16"X18	6	4	17	46
S26491L-06-06	11/16"X16	10	6	22	54
S26491L-08-06	13/16"X16	10	6	24	64
S26491L-08-08	13/16"X16	12	8	24	64
S26491L-10-08	1"X14	12	8	30	70
S26491L-10-10	1"X14	16	10	30	70
S26491L-10-12	1"X14	19	12	30	70
S26491L-12-12	1.3/16"X12	19	12	36	96
S26491L-16-16	1.7/16"X12	25	16	41	114
S26491L-20-20	1.11/16"X12	31	20	50	129
S26491L-24-24	2"X12	38	24	60	141

*Dimensions provided are nominal for reference only and may vary based on current supply.

PROPULSE FITTING SOLUTIONS

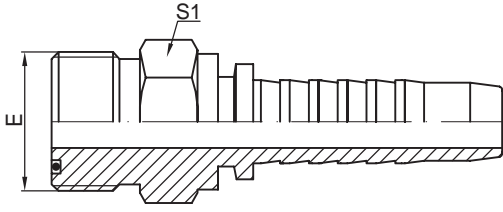

**ORFS Male Straight
SAE J1453/J516**

16411 SERIES	Thread	Hose Bore		Dimensions (mm)	
		<i>E</i>	<i>Dn</i>	<i>Dash</i>	<i>S1</i>
ProPulse Fitting Part No.					
S16411-04-04	9/16"X18	6	4	17	
S16411-06-04	11/16"X16	6	4	19	
S16411-06-06	11/16"X16	10	6	19	
S16411-08-06	13/16"X16	10	6	22	
S16411-08-08	13/16"X16	12	8	22	
S16411-10-08	1"X14	12	8	27	
S16411-12-08	1.3/16"X12	12	8	32	
S16411-08-10	13/16"X16	16	10	22	
S16411-10-10	1"X14	16	10	27	
S16411-12-10	1.3/16"X12	16	10	32	
S16411-12-12	1.3/16"X12	19	12	32	
S16411-16-12	1.7/16"X12	19	12	41	
S16411-16-16	1.7/16"X12	25	16	41	
S16411-20-20	1.11/16"X12	32	20	46	
S16411-24-24	2"X12	38	24	55	

*Dimensions provided are nominal for reference only and may vary based on current supply.

PROPULSE FITTING SOLUTIONS

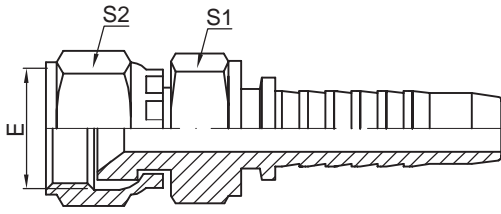

JIC Female 37° Cone Double Hex Straight SAE J514/J516

28911D SERIES	Thread	Hose Bore		Dimensions (mm)		
		<i>E</i>	<i>DN</i>	<i>Dash</i>	<i>S1</i>	<i>S2</i>
ProPulse Fitting Part No.						
S28911D-03-04	7/16"X20	6	4	16	14	
S28911D-04-03	7/16"X20	5	3	17	17	
S28911D-04-04	7/16"X20	6	4	17	17	
S28911D-05-04	1/2"X20	6	4	17	17	
S28911D-06-04	9/16"X18	6	4	19	19	
S28911D-05-05	1/2"X20	8	5	17	17	
S28911D-06-05	9/16"X18	8	5	17	19	
S28911D-08-05	3/4"X16	8	5	19	24	
S28911D-04-06	7/16"X20	10	6	17	17	
S28911D-05-06	1/2"X20	10	6	17	17	
S28911D-06-06	9/16"X18	10	6	19	19	
S28911D-08-06	3/4"X16	10	6	19	24	
S28911D-10-06	7/8"X14	10	6	22	27	
S28911D-06-08	9/16"X18	12	8	19	19	
S28911D-08-08	3/4"X16	12	8	22	24	
S28911D-10-08	7/8"X14	12	8	22	27	
S28911D-12-08	1.1/16"X12	12	8	27	32	
S28911D-08-10	3/4"X16	16	10	24	24	
S28911D-10-10	7/8"X14	16	10	24	27	
S28911D-12-10	1.1/16"X12	16	10	27	32	
S28911D-08-12	3/4"X16	19	12	24	24	
S28911D-10-12	7/8"X14	19	12	27	27	
S28911D-12-12	1.1/16"X12	19	12	27	32	
S28911D-16-12	1.5/16"X12	19	12	32	41	
S28911D-12-16	1.1/16"X12	25	16	32	32	
S28911D-16-16	1.5/16"X12	25	16	41	41	
S28911D-20-16	1.5/8"X12	25	16	41	50	
S28911D-20-20	1.5/8"X12	32	20	50	50	
S28911D-24-24	1.7/8"X12	38	24	60	60	
S28911D-32-32	2.1/2"X12	50	32	75	75	

*Dimensions provided are nominal for reference only and may vary based on current supply.

PROPULSE FITTING SOLUTIONS

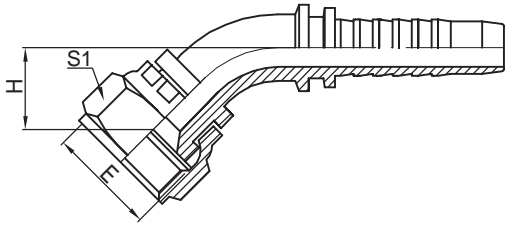

**JIC Female 37° Cone 45° Elbow
SAE J514/J516**

28941 SERIES	Thread	Hose Bore		Dimensions (mm)		
		<i>E</i>	<i>DN</i>	<i>Dash</i>	<i>S1</i>	<i>H</i>
ProPulse Fitting Part No.						
S28941-04-03	7/16"X20	5	3	17	10	
S28941-04-04	7/16"X20	6	4	17	10	
S28941-05-04	1/2"X20	6	4	17	10	
S28941-06-04	9/16"X18	6	4	19	11	
S28941-05-05	1/2"X20	8	5	17	10	
S28941-06-05	9/16"X18	8	5	19	11	
S28941-05-06	1/2"X20	10	6	17	10	
S28941-06-06	9/16"X18	10	6	19	11	
S28941-08-06	3/4"X16	10	6	24	15	
S28941-06-08	9/16"X18	12	8	19	11	
S28941-08-08	3/4"X16	12	8	24	15	
S28941-10-08	7/8"X14	12	8	27	16	
S28941-12-08	1.1/16"X12	12	8	32	21	
S28941-10-10	7/8"X14	16	10	27	16	
S28941-12-10	1.1/16"X12	16	10	32	21	
S28941-10-12	7/8"X14	19	12	27	16	
S28941-12-12	1.1/16"X12	19	12	32	21	
S28941-14-12	1.3/16"X12	19	12	36	21	
S28941-16-12	1.5/16"X12	19	12	41	24	
S28941-12-16	1.1/16"X12	25	16	32	21	
S28941-16-16	1.5/16"X12	25	16	41	24	
S28941-16-20	1.5/16"X12	32	20	41	24	
S28941-20-20	1.5/8"X12	32	20	50	25	
S28941-24-20	1.7/8"X12	32	20	60	27	
S28941-24-24	1.7/8"X12	38	24	60	27	
S28941-32-32	2.1/2"X12	50	32	75	34	

*Dimensions provided are nominal for reference only and may vary based on current supply.

PROPULSE FITTING SOLUTIONS

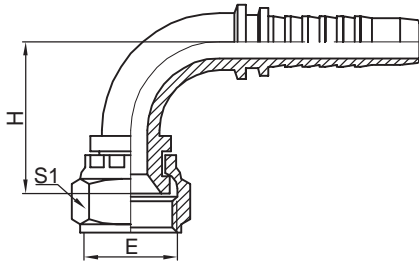

**JIC Female 37° Cone 90° Elbow
SAE J514/J516**

28991 SERIES	Thread	Hose Bore		Dimensions (mm)	
		<i>DN</i>	<i>Dash</i>	<i>S1</i>	<i>H</i>
ProPulse Fitting Part No.	<i>E</i>				
S28991-04-04	7/16"X20	6	4	17	21
S28991-05-04	1/2"X20	6	4	17	21
S28991-06-04	9/16"X18	6	4	19	23
S28991-05-05	1/2"X20	8	5	17	21
S28991-06-05	9/16"X18	8	5	19	23
S28991-05-06	1/2"X20	10	6	17	21
S28991-06-06	9/16"X18	10	6	19	23
S28991-08-06	3/4"X16	10	6	24	29
S28991-06-08	9/16"X18	12	8	19	23
S28991-08-08	3/4"X16	12	8	24	29
S28991-10-08	7/8"X14	12	8	27	32
S28991-12-08	1.1/16"X12	12	8	32	48
S28991-08-10	3/4"X16	16	10	24	29
S28991-10-10	7/8"X14	16	10	27	32
S28991-12-10	1.1/16"X12	16	10	32	48
S28991-10-12	7/8"X14	19	12	27	32
S28991-12-12	1.1/16"X12	19	12	32	48
S28991-14-12	1.3/16"X12	19	12	36	51
S28991-16-12	1.5/16"X12	19	12	41	56
S28991-12-16	1.1/16"X12	25	16	32	48
S28991-16-16	1.5/16"X12	25	16	41	56
S28991-20-16	1.5/8"X12	25	16	50	60
S28991-16-20	1.5/16"X12	32	20	41	56
S28991-20-20	1.5/8"X12	32	20	50	64
S28991-24-20	1.7/8"X12	32	20	60	69
S28991-24-24	1.7/8"X12	38	24	60	69
S28991-32-32	2.1/2"X12	50	32	75	88

*Dimensions provided are nominal for reference only and may vary based on current supply.

PROPULSE FITTING SOLUTIONS

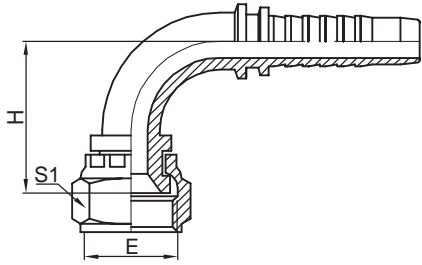

**JIC Female 37° Cone 90° Elbow Medium Drop
SAE J514/J516**

28991M SERIES	Thread	Hose Bore		Dimensions (mm)	
		<i>DN</i>	<i>Dash</i>	<i>S1</i>	<i>H</i>
ProPulse Fitting Part No.	<i>E</i>				
S28991M-04-04	7/16"X20	6	4	17	32
S28991M-06-06	9/16"X18	10	6	19	38
S28991M-08-06	3/4"X16	10	6	24	41
S28991M-08-08	3/4"X16	12	8	24	41
S28991M-12-10	1.1/16"X12	16	10	32	58
S28991M-12-12	1.1/16"X12	19	12	32	58

*Dimensions provided are nominal for reference only and may vary based on current supply.

PROPULSE FITTING SOLUTIONS

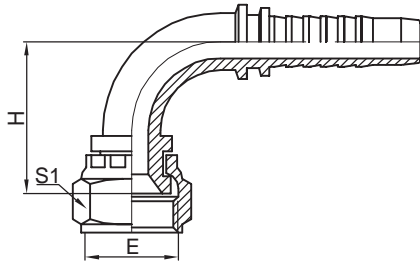

**JIC Female 37° Cone 90° Elbow Long Drop
SAE J514/J516**

28991L SERIES	Thread	Hose Bore		Dimensions (mm)	
		<i>DN</i>	<i>Dash</i>	<i>S1</i>	<i>H</i>
ProPulse Fitting Part No.	<i>E</i>				
S28991L-04-04	7/16"X20	6	4	17	46
S28991L-05-04	1/2"X20	6	4	17	46
S28991L-06-06	9/16"X18	10	6	19	54
S28991L-08-06	3/4"X16	10	6	24	64
S28991L-08-08	3/4"X16	12	8	24	64
S28991L-10-10	7/8"X14	16	10	27	70
S28991L-12-12	1.1/16"X12	19	12	32	93
S28991L-14-12	1.3/16"X12	19	12	36	100
S28991L-16-16	1.5/16"X12	25	16	41	114
S28991L-20-20	1.5/8"X12	32	20	50	129
S28991L-24-24	1.7/8"X12	38	24	60	141
S28991L-32-32	2.1/2"X12	50	32	75	222

*Dimensions provided are nominal for reference only and may vary based on current supply.

PROPULSE FITTING SOLUTIONS

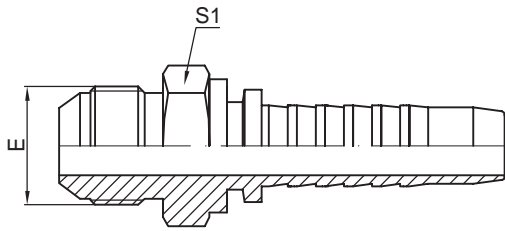

**JJIC Male 37° Cone Straight
SAE J514/J516**

18911 SERIES	Thread	Hose Bore		Dimensions (mm)	
		<i>E</i>	<i>DN</i>	<i>Dash</i>	<i>S1</i>
ProPulse Fitting Part No.					
S18911-04-03	7/16"X20	5	3	14	
S18911-04-04	7/16"X20	6	4	14	
S18911-05-04	1/2"X20	6	4	14	
S18911-06-04	9/16"X18	6	4	17	
S18911-05-05	1/2"X20	8	5	14	
S18911-06-05	9/16"X18	8	5	17	
S18911-05-06	1/2"X20	10	6	17	
S18911-06-06	9/16"X18	10	6	17	
S18911-08-06	3/4"X16	10	6	22	
S18911-10-06	7/8"X14	10	6	24	
S18911-08-08	3/4"X16	12	8	22	
S18911-10-08	7/8"X14	12	8	24	
S18911-12-08	1.1/16"X12	12	8	27	
S18911-10-10	7/8"X14	16	10	24	
S18911-12-10	1.1/16"X12	16	10	27	
S18911-14-10	1.3/16"X12	16	10	32	
S18911-12-12	1.1/16"X12	19	12	27	
S18911-14-12	1.3/16"X12	19	12	32	
S18911-16-12	1.5/16"X12	19	12	36	
S18911-12-16	1.1/16"X12	25	16	27	
S18911-16-16	1.5/16"X12	25	16	36	
S18911-20-16	1.5/8"X12	25	16	46	
S18911-20-20	1.5/8"X12	32	20	46	
S18911-24-20	1.7/8"X12	32	20	50	
S18911-24-24	1.7/8"X12	38	24	50	
S18911-32-32	2.1/2"X12	50	32	65	

*Dimensions provided are nominal for reference only and may vary based on current supply.

PROPULSE FITTING SOLUTIONS

**NPTF Male 30° Cone Straight
SAE J516**

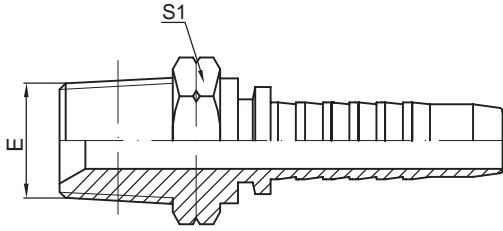

17811 SERIES	Thread	Hose Bore		Dimensions (mm)	
		<i>E</i>	<i>DN</i>	<i>Dash</i>	<i>S1</i>
ProPulse Fitting Part No.					
S17811-02-03	1/8"X27	5	3	14	
S17811-04-03	1/4"X18	5	3	14	
S17811-02-04	1/8"X27	6	4	14	
S17811-04-04	1/4"X18	6	4	14	
S17811-06-04	3/8"X18	6	4	19	
S17811-08-04	1/2"X14	6	4	22	
S17811-04-05	1/4"X18	8	5	17	
S17811-06-05	3/8"X18	8	5	19	
S17811-04-06	1/4"X18	10	6	17	
S17811-06-06	3/8"X18	10	6	19	
S17811-08-06	1/2"X14	10	6	22	
S17811-06-08	3/8"X18	12	8	22	
S17811-08-08	1/2"X14	12	8	22	
S17811-12-08	3/4"X14	12	8	27	
S17811-08-10	1/2"X14	16	10	22	
S17811-12-10	3/4"X14	16	10	27	
S17811-16-10	1"X11.5	16	10	36	
S17811-12-12	3/4"X14	19	12	27	
S17811-16-12	1"X11.5	19	12	36	
S17811-12-16	3/4"X14	25	16	27	
S17811-16-16	1"X11.5	25	16	36	
S17811-20-16	1.1/4"X11.5	25	16	46	
S17811-20-20	1.1/4"X11.5	32	20	46	
S17811-24-24	1.1/2"X11.5	38	24	50	
S17811-32-32	2"X11.5	50	32	65	

*Dimensions provided are nominal for reference only and may vary based on current supply.

PROPULSE FITTING SOLUTIONS

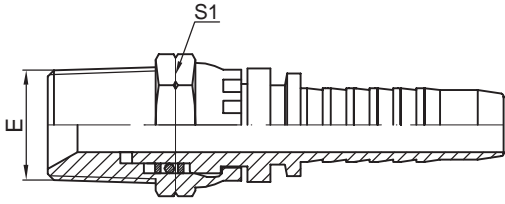

**NPTF Swivel Male 30° Cone Straight
SAE J516**

17811W SERIES	Thread	Hose Bore		Dimensions (mm)	
		DN	Dash	S1	
ProPulse Fitting Part No.	E				
S17811W-02-04	1/8"X27	6	4	14	
S17811W-04-04	1/4"X18	6	4	17	
S17811W-06-04	3/8"X18	6	4	19	
S17811W-06-05	3/8"X18	8	5	19	
S17811W-04-06	1/4"X18	10	6	17	
S17811W-06-06	3/8"X18	10	6	19	
S17811W-08-06	1/2"X14	10	6	22	
S17811W-08-08	1/2"X14	12	8	22	
S17811W-12-12	3/4"X14	19	12	27	
S17811W-16-16	1"X11.5	25	16	36	

*Dimensions provided are nominal for reference only and may vary based on current supply.

NPT Female Solid Straight

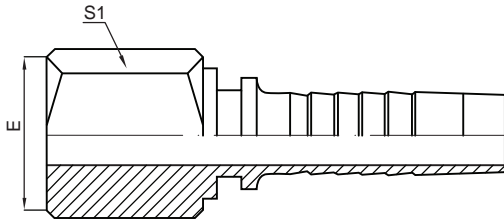

27811 SERIES	Thread	Hose Bore		Dimensions (mm)	
		<i>DN</i>	<i>Dash</i>	<i>S1</i>	
ProPulse Fitting Part No.	<i>E</i>				
S27811-04-04	1/4"X18	6	4	19	
S27811-04-06	1/4"X18	10	6	19	
S27811-06-06	3/8"18	10	6	22	
S27811-08-06	1/2"X14	10	6	25.4	

*Dimensions provided are nominal for reference only and may vary based on current supply.

PROPULSE FITTING SOLUTIONS

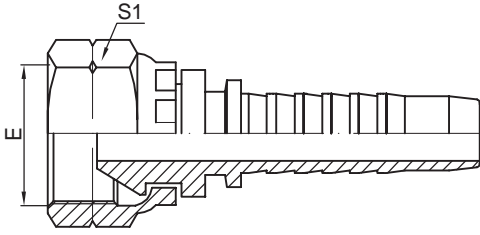

NPSM Female 30° Cone Straight

23811 SERIES	Thread	Hose Bore		Dimensions (mm)	
		<i>E</i>	<i>DN</i>	<i>Dash</i>	<i>S1</i>
ProPulse Fitting Part No.					
S23811-04-03	1/4"X18	5	3	19	
S23811-04-04	1/4"X18	6	4	19	
S23811-06-04	3/8"X18	6	4	22	
S23811-06-05	3/8"X18	8	5	22	
S23811-04-06	1/4"X18	10	6	19	
S23811-06-06	3/8"X18	10	6	22	
S23811-08-08	1/2"X14	12	8	27	
S23811-12-10	3/4"X14	16	10	32	
S23811-12-12	3/4"X14	19	12	32	
S23811-16-12	1"X11.5	19	12	41	
S23811-16-16	1"X11.5	25	16	41	
S23811-20-20	1.1/4"X11.5	32	20	50	
S23811-24-20	1.1/2"X11.5	32	20	55	
S23811-24-24	1.1/2"X11.5	38	24	55	
S23811-32-32	2"X11.5	50	32	70	

*Dimensions provided are nominal for reference only and may vary based on current supply.

BSP Female 60° Cone Straight

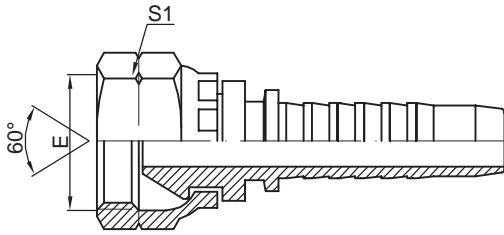

24811 SERIES ProPulse Fitting Part No.	Thread <i>E</i>	Hose Bore		Dimensions (mm) <i>S1</i>
		<i>DN</i>	<i>Dash</i>	
S24811-02-03	1/8"X28	5	3	14
S24811-04-03	1/4"X19	5	3	19
S24811-02-04	1/8"X28	6	4	14
S24811-04-04	1/4"X19	6	4	19
S24811-06-04	3/8"X19	6	4	22
S24811-04-05	1/4"X19	8	5	19
S24811-06-05	3/8"X19	8	5	22
S24811-04-06	1/4"X19	10	6	19
S24811-06-06	3/8"X19	10	6	22
S24811-08-06	1/2"X14	10	6	27
S24811-06-08	3/8"X14	12	8	22
S24811-08-08	1/2"X14	12	8	27
S24811-10-08	5/8"X14	12	8	30
S24811-12-08	3/4"X14	12	8	32
S24811-10-10	5/8"X14	16	10	30
S24811-12-10	3/4"X14	16	10	32
S24811-12-12	3/4"X14	19	12	32
S24811-16-12	1"X11	19	12	41
S24811-16-16	1"X11	25	16	41
S24811-20-16	1.1/4"X11	32	16	50
S24811-20-20	1.1/4"X11	32	20	50
S24811-24-20	1.1/2"X11	32	20	60
S24811-24-24	1.1/2"X11	38	24	60
S24811-32-24	2"X11	38	24	70
S24811-32-32	2"X11	50	32	70

*Dimensions provided are nominal for reference only and may vary based on current supply.

PROPULSE FITTING SOLUTIONS

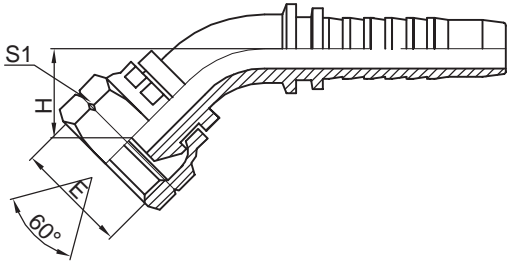

BSP Female 60° Cone 45° Elbow

24841 SERIES	Thread	Hose Bore		Dimensions (mm)		
		<i>E</i>	<i>DN</i>	<i>Dash</i>	<i>S1</i>	<i>H</i>
ProPulse Fitting Part No.						
S24841-04-04	1/4"X19	6	4	19	15	
S24841-06-04	3/8"X19	6	4	22	16	
S24841-06-05	3/8"X19	8	5	22	15	
S24841-06-06	3/8"X19	10	6	22	15	
S24841-08-06	1/2"X14	10	6	27	16	
S24841-08-08	1/2"X14	12	8	27	17	
S24841-10-08	5/8"X14	12	8	30	22.5	
S24841-12-08	3/4"X14	12	8	32	26	
S24841-10-10	5/8"X14	16	10	30	26	
S24841-12-10	3/4"X14	16	10	32	27	
S24841-12-12	3/4"X14	19	12	32	28	
S24841-16-12	1"X11	19	12	41	30	
S24841-16-16	1"X11	25	16	41	37	
S24841-20-16	1.1/4"X11	25	16	50	31	
S24841-20-20	1.1/4"X11	32	20	50	39	
S24841-24-24	1.1/2"X11	38	24	60	45	
S24841-32-32	2"X11	50	32	70	47	

*Dimensions provided are nominal for reference only and may vary based on current supply.

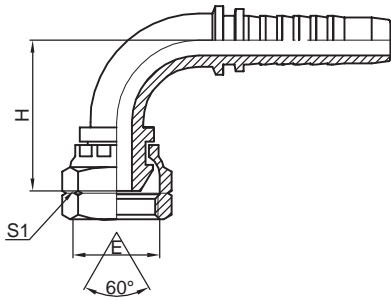

BSP Female 60° Cone 90° Elbow

24891 SERIES	Thread	Hose Bore		Dimensions (mm)	
		<i>DN</i>	<i>Dash</i>	<i>S1</i>	<i>H</i>
ProPulse Fitting Part No.	<i>E</i>				
S24891-04-04	1/4"X19	6	4	19	29
S24891-06-04	3/8"X19	6	4	22	31
S24891-04-05	1/4"X19	8	5	19	29.5
S24891-06-05	3/8"X19	8	5	22	27.5
S24891-04-06	1/4"X19	10	6	17	31.5
S24891-06-06	3/8"X19	10	6	22	31.5
S24891-08-06	1/2"X14	10	6	27	32
S24891-06-08	3/8"X19	12	8	22	41
S24891-08-08	1/2"X14	12	8	27	36
S24891-10-08	5/8"X14	12	8	30	44
S24891-12-08	3/4"X14	12	8	32	45.5
S24891-08-10	1/2"X14	16	10	27	55
S24891-10-10	5/8"X14	16	10	30	53.5
S24891-12-10	3/4"X14	16	10	32	55
S24891-12-12	3/4"X14	19	12	32	60
S24891-16-12	1"X11	19	12	41	62
S24891-16-16	1"X11	25	16	41	76
S24891-20-16	1.1/4"X11	25	16	50	78
S24891-20-20	1.1/4"X11	32	20	50	84
S24891-20-24	1.1/4"X11	38	24	70	90
S24891-24-24	1.1/2"X11	38	24	60	99
S24891-32-24	2"X11	40	24	70	125
S24891-32-32	2"X11	50	32	70	110

*Dimensions provided are nominal for reference only and may vary based on current supply.

PROPULSE FITTING SOLUTIONS

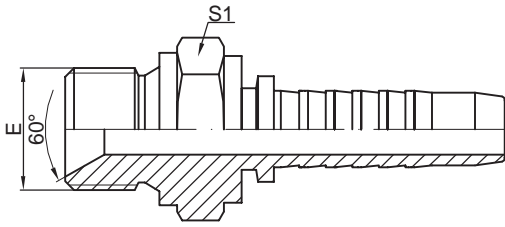

BSP Male 60° Cone Straight

14811 SERIES	Thread	Hose Bore		Dimensions (mm)	
		<i>E</i>	<i>DN</i>	<i>Dash</i>	<i>S1</i>
ProPulse Fitting Part No.					
S14811-02-03	1/8"X28	5	3	14	
S14811-02-04	1/8"X28	6	4	14	
S14811-04-04	1/4"X19	6	4	19	
S14811-06-04	3/8"X19	6	4	22	
S14811-06-05	3/8"X19	8	5	22	
S14811-04-06	1/4"X19	10	6	19	
S14811-06-06	3/8"X19	10	6	22	
S14811-08-06	1/2"X14	10	6	27	
S14811-06-08	3/8"X19	12	8	22	
S14811-08-08	1/2"X14	12	8	27	
S14811-10-08	5/8"X14	12	8	30	
S14811-12-08	3/4"X14	12	8	32	
S14811-10-10	5/8"X14	16	10	30	
S14811-12-10	3/4"X14	16	10	32	
S14811-12-12	3/4"X14	19	12	32	
S14811-16-12	1"X11	19	12	41	
S14811-16-16	1"X11	25	16	41	
S14811-20-16	1.1/4"X11	25	16	50	
S14811-20-20	1.1/4"X11	32	20	50	
S14811-24-20	1.1/2"X11	32	20	60	
S14811-24-24	1.1/2"X11	38	24	60	
S14811-32-32	2"X11	50	32	70	

*Dimensions provided are nominal for reference only and may vary based on current supply.

PROPULSE FITTING SOLUTIONS

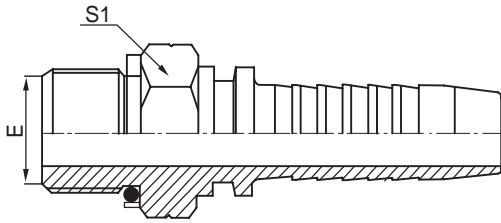

BSPP Male O-Ring Flat Seal Straight

14411 SERIES	Thread	Hose Bore		Dimensions (mm)	
		<i>E</i>	<i>DN</i>	<i>Dash</i>	<i>S1</i>
ProPulse Fitting Part No.					
S14411-04-04	1/4"X19	6	4	17	
S14411-08-04	1/2"X14	6	4	27	
S14411-04-06	1/4"X19	10	6	19	
S14411-06-06	3/8"X19	10	6	22	
S14411-08-06	1/2"X14	10	6	27	
S14411-08-08	1/2"X14	12	8	27	
S14411-10-10	5/8"X14	16	10	30	
S14411-12-10	3/4"X14	16	10	32	
S14411-12-12	3/4"X14	19	12	32	
S14411-12-16	3/4"X14	25	16	32	
S14411-16-16	1"X11	25	16	41	
S14411-20-20	1.1/4"X11	32	20	50	

*Dimensions provided are nominal for reference only and may vary based on current supply.

PROPULSE FITTING SOLUTIONS

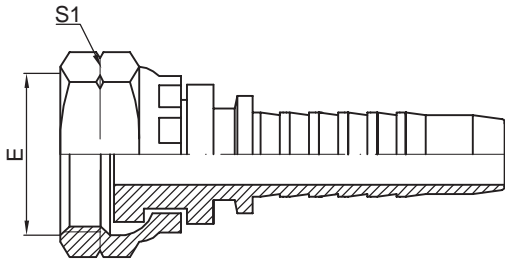

BSP Female Flat Seal Straight

24411 SERIES	Thread	Hose Bore		Dimensions (mm)	
		<i>E</i>	<i>DN</i>	<i>Dash</i>	<i>S1</i>
ProPulse Fitting Part No.					
S24411-04-04	1/4"X19	6	4	19	
S24411-06-04	3/8"X19	6	4	22	
S24411-06-05	3/8"X19	8	5	22	
S24411-04-06	1/4"X19	10	6	19	
S24411-06-06	3/8"X19	10	6	22	
S24411-08-06	1/2"X14	10	6	27	
S24411-06-08	3/8"X19	12	8	22	
S24411-08-08	1/2"X14	12	8	27	
S24411-10-08	5/8"X14	12	8	30	
S24411-12-08	3/4"X14	12	8	32	
S24411-10-10	5/8"X14	16	10	30	
S24411-12-10	5/8"X14	16	10	30	
S24411-12-12	3/4"X14	19	12	32	
S24411-16-12	1"X11	19	12	41	
S24411-16-16	1"X11	25	16	41	
S24411-20-20	1.1/4"X11	32	20	50	
S24411-24-24	1.1/2"X11	38	24	60	
S24411-32-32	2"X11	50	32	70	

*Dimensions provided are nominal for reference only and may vary based on current supply.

PROPULSE FITTING SOLUTIONS

BSPT Male Straight

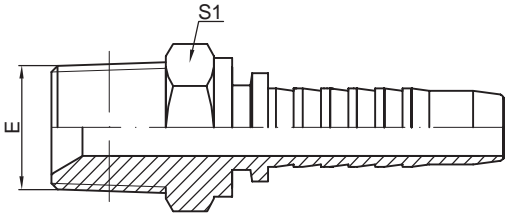

15211 SERIES	Thread	Hose Bore		Dimensions (mm)	
		<i>E</i>	<i>DN</i>	<i>Dash</i>	<i>S1</i>
ProPulse Fitting Part No.					
S15211-02-04	1/8"X28	6	4	12	
S15211-04-04	1/4"X19	6	4	14	
S15211-06-04	3/8"X19	6	4	19	
S15211-04-05	1/4"X19	8	5	14	
S15211-06-05	3/8"X19	8	5	19	
S15211-04-06	1/4"X19	10	6	14	
S15211-06-06	3/8"X19	10	6	19	
S15211-08-06	1/2"X14	10	6	22	
S15211-06-08	3/8"X19	12	8	19	
S15211-08-08	1/2"X14	12	8	22	
S15211-12-08	3/4"X14	12	8	27	
S15211-08-10	1/2"X14	16	10	22	
S15211-12-10	3/4"X14	16	10	27	
S15211-08-12	1/2"X14	19	12	22	
S15211-12-12	3/4"X14	19	12	27	
S15211-16-12	1"X11	19	12	36	
S15211-12-16	3/4"X14	25	16	27	
S15211-16-16	1"X11	25	16	36	
S15211-20-20	1.1/4"X11	32	20	46	
S15211-24-24	1.1/2"X11	38	24	50	
S15211-32-24	2"X11	38	24	65	
S15211-32-32	2"X11	50	32	65	

*Dimensions provided are nominal for reference only and may vary based on current supply.

PROPULSE FITTING SOLUTIONS

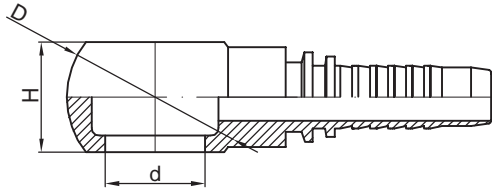

BSP Banjo

74211 SERIES ProPulse Fitting Part No.	Bolt Size	Hose Bore		Dimensions (mm)		
		DN	Dash	d	D	H
S74211-02-03	1/8"X28	5	3	9.9	22	16
S74211-04-03	1/4"X19	5	3	13.3	24	15
S74211-02-04	1/8"X28	6	4	9.9	22	16
S74211-04-04	1/4"X19	6	4	13.3	24	15
S74211-03-04	3/8"X19	6	4	16.7	29	20
S74211-04-05	1/4"X19	8	5	13.3	24	15
S74211-06-05	3/8"X19	8	5	16.7	29	20
S74211-08-05	1/2"X14	8	5	21	38	25
S74211-04-06	1/4"X19	10	6	13.3	24	15
S74211-06-06	3/8"X19	10	6	16.7	29	20
S74211-08-06	1/2"X14	10	6	21	38	25
S74211-06-08	3/8"X19	12	8	16.7	29	20
S74211-08-08	1/2"X14	12	8	21	38	25
S74211-16-08	1"X11	12	8	33.3	60	42
S74211-08-10	1/2"X14	16	10	21	38	25
S74211-10-10	5/8"X14	16	10	23	40	27
S74211-12-10	3/4"X14	16	10	26.5	48	31
S74211-12-12	3/4"X14	19	12	26.5	48	31
S74211-16-12	1"X11	19	12	33.3	60	42
S74211-16-16	1"X11	25	16	33.3	60	42

*Dimensions provided are nominal for reference only and may vary based on current supply.

PROPULSE FITTING SOLUTIONS

SAE Code 61 3000PSI Flange Straight
SAE J516/J518

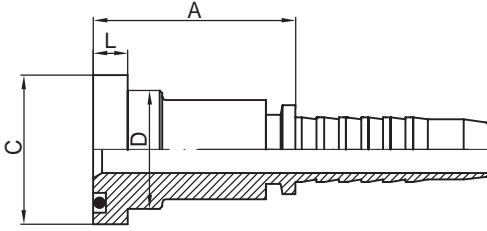

89511 SERIES ProPulse Fitting Part No.	Flange Size	Hose Bore		Dimensions (mm)			
		DN	Dash	A	C	D	L
S89511-08-08	1/2"	12	8	46	30.2	24	6.73
S89511-12-08	3/4"	12	8	47	38.1	31.7	6.73
S89511-12-10	3/4"	16	10	48	38.1	31.7	6.73
S89511-12-12	3/4"	19	12	48	38.1	31.7	6.73
S89511-16-12	1"	19	12	51	44.5	38	8
S89511-12-16	3/4"	25	16	49	38.1	31.7	6.73
S89511-16-16	1"	25	16	52	44.5	38	8
S89511-20-16	1.1/4"	25	16	57	50.8	43	8
S89511-16-20	1"	32	20	53	44.5	38	8
S89511-20-20	1.1/4"	32	20	58	50.8	43	8
S89511-24-20	1.1/2"	32	20	68	60.3	50	8
S89511-24-24	1.1/2"	38	24	68	60.3	50	8
S89511-32-24	2"	38	24	70	71.4	62	9.53
S89511-32-32	2"	50	32	70	71.4	62	9.53

*Dimensions provided are nominal for reference only and may vary based on current supply.

PROPULSE FITTING SOLUTIONS

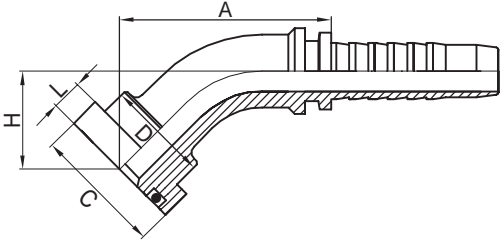

SAE Code 61 3000PSI Flange 45° Elbow
SAE J516/J518

89541 SERIES	Flange Size	Hose Bore		Dimensions (mm)				
		DN	Dash	A	C	D	H	L
ProPulse Fitting Part No.								
S89541-08-08	1/2"	12	8	58.2	30.2	24	19	6.73
S89541-12-08	3/4"	12	8	58.9	38.1	31.7	26	6.73
S89541-12-10	3/4"	16	10	70.1	38.1	31.7	26	6.73
S89541-12-12	3/4"	19	12	77	38.1	31.7	26	6.73
S89541-16-12	1"	19	12	77	44.5	38	28	8
S89541-16-16	1"	25	16	85.2	44.5	38	28	8
S89541-20-16	1.1/4"	25	16	85.2	50.8	43	32	8
S89541-16-20	1"	32	20	94.5	44.5	38	28	8
S89541-20-20	1.1/4"	32	20	94.5	50.8	43	32	8
S89541-24-20	1.1/2"	32	20	95.9	60.3	50	38	8
S89541-24-24	1.1/2"	38	24	109.9	60.3	50	38	8
S89541-32-24	2"	38	24	109.9	71.4	62	52	9.53
S89541-32-32	2"	50	32	129.3	71.4	62	52	9.53

*Dimensions provided are nominal for reference only and may vary based on current supply.

PROPULSE FITTING SOLUTIONS

SAE Code 61 3000PSI Flange 90° Elbow
SAE J516/J518

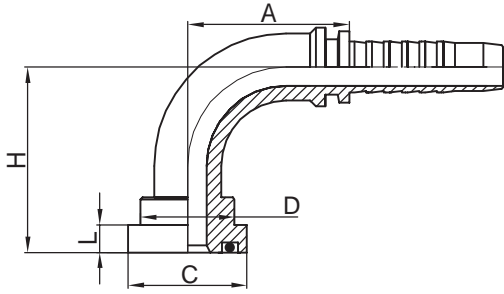

89591 SERIES ProPulse Fitting Part No.	Flange Size	Hose Bore		Dimensions (mm)				
		DN	Dash	A	C	D	H	L
S89591-08-08	1/2"	12	8	41	30.2	24	40	6.73
S89591-12-08	3/4"	12	8	41	38.1	31.7	58	6.73
S89591-12-10	3/4"	16	10	56.5	38.1	31.7	58	6.73
S89591-12-12	3/4"	19	12	66.2	38.1	31.7	58	6.73
S89591-16-12	1"	19	12	66.2	44.5	38	61	8
S89591-12-16	3/4"	25	16	76.7	38.1	31.7	58	6.73
S89591-16-16	1"	25	16	78	44.5	38	61	8
S89591-20-16	1.1/4"	25	16	78	50.8	43	68	8
S89591-16-20	1"	32	20	91.5	44.5	38	61	8
S89591-20-20	1.1/4"	32	20	91.5	50.8	43	68	8
S89591-24-20	1.1/2"	32	20	91.5	60.3	50	81	8
S89591-20-24	1.1/4"	38	24	108.5	50.8	43	68	8
S89591-24-24	1.1/2"	38	24	109.4	60.3	50	81	8
S89591-32-24	2"	38	24	109.4	71.4	62	120	9.53
S89591-32-32	2"	50	32	131.8	71.4	62	120	9.53
S89591-40-32	2.1/2"	50	32	131.8	84.1	74.4	118	9.53

*Dimensions provided are nominal for reference only and may vary based on current supply.

PROPULSE FITTING SOLUTIONS

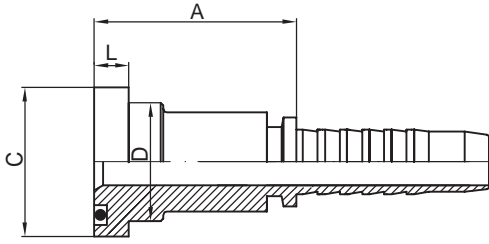

**SAE Code 62 6000PSI Flange Straight
SAE J516/J518**

89811 SERIES ProPulse Fitting Part No.	Flange Size	Hose Bore		Dimensions (mm)				
		DN	Dash	A	C	D	H	L
S89811-08-08	1/2"	12	8	47	31.8	24	7.75	6.73
S89811-12-10	3/4"	16	10	51	41.3	32	8.76	6.73
S89811-12-12	3/4"	19	12	51	41.3	32	8.76	6.73
S89811-16-12	1"	19	12	56	47.6	38	9.53	6.73
S89811-16-16	1"	25	16	57	47.6	38	9.53	8
S89811-20-16	1.1/4"	25	16	65	54	44	10.29	8
S89811-16-20	1"	32	20	61	47.6	38	9.53	8
S89811-20-20	1.1/4"	32	20	66	54	44	10.29	8
S89811-24-20	1.1/2"	32	20	75	63.5	51	12.57	8
S89811-24-24	1.1/2"	38	24	75	63.5	51	12.57	8
S89811-32-24	2"	38	24	85	79.4	67	12.57	8
S89811-32-32	2"	50	32	85	79.4	67	12.57	9.53

*Dimensions provided are nominal for reference only and may vary based on current supply.

PROPULSE FITTING SOLUTIONS

SAE Code 62 6000PSI Flange 45° Elbow
SAE J516/J518

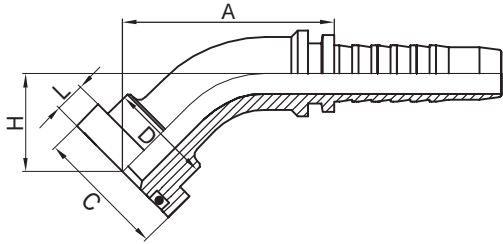

89841 SERIES ProPulse Fitting Part No.	Flange Size	Hose Bore		Dimensions (mm)				
		DN	Dash	A	C	D	H	L
S89841-08-08	1/2"	12	8	58.9	31.8	24	19	7.75
S89841-12-10	3/4"	16	10	72.5	41.3	32	26	8.76
S89841-08-12	1/2"	19	12	74.9	31.8	24	26	7.75
S89841-12-12	3/4"	19	12	79.2	41.3	32	26	8.76
S89841-16-12	1"	19	12	79.2	47.6	38	28	9.53
S89841-16-16	1"	25	16	90.2	47.6	38	28	9.53
S89841-20-16	1.1/4"	25	16	96.2	54	44	32	10.29
S89841-20-20	1.1/4"	32	20	103.8	54	44	32	10.29
S89841-24-20	1.1/2"	32	20	105.8	63.5	51	38	12.57
S89841-24-24	1.1/2"	38	24	116.2	63.5	51	38	12.57
S89841-32-24	2"	38	24	125.4	79.4	67	52	12.57
S89841-32-32	2"	50	32	135.7	79.4	67	52	12.57

*Dimensions provided are nominal for reference only and may vary based on current supply.

PROPULSE FITTING SOLUTIONS

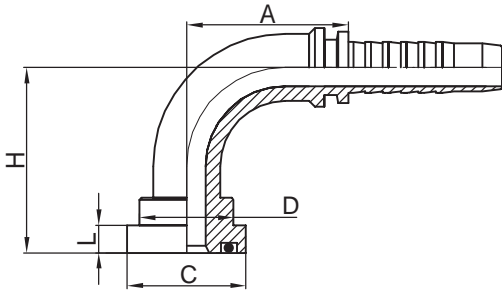

SAE Code 62 6000PSI Flange 90° Elbow
SAE J516/J518

89891 SERIES	Flange Size	Hose Bore		Dimensions (mm)				
		DN	Dash	A	C	D	H	L
ProPulse Fitting Part No.								
S89891-08-08	1/2"	12	8	41	31.8	24	40	7.75
S89891-12-10	3/4"	16	10	56.5	41.3	32	58	8.76
S89891-12-12	3/4"	19	12	66.2	41.3	32	58	8.76
S89891-16-12	1"	19	12	66.2	47.6	38	70	9.53
S89891-16-16	1"	25	16	78	47.6	38	61	9.53
S89891-20-16	1.1/4"	25	16	78	54	44	68	10.29
S89891-16-20	1"	32	20	91.5	47.6	38	61	9.53
S89891-20-20	1.1/4"	32	20	91.5	54	44	68	10.29
S89891-24-20	1.1/2"	32	20	91.5	63.5	51	81	12.57
S89891-24-24	1.1/2"	38	24	109.4	63.5	51	81	12.57
S89891-32-24	2"	38	24	109.4	79.4	67	120	12.57
S89891-32-32	2"	50	32	131.8	79.4	67	120	12.57

*Dimensions provided are nominal for reference only and may vary based on current supply.

PROPULSE FITTING SOLUTIONS

Standard ORB Male Solid
SAE J514/J516

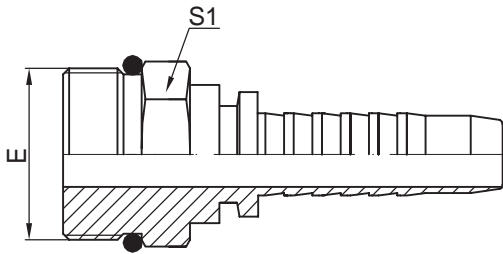

18211 SERIES ProPulse Fitting Part No.	Thread	Hose Bore		Dimensions (mm)	
		DN	Dash	S1	
S18211-04-04	7/16"X20	6	4	14	
S18211-05-04	1/2"X20	6	4	17	
S18211-06-05	9/16"X18	8	5	17	
S18211-06-06	9/16"X18	10	6	17	
S18211-08-06	3/4"X16	10	6	22	
S18211-08-08	3/4"X16	12	8	22	
S18211-10-08	7/8"X14	12	8	27	
S18211-10-10	7/8"X14	16	10	27	
S18211-12-10	1.1/16"X12	16	10	32	
S18211-12-12	1.1/16"X12	19	12	32	
S18211-16-16	1.5/16"X12	25	16	41	

*Dimensions provided are nominal for reference only and may vary based on current supply.

PROPULSE FITTING SOLUTIONS

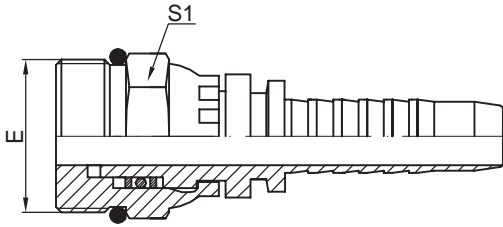

**Standard ORB Male Swivel
SAE J514/J516**

18211W SERIES	Thread	Hose Bore		Dimensions (mm)	
		DN	Dash	S1	
ProPulse Fitting Part No.					
S18211W-04-04	7/16"X20	6	4	14	
S18211W-06-04	9/16"X18	6	4	17	
S18211W-06-06	9/16"X18	10	6	17	
S18211W-08-06	3/4"X16	10	6	22	
S18211W-08-08	3/4"X16	12	8	22	
S18211W-10-08	7/8"X14	12	8	27	
S18211W-12-08	1.1/16"X12	12	8	32	
S18211W-10-10	7/8"X14	16	10	27	
S18211W-12-12	1.1/16"X12	19	12	32	

*Dimensions provided are nominal for reference only and may vary based on current supply.

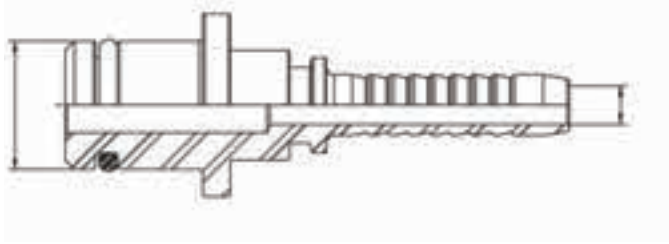

Pressure Washer Nipple

33313 SERIES	Nominal Correction	Hose Bore		Dimensions (mm)	
		DN	Dash	Shoulder	I.D.
ProPulse Fitting Part No.	NC				
S33313-14-04	14	6	4	20	4.0
S33313-14-05	14	8	5	20	6.0
S33313-14-06	14	10	6	20	7.0
S33313-15-04	15	6	4	20	4.0
S33313-15-08	15	8	5	20	6.3

*Dimensions provided are nominal for reference only and may vary based on current supply.

PROPULSE FITTING SOLUTIONS

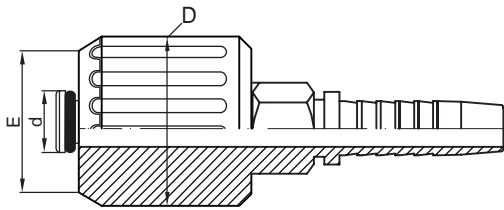

M22 Live Swivel

23313LS SERIES	Thread	Hose Bore		Dimensions (mm)		
		<i>E</i>	<i>DN</i>	<i>Dash</i>	<i>d</i>	<i>D</i>
ProPulse Fitting Part No.						
S23313LS-22-08	M22X1.5	8	5	14	37.5	
S23313LS-22-10	M22X1.5	10	6	14	37.5	

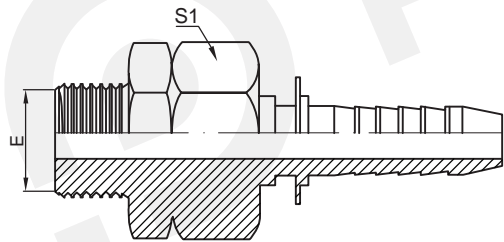

NPT Live Swivel

178163LS SERIES	Thread	Hose Bore		Dimensions (mm)	
		<i>E</i>	<i>DN</i>	<i>Dash</i>	<i>S1</i>
ProPulse Fitting Part No.					
S17813LS-06-06	3/8"X18	10	6	27	

*Dimensions provided are nominal for reference only and may vary based on current supply.



WARNING

Improper selection or improper use of hose, fittings, assemblies or related accessories ("Products") can cause death, personal injury and property damage. Possible consequences of failure or improper selection or improper use of these Products include but are not limited to:

- › Fittings thrown off at high speed.
- › High velocity fluid discharge.
- › Explosion or burning of the conveyed fluid.
- › Electrocutation from high voltage electric powerlines.
- › Contact with suddenly moving or falling objects that are controlled by the conveyed fluid.
- › Injections by high-pressure fluid discharge.
- › Dangerously whipping Hose.
- › Contact with conveyed fluids that may be hot, cold, toxic or otherwise injurious.
- › Sparking or explosion caused by static electricity buildup or other sources of electricity.
- › Sparking or explosion while spraying paint or flammable liquids.
- › Injuries resulting from inhalation, ingestion or exposure to fluids.

Before selecting or using any ProPulse Products, it is important that you read and understand the following.

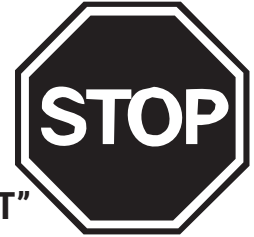

IF YOU SEE "IT" – STOP "IT"

FAILURE TO PROPERLY REPAIR OR REPLACE HOSE AFTER EXPOSING BRAID REINFORCEMENT LAYER CAN CAUSE DEATH, PERSONAL INJURY AND PROPERTY DAMAGE. LIKE STRANDS IN A BRIDGE CABLE, EACH REINFORCEMENT FIBER PLAYS AN EXACT ROLE IN THE ULTIMATE BURST STRENGTH OF THE HOSE. A MINOR SLICE OR NICK IN THE REINFORCEMENT CAN RESULT IN TOTAL HOSE FAILURE.

THE AGE OF THE HOSE DOES NOT MATTER! IT IS UNFORTUNATE, BUT EVEN HOSE USED ONE (1) TIME CAN BE DAMAGED IN SEVERE APPLICATIONS. THESE HOSES MUST BE IMMEDIATELY REMOVED FROM SERVICE.

HOSE BASICS

1. NEVER EXCEED THE MAXIMUM WORKING PRESSURE.
2. NEVER EXCEED THE MAXIMUM WORKING TEMPERATURE.
3. NEVER APPLY PRESSURE TO A DAMAGED HOSE.
4. HIGH PRESSURE HOSES ARE DESIGNED TO USE SPECIFIC FITTINGS OR TOOLING. NEVER USE A DIFFERENT BRAND OF FITTINGS TO TOOLING. FAILURE TO DO SO CAN CAUSE DEATH, PERSONAL INJURY AND/OR PROPERTY DAMAGE.
5. A KINKED, CRUSHED, OR BLISTERED HOSE WILL EVENTUALLY FAIL – DO NOT RISK INJURY. IMMEDIATELY REPAIR OR REMOVE HOSE FROM SERVICE.
6. FOLLOW THE PUMP/EQUIPMENT MANUFACTURERS INSTRUCTIONS FOR PRESSURIZED HOSE TESTING.

PROPULSE LIMITED WARRANTY

Subject to the limitations stated herein, Schieffer Co. International, L.C., dba ProPulse (Seller) warrants that the products manufactured by Seller identified below shall be free from material defects in materials and workmanship and shall perform the services for which they are intended when properly installed, under normal use, and under ordinary conditions, for:

HYDRAULIC HOSE: A period of 365 days from the date of shipment of the product to BUYER.

HIGH PRESSURE CLEANING HOSE: A period of 180 days from the shipment of the product to the BUYER.

Buyer must notify Seller in writing of a potentially defective product as soon as possible, which notice must provide the appropriate marked date codes, part numbers of the product and a description of the potential defect. Upon receipt of such notice, Seller shall, at its option and at its expense, examine such product at Seller's factory or such other location as Seller shall determine. Should Seller agree to a return of the product, Buyer shall follow in every respect the packaging and transportation instructions provided by Seller. In no case shall a product be returned without first obtaining the permission of Seller. If a product is proven to the satisfaction of Seller to be defective, then Seller shall, at its option and at its expense, repair or replace such product or reimburse Buyer for the price paid by Buyer for such product, and credit will be issued to Buyer to offset the expense of the return shipment to Seller for shipments within the continental United States. The cost of shipping to Buyer a repaired or replaced product shall be paid by Seller on the same shipping terms as the original shipment of such product to Buyer. Except as stated herein, Buyer shall assume all responsibility and expense for any dismantling, removal, reinstallation, and shipping in connection with this Limited Warranty, and no claims will be allowed for labor, shipping, materials, incidental, consequential, or other costs incident to the repair, replacement, or return of a product.

THIS LIMITED WARRANTY IS THE ONLY WARRANTY PROVIDED BY SELLER AND IS MADE IN LIEU OF ALL OTHER WARRANTIES, EXPRESS OR IMPLIED, INCLUDING BUT NOT LIMITED TO THE IMPLIED WARRANTIES OF MERCHANTABILITY AND FITNESS FOR A PARTICULAR PURPOSE AND THOSE ARISING BY OPERATION OF LAW, TRADE USAGE, OR COURSE OF DEALING.

NOTWITHSTANDING THE FOREGOING, THERE ARE NO WARRANTIES WHATSOEVER ON PRODUCTS BUILT OR ACQUIRED WHOLLY OR PARTIALLY TO BUYER'S DESIGNS OR SPECIFICATIONS.

SELLER'S LIABILITY IS LIMITED TO REPAIR, REPLACEMENT, OR REIMBURSEMENT AS PROVIDED ABOVE, AND IN NO EVENT SHALL

SELLER'S LIABILITY EXCEED THE PURCHASE PRICE OF THE PRODUCT(S) INVOLVED. THIS LIMITED WARRANTY PROVIDES THE EXCLUSIVE REMEDY AGAINST SELLER FOR CLAIMS RELATING TO PRODUCTS, WHETHER IN CONTRACT, IN TORT (INCLUDING NEGLIGENCE), OR UNDER ANY OTHER LEGAL THEORY, AND WHETHER ARISING OUT OF WARRANTIES, REPRESENTATIONS, INSTRUCTIONS, OR DEFECTS FROM ANY CAUSE. IN NO EVENT SHALL SELLER BE LIABLE FOR OR OBLIGATED TO PAY ANY CONSEQUENTIAL, INCIDENTAL, SPECIAL, INDIRECT, OR PUNITIVE DAMAGES OF ANY KIND, INCLUDING, BUT NOT LIMITED TO LOST PROFITS.

THIS LIMITED WARRANTY EXTENDS ONLY TO BUYERS WHO PURCHASE SELLER'S PRODUCT(S) DIRECTLY FROM SELLER ("ORIGINAL PURCHASERS"), INCLUDING MANUFACTURERS, RETAILERS, DEALERS, DISTRIBUTORS AND WHOLESALERS. THIS LIMITED WARRANTY IS NOT ASSIGNABLE OR OTHERWISE TRANSFERRABLE BY THE ORIGINAL PURCHASER TO ANY OTHER PARTY. SELLER EXTENDS NO WARRANTY, EXPRESS OR IMPLIED, INCLUDING BUT NOT LIMITED TO THE IMPLIED WARRANTIES OF MERCHANTABILITY AND FITNESS FOR A PARTICULAR PURPOSE, TO "CONSUMERS," AS THAT TERM IS DEFINED IN THE MAGNUSON-MOSS WARRANTY ACT (15 U.S.C. SECTIONS 2301 ET SEQ.) AND THE REGULATIONS PROMULGATED THEREUNDER. IN NO EVENT SHALL THE DURATION OF ANY IMPLIED WARRANTY OF MERCHANTABILITY OR FITNESS FOR A PARTICULAR PURPOSE BE LONGER THAN THE PERIOD PRESCRIBED HEREIN.

This Limited Warranty shall not apply to product failure or defect: caused by external or internal abrasion, kinking, twisting, cutting, pulling, impact, use for the transfer or spray of flammable materials (including solvents, petroleum, and gases of any kind), use with fluids which exceed the product's labeled pressure or temperature limits, storm, fire, wind, accident, or similar casualty; where the product has been modified without the prior written authority of Seller; caused by installation or use of the product contrary to any instructions or specifications provided by Seller; caused by the improper installation, use, application, maintenance, repair, transportation, handling, or storage of the product; caused by the fault or negligence of anyone other than Seller or any other act or event beyond the control of Seller. Seller makes no warranties as to any products or product parts or components that are not manufactured by Seller, and such items may be warranted only to the extent of the original manufacturer's warranty, if any. The limitations of liability contained in this Limited Warranty shall be effective without regard to Seller's performance or failure or delay of performance under any other term or condition of any trade customs, warranty, or other agreement. No employee, representative, or agent of Seller, nor any other person, has authority to assume or incur on behalf of Seller any liability, obligation, or responsibility in place of or in addition to this Limited Warranty.