

ZEISS SmartLife Lenses

New Technologies for New Times

In today's connected & on-the-move lifestyle, our visual behavior is dynamic with frequent gaze changes between various directions and distances. We combined the visual requirements of our modern lifestyle with its related dynamic visual behavior and the age-related vision needs. ZEISS Vision Care translated these requirements into a complete premium lens portfolio for a connected & on-the-move life - no matter the age.



Seeing beyond

ZEISS SmartLife Lenses

With the launch of ZEISS SmartLife lenses, ZEISS has adapted and advanced its lens designs for today's dynamically connected lifestyle. ZEISS SmartView Technology is a realignment of design goals to keep up with the fast pace of change. ZEISS Smart Dynamic Optics deploy an object-space model to account for a dynamic visual behavior from very close to very far and flattens the distribution of dioptric power in the lens periphery to allow smoother, clearer vision needed for frequent changes of head and eye posture driven by the way in which people interact with their handheld devices. Age Intelligence applies ZEISS research and experience on the capabilities of adults of all ages to adapt each lens design according to changes in pupil size and dynamic accommodation depending on the wearer's age. ZEISS SmartLife Lenses are a single solution comprising single vision, digital, and progressive lenses that are ideal for all of today's active, connected adults.

New Demands Arising From Dynamic Connectivity

The World Wide Web was created thirty years ago. An entire generation has grown to adulthood not knowing what it is like to be disconnected from the rest of the world. The pace of communication and information technology has continued without slowing down. This technology connects and transforms modern life with streams of parallel interactivity.

Some people regret the change. Things were simpler in the past. Life was a series of events happening one after the other: do your job, read a book, meet with friends. Although the telephone might ring when you were doing any of these things, the phone did not require your complete visual attention. Now our phones are total communication devices that require both visual and auditory attention, and they do so in parallel with the other things we are doing. Some people may call this "multi-tasking," but that word does not explain how the external world's direct connection to us affects the choice of activities that we will do at any moment. It may be better described as a condition of dynamic connectivity.

Dynamic connectivity does not discriminate by age. Whether you are of age 20 or 60, your smartphone, fitness tracker, automobile infotainment system and other connected information devices compete for your attention with alerts and notifications. Adults of all ages own a smartphone and use it while socializing, taking public transportation and working.^[1] In fact, the fastest growing segment of smartphone users is among people older than age 55.^[2] The change in habits presents a challenge to the eyecare professions.

Recognizing this major change in lifestyle wasn't difficult for scientists at ZEISS. They could see it from the moment they awoke in the morning until they fell asleep at night. They and their family and friends have become attached to their devices. You can see it in the way people won't break their digital connections even when climbing stairs or crossing a street. This is a new pattern, presenting new challenges. Dynamic connectivity has created habits that force new thinking about lenses.

Connected devices started to change visual habits over the last decade. Handheld digital devices had smaller and higher

resolution displays than personal computers and displayed finer details than most printed books. Researchers showed that when viewing web content on a smartphone^[3], typical viewing distances were about 32 cm, closer than the distance at which refractions are typically performed and closer than the distance for which multifocal lenses were designed. ZEISS Digital Inside[®] Technology first addressed this problem five years ago.

The initial response by spectacle lens designers to this new habit was to view it as a traditional reading behavior but with a closer viewing distance. Such behavior was presumed to be stationary. But dynamic connectivity now encourages people to use handheld devices in all situations, even while walking. More than half of all participants in a recent study reported using and looking at their smartphones even while climbing stairs; visual attention strongly shifts to the smartphone display during this activity.^[4] At first, this behavior seemed quite surprising because one would think that such behavior would lead to frequent accidents. In spite of the demand of devices on visual attention, people who walk while using handheld devices can do so by relying on a combination of central and peripheral vision to navigate.^[5]

The most popular connected devices require our hands for control and input. The most comfortable position keeps arms and elbows close to the body. This movement brings our hands closer to the torso and well below the head. A recent five-year study showed that users of handheld devices must bend the upper spine and tip the head forward to adapt to this position.^[6] But bending the neck forward is not a sufficient adaptation to smartphones, because additional downward eye rotation is necessary to see the screen. A recent ZEISS research study showed that spectacle wearers using smartphones turn their eyes to look lower through their lenses. This is true for several activities including desk work, conversation and walking. One consequence of this change is that wearers use a larger area of their lenses for visual fixations.^{ZEISS Study 1} Figure 1 shows the measurements ZEISS made on the difference in eye movement patterns when using a mobile device.

On the left, the blue contours represent eye positions when doing desk work, when having a conversation or while walking. On the right, the same activities were repeated allowing for the

usage of a smartphone. The blue lines show eye movements when not looking at the phone while the red lines represent eye movements when looking at the phone. Eye movements when using the smartphone were shifted significantly downward. Mobile devices constantly draw attention to themselves. At any moment an incoming message may require the multitasking user to process new information. To do so, the user has learned to adopt new patterns of body posture and eye movements. Until now, spectacle lens designs have ignored problems created by these new habits.

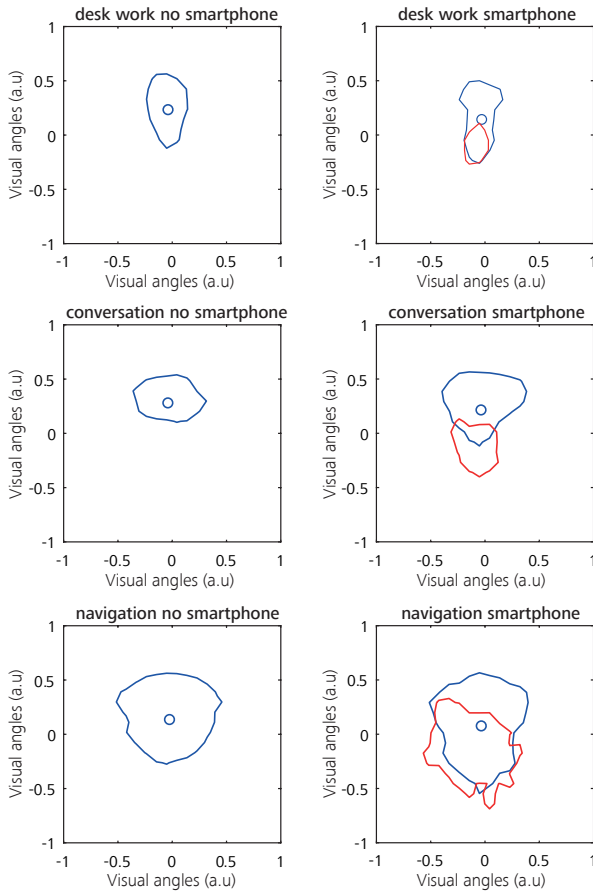

Figure 1 Eye movements with and without smartphones. Scale represents eye rotation in arbitrary units. Blue and red lines represent border including 75% of eye rotation directions in the respective task. Blue lines considered eye positions, in which the gaze was not on a smartphone, red lines considered solely gaze, in which the gaze was on smartphone. ^{ZEISS Study1}

Changing Visual Abilities According to Age

Traditional ophthalmic optics teaches that accommodative amplitude declines with age until the reserve of accommodation no longer allows sustained and comfortable close focus. Figure 2 shows a graph of the distribution of monocular amplitude of accommodation as a function of age. In order to provide spectacles that allow at least a 50% reserve of accommodation, most people would require an addition power by age forty when looking at very close objects. This is a monocular perspective that does not appreciate dynamic vision.

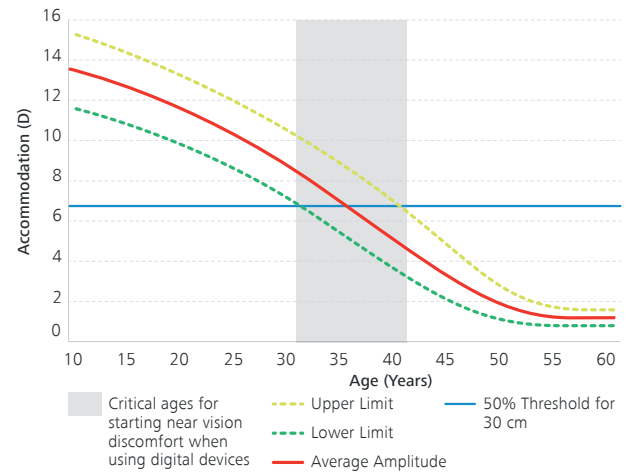

Figure 2 The traditional view of accommodation is monocular^[7]

Accommodation is part of a multifactor binocular visual reflex that changes with age. There are two fast components of accommodation: the stronger component is driven by binocular convergence while the weaker component is a response to blur. The dynamics of these responses depend on whether vision changes from far to near ("accommodation") or from near to far ("dis-accommodation").^[8] Also in young people the accommodation amplitude is greater when the head is pointing face-down, but this effect is not observed in older people.^[9] This fact could be important for mobile device use, when the head is often pointed downward.

As people age, the convergence-accommodation complex undergoes multiple changes, but the ones most likely to affect spectacle lens design are increasing depth of focus and therefore a reduced input to blur-driven accommodation, reduced convergence-accommodation to convergence ratio (CA/C) and a slower response reaction time.^[10] The stages of progression through changes in the accommodative convergence response have traditionally been addressed by separate spectacle lens products, including single vision, digital and progressive addition lenses. These types of lenses and their uses are well known to eyecare professionals. At first, young lens wearers have very responsive and flexible accommodation and require only a single focus, provided by a single vision lens. As people transition from youth to old age, they arrive at a stage where accommodative flexibility is reduced. The lack of accommodative facility can cause binocular vision stress because convergence and divergence remain fast and accurate while focus lags. This is particularly true for close viewing of handheld devices. Some people become symptomatic, complaining of eyestrain or blurry vision, and the solution is to provide a small amount of addition power. This need was first addressed by ZEISS when it introduced ZEISS Digital lenses. The specific application of this new lens type was further confirmed in a recent study conducted by the Aston Optometry School of Aston University (UK). The researchers found that ZEISS SmartLife Digital Lenses significantly improved

the accommodative response, thereby providing a more accurate vision and reducing the lag of accommodation for near stimuli (3D and closer, that means tasks performed closer than 33 cm) after a concentrated near-work task in 30 to 40-year-olds.^{ZEISS Study 2} Finally the day arrives when a lens wearer cannot comfortably sustain accommodation over a range of close distances, and progressive addition lenses are required.

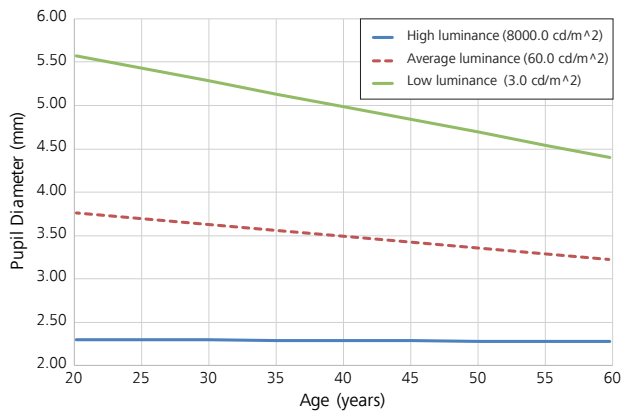

Figure 3 Pupil diameter as a function of age after Watson and Yellot, 2012.

But accommodation is not the only visual response that changes with age. The pupil responds to light by constricting; this is called the “pupillary light reflex.” However, it constricts from a base diameter established by its ability to dilate.

The pupil dilation response decreases with age and causes the average pupil size to decrease. Figure 3 shows one set of data for three levels of illumination according to Watson and Yellot.^[11] Changes of pupil size affect retinal illuminance and depth of focus; both of those in turn affect acuity. Furthermore, pupil diameter is important when calculating the magnitude of aberrations in spectacle lenses. This means that age-related changes in pupil size can significantly affect the utility of spectacle lenses. All of these changes to accommodation and pupil diameter must be considered when evaluating and responding to the changing demands of dynamic connectivity. This is the role of ZEISS SmartView Technology.



ZEISS SmartView Technology: Responding to a Changing World and Changing Eyes

All ZEISS SmartLife Lenses reflect the ZEISS heritage of excellence in optics, comprising four pillars: Clear Optics, Thin Optics, Smart Dynamic Optics and Age Intelligence. Clear Optics is ZEISS’ commitment to precision in every step of lens design

and fabrication. Thin Optics provides improved aesthetics by achieving the best balance between aesthetics and optics. Two new capabilities provide a novel approach to lens design.

Smart Dynamic Optics is a response to changes in the visual environment and ergonomic challenges posed by dynamic connectivity, while Age Intelligence adapts lens designs to changes in vision as wearers age. These approaches are informed by a deep understanding of the visual problems presented by dynamic connectivity. Together ZEISS calls them ZEISS SmartView Technology.

Optics Corrected for Pupil Size According to Age

One step in the creation of ZEISS SmartLife Lenses is to account for the change in pupil size according to the wearer’s age, using ZEISS Luminance Design Technology 2.0.^[12] This lens design method, pioneered by ZEISS, improved lenses by calculating dioptric powers using the entire beam of light passing through the pupil instead of using a chief ray without considering the real pupil diameter. In previous ZEISS lenses incorporating ZEISS Luminance Design Technology, the pupil size was fixed for all lenses according to the design principle. For example, ZEISS Progressive Individual 2 lenses are calculated for a fixed pupil size determined by analysis to represent average pupil size over a wide range of light conditions, while ZEISS DriveSafe lenses are calculated for a pupil size based on low light conditions only. To learn more about these technologies, please refer to the ZEISS Luminance Design Technology White Paper (2019).

In ZEISS SmartLife Lenses, the assumed pupil size is determined by the wearer’s age. Age may be transmitted with an order, otherwise add power will be used to define the wearer’s age. From the age, an age-appropriate pupil size is calculated. This pupil size is then used as reference pupil size in the optimization of the prescription surface that establishes the prescription surface to be produced on the lens. This approach is used for all ZEISS SmartLife Single Vision / Digital / Progressive Lenses.

Only ZEISS SmartLife Lenses with Age Intelligence provide a single, integrated approach for managing the effect of pupil size to achieve the best visual performance for any type of lens and for wearers of any age. The management of pupil size during lens calculations further interacts with the targeted distribution of lens powers and viewing distances established by a new object-space model.

Optics Corrected for Dynamic Accommodation

The advent of digital devices and the ensuing connected lifestyle have changed the way people use their eyes. As previously mentioned, studies have shown that people are focusing at closer distances. Furthermore, ZEISS researchers have found that they are looking at lower gaze angles. ZEISS SmartLife Lenses introduce a new, unified approach to define the binocular viewing distance according to vertical gaze angle.

The designs of ZEISS SmartLife Single Vision, Digital and Progressive Lenses incorporate distributions of dioptric power optimized for the requirements of a wearer according to the prescribed addition. Age Intelligence provides guidance for the accommodative-convergence capabilities of wearers as they grow older and progress from single vision to multifocal lenses. Smart Dynamic Optics defines the relationship between gaze angle and object distance. Together they provide ZEISS with a new object-space model of the relationship between vertical gaze angle, binocular viewing distance and values of dioptric mean power for each lens type and prescribed addition power. Figure 4 shows the relationship between vertical gaze angle and viewing distance used to create the three classes of ZEISS SmartLife Lenses.

To understand how this new model works, it is necessary to consider how it is applied for each type of lens, taking into account the facts previously discussed in this paper.

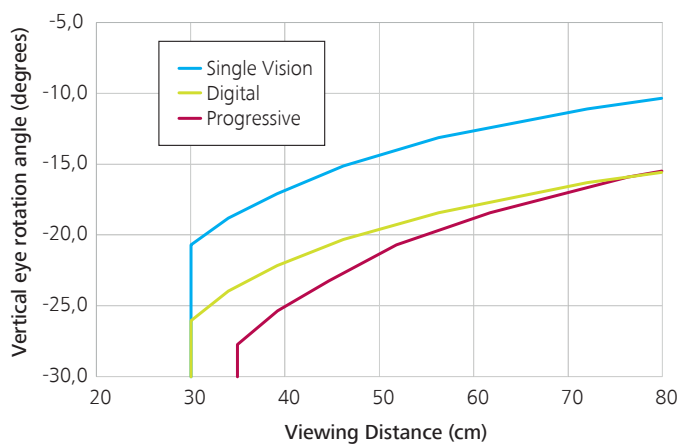

Figure 4 The relation between viewing distance and vertical eye rotation angle for single vision, digital, and progressive lenses. These curves are for average frames with standard corridor length. The new ZEISS object space model takes into account the requirements of dynamic connectivity and age

Single vision lens wearers not only have a large amplitude of accommodation, their accommodation and dis-accommodation responses are rapid. Furthermore, in the typical head-down and eye-down posture used for handheld devices, accommodative amplitude in young people is enhanced. The young single vision lens wearer therefore does not need any addition power, and the object space model assumes full accommodation to the object space dioptric demand.

On the other hand, the significant downward eye rotation angle and very close viewing distance require a different lens surface shape in the lower lens than the optimum shape for large horizontal eye movements along the horizon in the upper lens region. ZEISS SmartLife Single Vision Lenses use the object space model to calculate an individually designed freeform surface according to the position of wear that minimizes oblique astigmatic errors for all viewing distances over the entire range of the object space model. The change in viewing distance proceeds

smoothly from infinity when viewing straight ahead to 30 cm at a 20 degree downward gaze angle. Figure 5 shows a significant improvement in the clarity of visual fields of ZEISS SmartLife Single Vision Lenses compared to standard single vision designs. A complete analysis of ZEISS SmartLife Single Vision Lenses over a range of prescriptions and viewing distances revealed improved optical performance with up to 88% larger clear fields of view.^[13] ZEISS SmartLife Digital Lenses also have been improved using the new object space model. In contrast to ZEISS SmartLife Single Vision Lenses, the model for ZEISS SmartLife Digital Lenses transitions to closer distances starting at a lower point on the lens. This is necessary to avoid interference with far vision for people who are accustomed to single vision lenses or no lenses at all. At 15 degrees downgaze a very small increment of addition power is set for viewing at 80 cm; by 25 degrees downgaze the addition power has reached its full value and the model viewing distance has zoomed in to 30 cm, the same as for ZEISS SmartLife Single Vision Lenses. This new design approach reduces overall blur levels compared to previous ZEISS digital lenses.^[14] ZEISS SmartLife Digital Lenses may be ordered by the eyecare professional with addition powers between +0,50 and +1,25 diopters. By the time a person is presbyopic, it is no longer possible to sustain accommodation for the closest viewing distances, and comfortable viewing of intermediate range objects is also compromised by an amount that depends on age. Although the new ZEISS object space model for ZEISS SmartLife Digital and Progressive Lenses is set to about 80 cm at 15 degrees downgaze, the specifications are different at closer viewing ranges. This is because progressive wearers require a wide intermediate visual field. A progressive lens with a corridor that is too short would be unusable at 50 to 80 cm, so SmartLife Progressive Lenses are optionally available with variable corridor lengths.

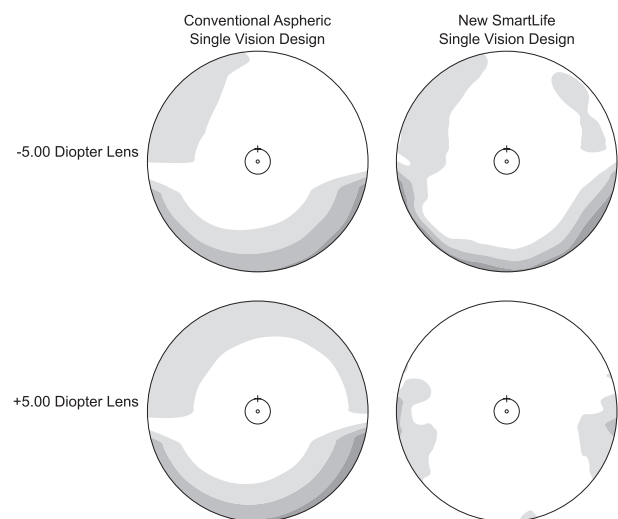

Figure 5 ZEISS SmartLife Single Vision Lenses achieve clearer vision by reducing oblique astigmatism errors throughout the lens

PAL Wearer

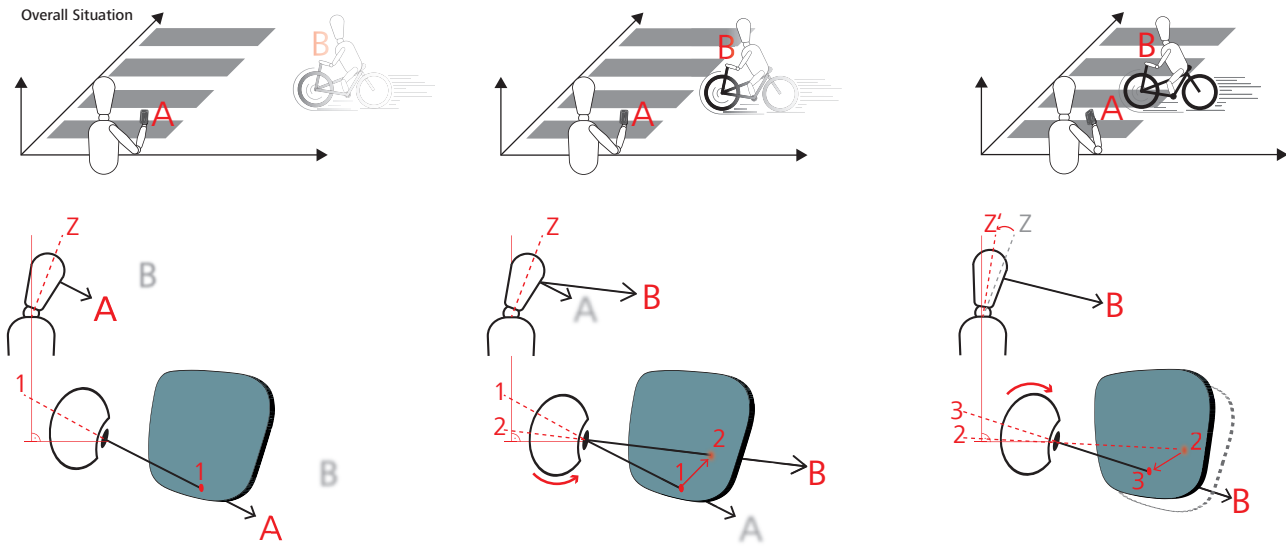

Figure 6 Changes of attention result in new visual scanning patterns across lenses

While ZEISS SmartLife Single Vision and Digital Lenses are designed for a closest viewing distance of 30 cm, ZEISS SmartLife Progressive Lenses are designed for a closest viewing distance of 35 cm. This is to allow the prescribed addition power to function better over a wider range of close viewing distances.

Three types of lens traditionally treated separately are defined with a unified approach in ZEISS SmartLife. ZEISS SmartView Technology establishes the requirements of the new object-space model. Smart Dynamic Optics provides the new relationship between viewing distance and gaze angles for today's connected lifestyle. Age Intelligence establishes the new relationship between viewing distance and the prescribed addition power. Only ZEISS SmartLife Lenses provide a single, integrated approach for managing the dynamic relationships between vertical viewing angles and viewing distance in single vision, digital and progressive lenses.

Optics Designed for New Visual Patterns

Today people are using connected devices for many activities and as we have seen, more areas of the lens are used for visual fixations. This is important in single vision lenses and even more important in multifocal lenses.

In single vision lenses, the prescription requirement is constant for all gaze angles. ZEISS SmartLife Single Vision Lenses use the object space model to minimize oblique astigmatism when wearers look down to view a close, handheld device and when they look up to view more distant objects. The optimization of the design is achieved to make the change as smooth and imperceptible as possible.

In digital and progressive lenses, the situation is quite different. As eyecare professionals are aware, all lenses having variable distributions of addition power also have peripheral power errors. These peripheral areas include astigmatic errors and also values of mean power that do not match all possible viewing distances. When an object of interest presents itself to peripheral vision of a person viewing a handheld device, the resulting eye movements may follow a path with dioptric powers that are noticeable to the wearer.

Figure 6 shows an example. Consider a pedestrian who is looking down on a smartphone while walking on a city sidewalk. His attention is fixed on the smartphone ("A") but as he walks, a bicyclist ("B") approaches from the right a few meters away, which he notices with his peripheral vision. Automatically he turns his eyes to view the cyclist, shifting gaze from point 1 on the lens to a point 2. A moment later he lifts his head and continues to follow the cyclist with his eyes for a moment. This sweeps the line of sight along the path from point 2 to point 3. Along this viewing path the addition power and astigmatism aberration of a

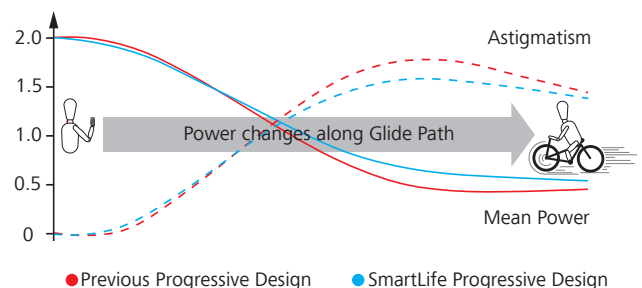

Figure 7 ZEISS SmartLife Digital and Progressive Lenses Use flatter and smoother power distributions

multifocal lens are continuously changing. Each person and every circumstance will require a different path as the eyes fixate on new targets, like the glidepath of a plane coming in for a landing. Each glidepath eventually leads back lower in the lens as our device makes a new demand for our attention. This places a burden on lens designers to ensure that the distribution of dioptric powers throughout the region of refixations is managed correctly.

ZEISS realized that the pattern of eye movements in a connected lifestyle would require changing the optical design of its digital and progressive lenses. Because dynamic connectivity leads to spectacle lenses being used for complex and dynamic activities, the new distributions of power are smoother and flatter. Figure 7 shows an example of the smoother visual glidepath in a SmartLife Progressive Lens compared to its predecessor.

In comparison to ZEISS Precision lenses, ZEISS SmartLife Progressive Lenses have smoother transitions into areas of peripheral blur with a lower level of blur for intermediate and near distances.^[15] In a very demanding study of transient target detection in the periphery of ZEISS SmartLife Progressives ^{ZEISS Study 3}, the enhanced peripheral optics allowed very high levels of performance among the most perceptive wearers.^[16]

A Realignment of Design Goals

ZEISS SmartView Technology is a realignment of design goals to keep up with the fast pace of changing lifestyles. Smart Dynamic Optics acknowledges and reconsiders the environmental and ergonomic challenges presented by dynamic connectivity. Age Intelligence applies ZEISS research and experience to the differing characteristics and abilities of adults of all ages, whether they wear single vision, digital or progressive lenses. Taken together, ZEISS SmartLife Lenses are the first comprehensive application of lens design to a continuous range of lenses meant for adults of any age in an era of dynamic connectivity.

ZEISS SmartLife: Lenses for a Lifetime

ZEISS SmartLife Lenses are being introduced so that all spectacle wearers may be treated the same way because the new dynamic connected lifestyle affects everyone. In an external acceptance study among participants who live a connected lifestyle, ZEISS SmartLife Lenses gave 84% of single vision, digital and progressive lens wearers all day visual comfort.^{ZEISS Study 4} In this study, 94%

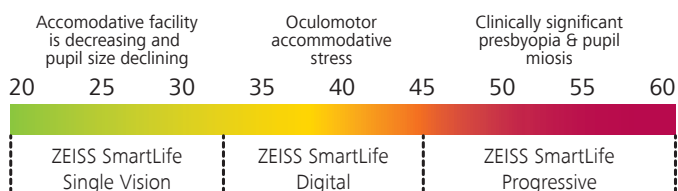

Figure 8 ZEISS SmartLife Lenses are designed for adults whose lens requirements change over time

of ZEISS SmartLife Single Vision wearers perceived wide fields of comfortable vision for intermediate and near vision tasks. 73% of SmartLife Digital Lens wearers reported feeling no strain at the end of the day and the majority reported feeling less eyestrain compared to their habitual lenses. Four out of five ZEISS SmartLife Progressive wearers experienced smooth vision from near to far across all viewing zones. The results of this study confirm that ZEISS SmartLife Lenses provide outstanding performance for wearers age 20 and older.

Although ZEISS provides general guidance for the use of ZEISS SmartLife Lenses, ZEISS believes that eyecare professionals are best able to judge when it is time for any individual person to make the next step in lens type. ZEISS SmartLife Lenses adapt to the life stories of wearers.

Figure 8 illustrates a life timeline that might be applied to any individual. In early years a person may or may not have a significant need for vision correction. In this example, the individual we will call Alexandra has significant ametropia. From the beginning she will enjoy ZEISS SmartLife Single Vision Lenses. As each year goes by, Alexandra’s pupil will shrink and her accommodative facility may decline, until a time when the stresses of dynamic connectivity cause symptoms that the eyecare professional will recognize. In Alexandra’s case, it happens at age 35, when she would benefit from ZEISS SmartLife Digital Lenses having an addition determined by the eyecare professional between +0.50 and +1.25 diopters. Finally, the day will come, perhaps age 45, when Alexandra needs the full-range correction provided by ZEISS SmartLife Progressive Lenses. Alexandra is a unique individual, and other people will follow different paths.

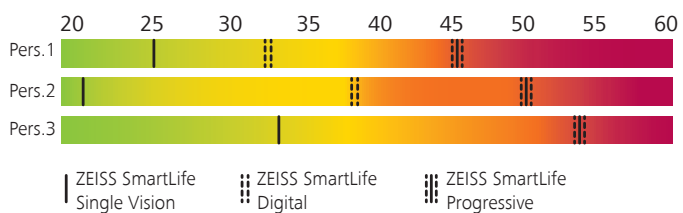

Figure 9 ZEISS SmartLife Lenses will adapt to the visual history of wearers as they age

Figure 9 represents a few of the possible stories of other people who will benefit from ZEISS SmartLife Lenses.

Only an eyecare professional can determine which type of lens is appropriate for a specific patient of a particular age and the amount of addition power (if any). Some people will not proceed through all lens types. For a person without ametropia, ZEISS SmartLife Digital or Progressive Lenses may be used as their first pair of eyeglasses. Some single vision wearers may suddenly into presbyopia that they skip digital lenses entirely. But as the demands of dynamic connectivity continue to grow, it is ever more likely that many wearers will progress through all three lens types.

Conclusion

ZEISS SmartLife Lenses are based on four design principles that combine to fulfill the requirements of a dynamic, connected lifestyle for adults of all ages. Clear Optics provides precision in every step of lens design and fabrication; Thin Optics improves aesthetics by achieving the best in thin and light lenses. Together ZEISS Smart Dynamic Optics and Age Intelligence establish a new technology platform called ZEISS SmartView. These new technologies provide a new object space model that accounts for today's visual dynamics while providing smoother distribution of powers to improve vision during eye movements that cover a larger area of the lens. Each ZEISS SmartLife Lens is designed according to the accommodative status and pupil size according to the wearer's age. The result is that eyecare professionals now may choose ZEISS SmartLife Lenses as a single solution for all of today's active, connected adults.

ZEISS Studies

- ZEISS Study 1** *Dynamic gaze study - Changes in gaze behavior through digital devices. ZEISS Vision Science Lab, Institute for Ophthalmic Research, University of Tuebingen, 2019. Data on file.*
- ZEISS Study 2** *External performance test on ocular accommodation comparing ZEISS SmartLife Digital Lenses with ZEISS single vision lenses. Aston Optometry School, Aston University, UK, 2019. Data on file.*
- ZEISS Study 3** *Performance test on ZEISS SmartLife Progressive Lenses. ZEISS Vision Science Lab, Institute for Ophthalmic Research, University of Tuebingen, 2019. Data on file.*
- ZEISS Study 4** *External consumer acceptance test on the ZEISS SmartLife Lens portfolio. Aston Optometry School, Aston University, UK, 2019. Data on file.*

References

- [1] Deloitte LLP. (2016). *There is no place like phone. Global Mobile Consumer Survey 2016: UK cut.*
- [2] Deloitte LLP. (2017). *State of the smart - Consumer and business usage patterns. Global Mobile Consumer Survey 2017: UK Cut.*
- [3] Bababekova Y., Rosenfield M., Hue J.E., Huang R. R. (2011). *Font Size and Viewing Distance of Handheld Smart Phones. Optometry and Vision Science, 88:795-97.*
- [4] Ioannidou F., Hermens F., Hodgson, T.L. (2017). *Mind your step: the effects of mobile phone use on gaze behaviour in stair climbing. Journal of Technical and Behavioural Science, 2: 109-120.*
- [5] Timmis M.A., Bijl H., Turner K., Baevitch I., Taylor MJD, van Paridon K.N. (2017). *The impact of mobile phone use on where we look and how we walk when negotiating floor base obstacles. Plos One, 12(6):e0179802.*
- [6] Gustafsson E., Thomé S., Grimby-Ekman A., Hagberg M. (2017). *Texting on mobile phones and musculoskeletal disorders in young adults: A five-year cohort study. Applied Ergonomics, 58:208-214.*
- [7] Adapted from Duane A. (1922). *Studies in monocular and binocular accommodation with their clinical implications. Am J Ophthalmol Series 3, 5:865-877.*
- [8] Kasthurirangan S., Vilupuru A.S., Glasser A. (2003). *Amplitude dependent accommodative dynamics in humans. Vision Research, 43:2945-2956.*
- [9] Atchison D.A., Claydon C.A., Irwin S.E. (1994). *Amplitude of Accommodation for Different Head Positions and Different Directions of Eye Gaze. Optometry and Vision Science, 71:339-345.*
- [10] Ciuffreda K.J. (2006). *Accommodation, the Pupil and Presbyopia. In William J. Benjamin (Ed.) Borish's Clinical Refraction (pp. 134-136). St. Louis, MO: Butterworth Heinemann Elsevier.*
- [11] Watson A.B., Yellot J.I. (2012). *A Unified Formula for Light-Adapted Pupil Size. Journal of Vision, 12(12): 1-16.*
- [12] ZEISS LuminanceDesign Technology. *White Paper (2019) Doc Nr: EN_20_500_00011).*
- [13] *Raytraced binocular visual fields calculated for blur below an RMSPE threshold over a prescription power range from -10,0D to +8,0D. Analyses by Technology & Innovation, ZEISS Vision Care, DE, 2019.*
- [14] *Analysis of average blur changes for peripheral vision on objects placed according to object model for different object distances considering blur above just noticeable RMSPE blur threshold for ZEISS SmartLife Digital Lenses versus ZEISS Digital Lenses. Analyses by Technology & Innovation, ZEISS Vision Care, DE, 2019.*
- [15] *Analysis of lateral RMSPE blur changes for peripheral vision of objects placed according to object model for different object distances considering blur above just noticeable RMSPE blur for plano/-3,0/+3,0D ADD 2,0D ZEISS SmartLife Progressive Lenses versus ZEISS Precision Progressive Lenses. Analyses by Technology & Innovation, ZEISS Vision Care, DE, 2019.*
- [16] *Two alternative forced choice identification of a 300 millisecond presentation of Gabor patches (spatially filtered circular area of sinusoidal pattern) of several spatial frequencies and contrasts compared to a reference presentation in the contralateral periphery while wearing ZEISS SmartLife Progressive lenses, n=17. ZEISS Vision Science Lab, Institute for Ophthalmic Research, University of Tuebingen, 2019.*

Carl Zeiss Vision Inc.

USA 1-866-596-5467

www.zeiss.com/lenses



Seeing beyond