

CUBE Modular Cabinets

Flexible Multiple Bay Cabinets Allow for Field Expansion with Placement of Additional Bays

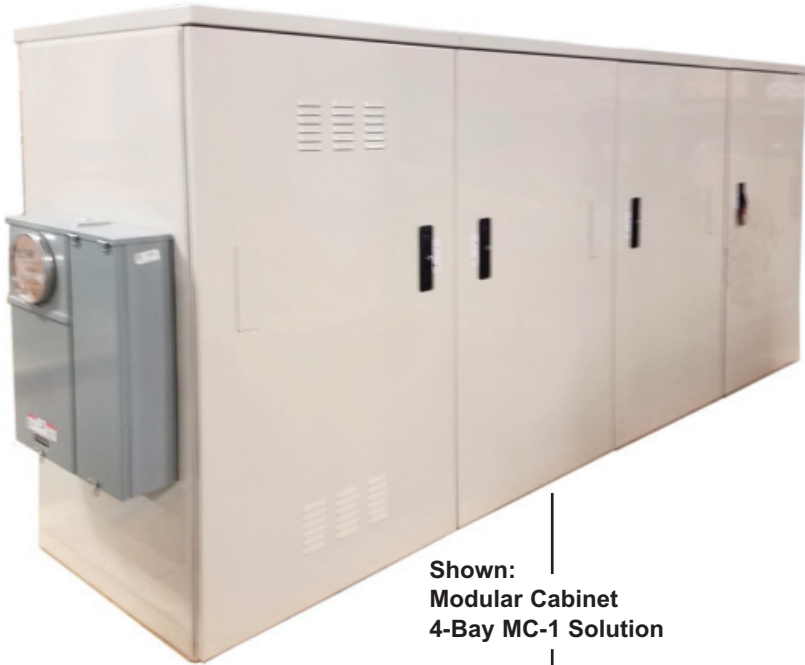

Shown:
Modular Cabinet
4-Bay MC-1 Solution

Charles Modular Cabinets offer the ultimate in flexibility for outdoor enclosure deployments. Multiple standard bays can be mixed and matched into a multitude of different configurations to suit a specific application. The cabinet lineup can be built and shipped direct from the Charles factory in the desired configuration. Additional bays can be ordered separately at a later date to be added in the field to accommodate growth. Standard bay types include relay rack bays to support power and active electronics, passive fiber management, and battery bays to support multiple strings of 12V Monoblock batteries. Options include different thermal management systems for bays needing cooling, internal or external AC power panels, integrated AC-DC power systems, fiber panels, and plinths. Thermal management systems are door mounted and can be added / changed out in the future as cooling needs change.

Modular Cabinets are available in three different sizes (size per bay):

MC-1 (small)	62"H x 32"W x 32"D	31RU Equipment Space (front/back)
MC-2 (medium)	72"H x 32"W x 36"D	39RU Equipment Space (front/back)
MC-3 (large)	84"H x 32"W x 36"D	44RU Equipment Space (front/back)

Specifications:

Construction	0.125" Aluminum Welded Construction Outer Enclosure, Powder Coated Cool White Finish,
Mounting Style	Pad Mount



Shown: Modular Cabinet 2-Bay MC-1 Solution



CUBE Modular Cabinets

MODULAR CABINET PART NUMBER CONFIGURATOR

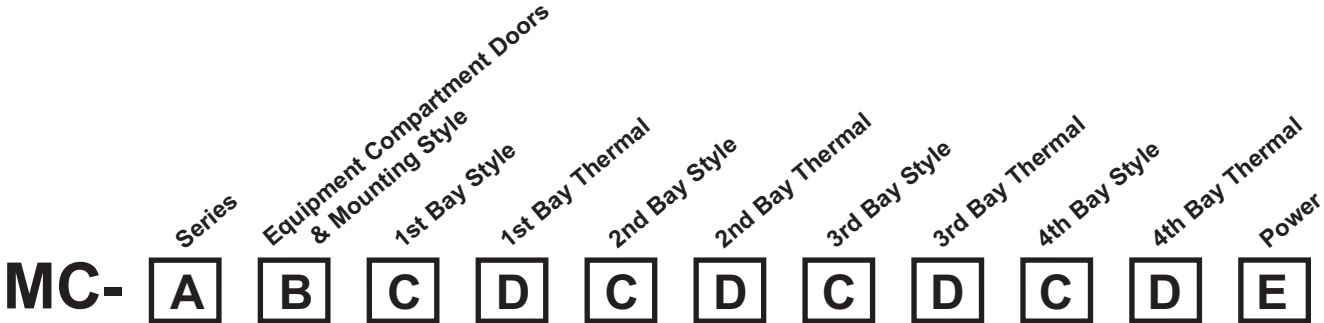

For Values A through E, choose desired option from corresponding column below.

A

Series

- 1 - 62"H x 32"W x 32"D
- 2 - 74"H x 32"W x 36"D
- 3 - 84"H x 32"W x 36"D

B

Equip Compartment Doors & Mounting Style

- 2 - Front and Rear Door
- 5 - Front Door, Rear Panel

C

Bay Style

- B - Modular Battery Bay
- E - Modular Equipment Bay
- F - Modular Passive Fiber
- N - None

D

Bay Thermal

- 4 - 6000W CTMS
- 5 - 3500W CTMS
- G - Vented Only
- H - Vented w/ Fan
- J - 4000 BTU HVAC 120VAC
- K - 4000 BTU DC HVAC
- L - 10000 BTU DC HVAC
- M - 1880W HX
- N - None
- T - 3500W 48VDC HX
- U - 10000 BTU HVAC, 240VAC
- V - (2) 10000 BTU DC HVAC
- Y - (2) 10K BTU AC Powered HVAC

E

Power

- K - 16 Position AC Load Center
- N - No Power
- P - AC, 20 Position
- T - AC, 30 Position

Sample Part Number:

MC-12B B J B E J F N K

Modular Cabinet, Small (62"H x 32"W x 32"D), Front and Rear Doors, 16 Position AC Load Center

- 1st Bay: Modular Battery Bay with 4000 BTU HVAC 120VAC
- 2nd Bay: Modular Battery Bay with 4000 BTU HVAC 120VAC
- 3rd Bay: Modular Equipment Bay with 4000 BTU HVAC 120VAC
- 4th Bay: Modular Passive Fiber with no power

CUBE Modular Cabinets

MODULAR CABINET DIMENSIONAL VIEWS

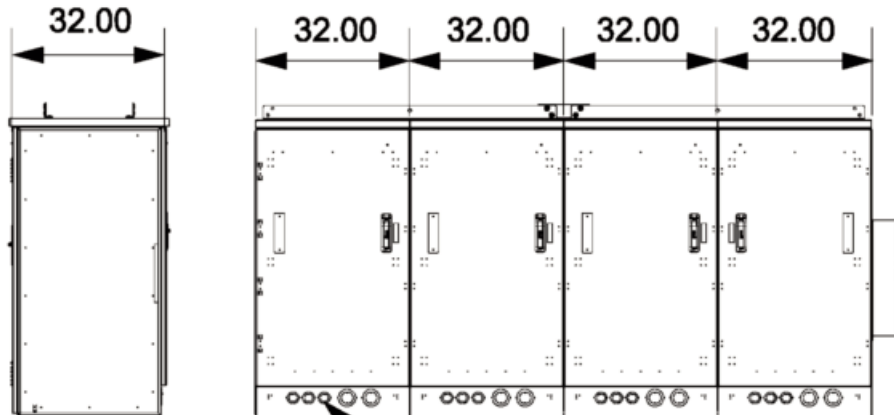
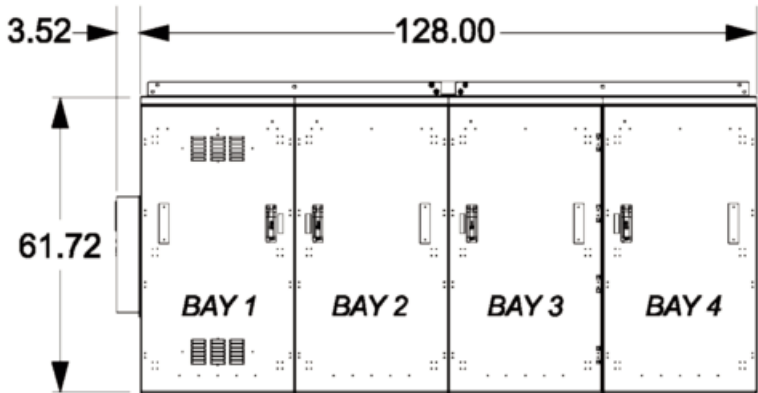
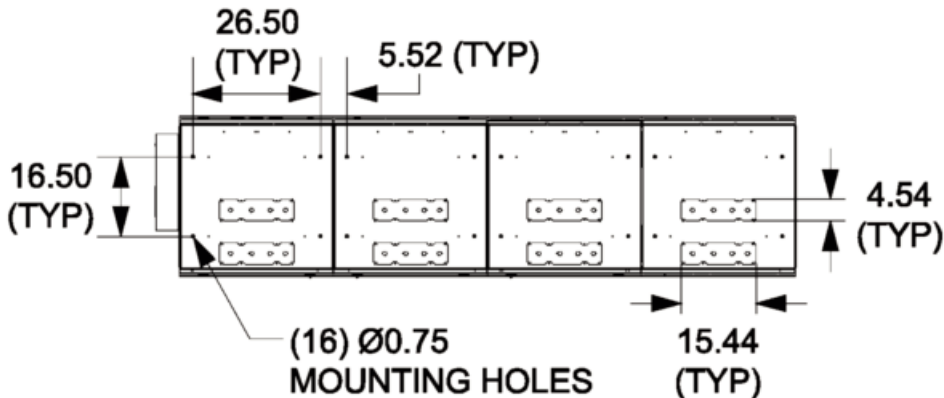
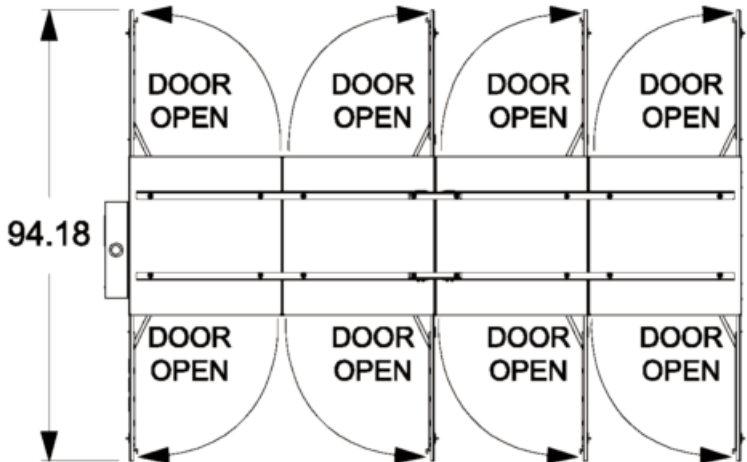

(3) Ø1.75/2.50 KNOCKOUTS
 (2) Ø2.50/3.60 KNOCKOUTS
 (PER BAY)