



From February 1st, 2017 SAMES Technologies SAS becomes SAMES KREMLIN SAS  
A partir du 1/02/17, SAMES Technologies SAS devient SAMES KREMLIN SAS

**SAMES**  **KREMLIN**



# User manual

**e-Jet2 equipments,  
Nondestructive testing and  
complex powder versions**



All communication or reproduction of this document, in any form whatsoever and all use or communication of its contents are forbidden without express written authorisation from SAMES Technologies.

The descriptions and characteristics mentioned in this document are subject to change without prior notice.

© SAMES Technologies 2015



**WARNING :** SAS Sames Technologies is registered with the Ministry of Labour as a training institution.

Throughout the year, our company offers training courses in the operation and maintenance of your equipment.

A catalogue is available on request. Choose from a wide range of courses to acquire the skills or knowledge that is required to match your production requirements and objectives.

Our training courses can be delivered at your site or in the training centre at our Meylan head office.

SAS Sames Technologies operating manuals are written in French and translated into English, German, Spanish, Italian and Portuguese.

The French version is deemed the official text and Sames will not be liable for the translations into other languages.

---

Index revision : A

2

6433

---



e-Jet2 equipments,  
 Nondestructive testing and  
 complex powder versions

1. Safety Regulations - - - - -	4
2. Description - - - - -	5
2.1. <i>General presentation</i> . . . . .	5
2.2. <i>Control panel presentation</i> . . . . .	6
3. Characteristics - - - - -	7
3.1. <i>General characteristics</i> . . . . .	7
3.2. <i>Pneumatic characteristics</i> . . . . .	7
4. Operation - - - - -	8
5. Tools - - - - -	8
6. Installation - - - - -	9
6.1. <i>Connections</i> . . . . .	13
6.2. <i>Connection of "Mach-Jet Gun" and mains plug</i> . . . . .	14
7. Using the equipment "eJet2" - - - - -	15
7.1. <i>Main rules</i> . . . . .	15
7.1.1. <i>In Nondestructive testing version.</i> . . . . .	15
7.1.2. <i>In powdering version</i> . . . . .	15
8. Maintenance- - - - -	16
8.1. <i>Cleaning</i> . . . . .	16
8.2. <i>Cleaning of the check valve fitted on the injection air supply</i> .	16
8.3. <i>Dump of tank</i> . . . . .	16
8.3.1. <i>Procedure 1</i> . . . . .	16
8.3.2. <i>Procedure 2</i> . . . . .	16
9. Spare parts- - - - -	17
9.1. <i>"e-Jet2" equipment, nondestructive testing version</i> . . . . .	17
9.1.1. <i>Cart</i> . . . . .	19
9.1.2. <i>Hoses.</i> . . . . .	23
9.1.3. <i>Options for use in powdering version.</i> . . . . .	23



## 1. Safety Regulations



**WARNING :** This document contains links to the following user manuals:

- [see RT Nr 6431](#) for the CSV 230 tank.
- [see RT Nr 6336](#) for the “Mach-Jet” spray gun and “CRN 457” control module.



**WARNING :** The “e-Jet2” cart is designed to equip nondestructive testing equipments, powder developer product or powder paint.

This device may be dangerous if it is not used in compliance with the safety regulations specified in this manual.

**Operating temperature range: From 0 °C to 40 °C (32 °F to 104 °F).**

- The “e-Jet2” cart and the CSV 230 tank must always be installed and used in areas where there is no risk of explosion.
- It is essential to connect the ground thimble on the cart to the ground system thimble of the powder-coating installation (or powder-coating booth) to guarantee the safety of operators and correct operation of the powder-coating equipment.
- All powder filling operations of tank must be carried out in a ventilated area designed for the purpose. **It is imperative to switch off the air supplies during the phases of filling or dump of the tank.**
- The hose of fluidization air also take part to connect the tank to the ground.
- If the tank is used away from the cart, it is essential to connect the tank to the ground system electrically.
- Under no circumstances may the cart be used to carry or transport loads other than the powder tank.
- Skin-contact or inhalation of products used with this equipment may be dangerous for personnel (cf.: Safety sheets for products used).

## 2. Description

### 2.1. General presentation

This equipment is designed for a Nondestructive Testing configuration. It can be however used with special or complex powders to be fluidised using optional components.

With its compact size, the cart of the equipment "e-Jet2" remains very stable and easy to transport in all circumstances thanks to its gravity center lowered, to its large back wheels and its two front directional wheels.

The equipment "e-Jet2" includes the CRN 457 control module with ideal height and tilted in a optimized way for the greatest comfort of the operator. The swivelling of the screen on the operator side is done easily thanks to the directional wheels of the cart.

The Mach-Jet gun can be hung with good height, on the two sides of the cart.

Provided with many fast couplings of air, its use and its maintenance are optimized compared to the previous generations.

Finally, numerous arrangements are planned for the various phases of use of the equipment.

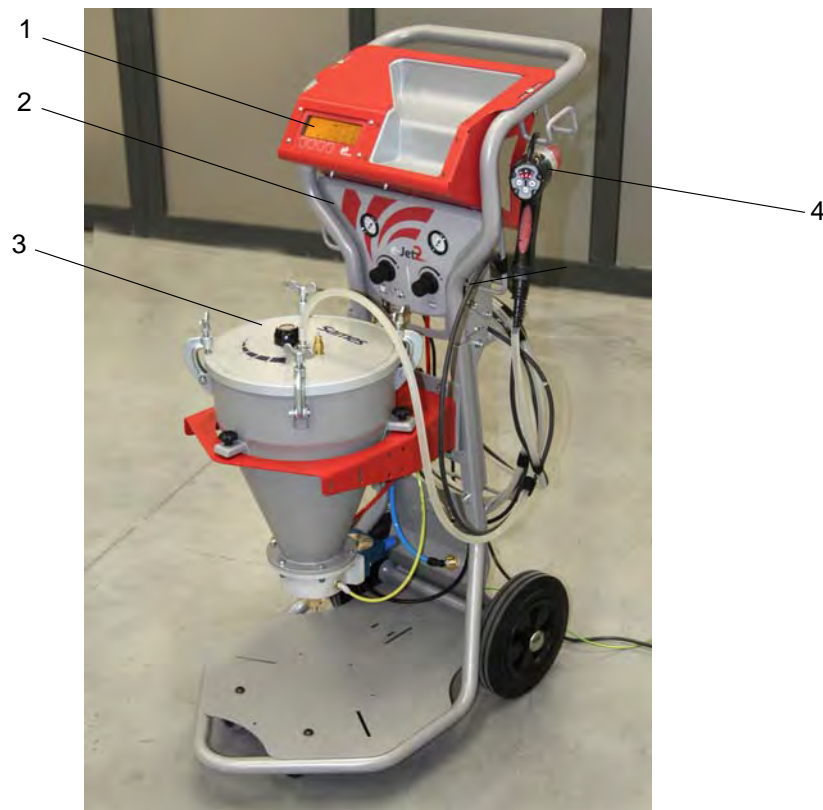

Equipment with tank	
1	CRN 457 control module
2	Control panel
3	Tank
4	"Mach-Jet" spray gun

## 2.2. Control panel presentation



Reference	Function
1	Vibrator supply pressure adjustment and reading
2	Fluidization pressure adjustment and reading

### 3. Characteristics

#### 3.1. General characteristics

The cart structure is designed to support:

- A tank with a capacity of approximately 15 litres of fluidised powder (i.e useful volume: 9.2 liters).

"e-Jet2" cart dimensions (HxLxW)	1,220 x 480 x 770 mm
Approximate weight (without powder)	48 kg.

#### 3.2. Pneumatic characteristics

Characteristics of the compressed-air supply according to standard NF ISO 8573-1:

Maximum dew point at 6 bar (90 psi)	Class 4, i.e. +3°C (38°F)
Maximum particle-size of solid pollutants	Class 3, i.e. 5 µm.
Maximum oil concentration	Class 1, i.e. 0.01 mg/m <sub>0</sub> <sup>3</sup> *
Maximum concentration of solid pollutants	Class 3, i.e. 5 mg/m <sub>0</sub> <sup>3</sup> *

\* : Air flow rate values are given for a temperature of 20°C (68 °F) at atmospheric pressure of 1,013 mbar.

The filter installed on the "e-Jet2" cart is used to ensure correct operation of the equipment in the case of accidental non-compliance with compressed-air filtering recommendations.

"e-Jet2" equipment air-supply pressure	7 bar +/- 1 bar (*)
--	---------------------



**WARNING :** (\*) Pressure in excess of 8 bar may cause operating malfunctions.

#### Consumption of the equipment

Nondestructive testing version	Injection1 to 12	between 160 and 220NI/min
Powdering version	Injection adjusted to 6 and shutter adjusting	190NI/min

#### 4. Operation

The powder contained in the tank is vibrated then fluidised by an upward flow of air, distributed evenly by a porous cone located at the bottom of the tank.

The powder is taken, measured then sucked up by the injector and evacuated thanks to the present pressure in the tank.

The injection and fluidisation airs add up and serve as air of transport in the powder hose.

The shutter situated on the lid of the tank allows to fill the passage of the powder in a partial or total way (separation air and powder) to regulate mechanically the flow. The pressure of injection and the position of the shutter serve to optimize the desired flow of powder.



**WARNING :** The maximal height of filling of the tank never has to exceed the ejector.

#### 5. Tools

No specific tools.



## 6. Installation

The cart is made in two parts, a base plate and a high structure.

- **Step 1:** Install the structure on the base plate while having previously removed the two screws, washers and nuts located on the base plate.



Step 1

- **Step 2:** Install the tank fastening assemblies A, B and C ([see § 9.1.1 page 19](#)).
- **Step 3:** Maintain these parts using the two screws, washers and nuts. Sufficiently tighten without deforming the tubular elements.

Steps 2 and 3

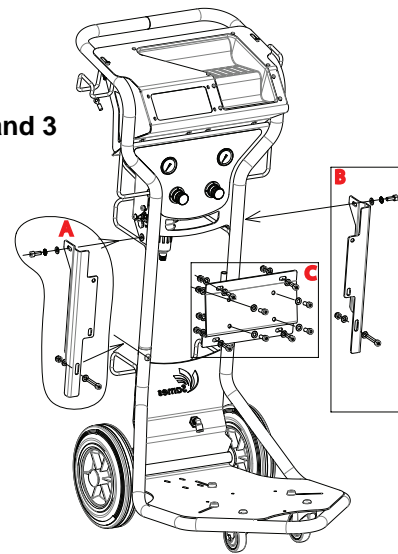

DES06251

- **Step 4:** Connect the main air supply hose to the filter while passing it previously into the guide tube. Into the second guide tube, pass the tank fluidization air hose (black anti-static), and connect it to the regulator corresponding. Then, connect the yellow hose (fluidization air) equipped with the restrictor (restrictor side outlet of the regulator) and connect it to the output of the second regulator.

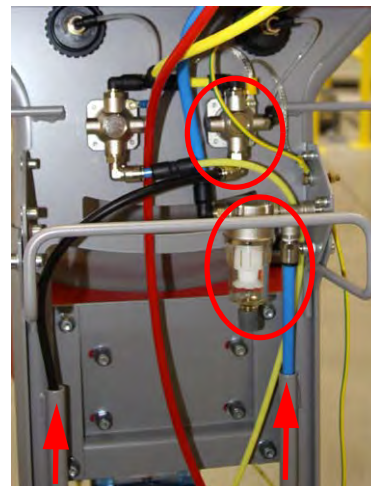

Step 4

- **Step 5:** Secure the **CRN 457** control module on the cart.  
Center the screen of the module to the access window et screw the module by its front face using the four selftapping screws. The module must be flushed.



**Nota: The security and the remaining into position of the module are done using the four screws, washers and 1/4 turn nut and an allen wrench.**

Equip previously the four provided screws with washers and 1/4 turn nut (attention: 1/4 turn thread nut must be fitted flushed and in the direction indicated to ensure its function; a locating device on the cart allows to check if the directory of nut fitting has to be respected).



Put in place the 1/4 turn nut on the screw in the grooves of the CRN 457 box, the flat washers being placed outside,



and move the screw at the level of the most narrow part of the print .  
Tighten strongly using an allen wrench.



Check visually that the 1/4 turn nut is placed perpendicular to the groove of the CRN 457.



- **Step 6:** Connect the 220V main power cable to the back of the CRN457 (1) ([see § 6.2 page 14](#)).  
Connect the CRN457 to the ground on its ground screw via the ground thimble (2).
- **Step 7:** Connect the main pneumatic supply union of the CRN457 (3).  
Connect the yellow hose to the pneumatic output auxiliary (4) which supplies the regulators.
- **Step 8:** Closed the dilution outlet of the CRN 457 with a plug (P/N # F6RLZX396) (5).
- **Step 9:** Connect the red hose (air injection supply) (6).
- **Step 10:** Connect the Mach-jet spray gun (7).

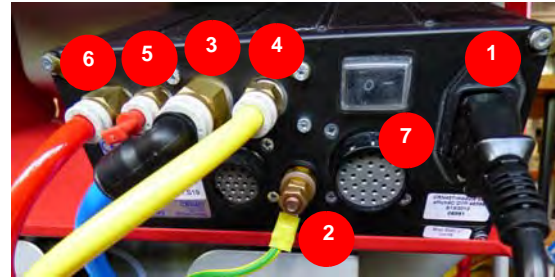

- **Step 11:** Fasten the tank support on the cart using the four M8 x20 screws. Place the tank on the elastic studs, vibrator side cart frame, and secure with the knurled nuts.

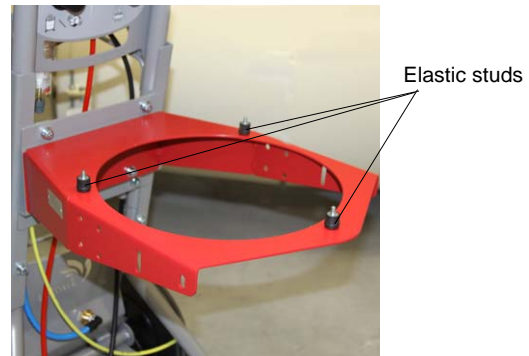

- **Step 12:** Connect the air supplies and the ground wire on the tank:
  - Red hose: Injection air (1).
  - Yellow hose: Fluidising air (2)
  - Black hose: Vibrator air (3)
  - Green / Yellow cable: ground (4).

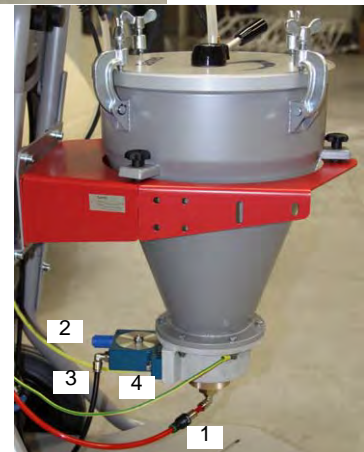

- **Step 13:** Connect the ground cable (length: 5m) to the grounding screw located on the side of the cart. The other end of the ground cable has to be imperatively connected to a part of the booth electrically connected to the ground. and connect the ground cable of the tank.



## 6.1. Connections

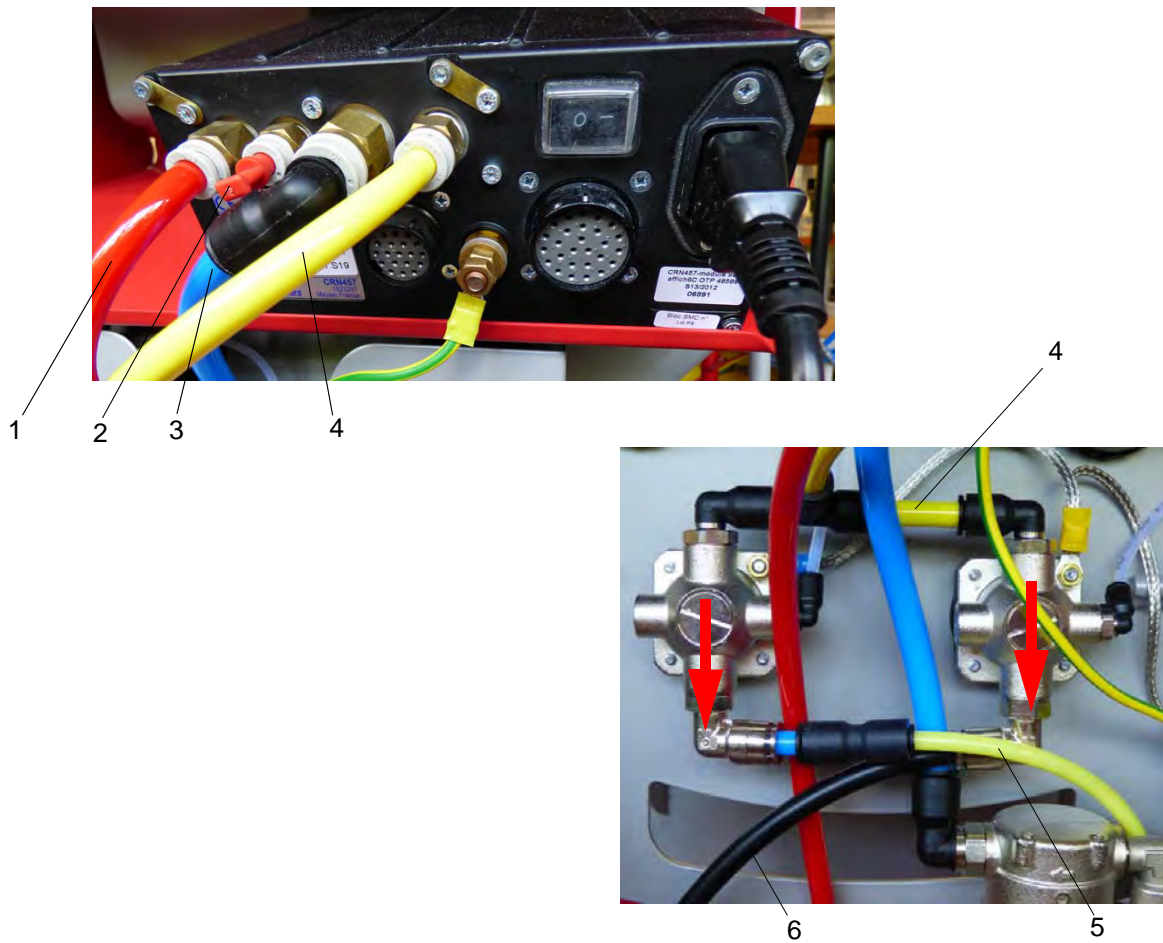

Reference	Hose name	Hose characteristics
1	Injection air powder pump	Red Polyurethane hose, dia: 8 mm
2	Closed outlet of dilution air	-
3	General air supply	Blue Polyurethane hose, dia.: 10 mm
4	Regulator air suply	Yellow Polyurethane hose, dia.: 8 mm
5	Fluidization air	Yellow Polyurethane hose - dia: 6 mm
6	Vibrator air supply	Black anti-static hose dia.: 8 mm

## 6.2. Connection of “Mach-Jet Gun” and mains plug

Connect the spray gun to plug “A” on the back of the control module ([see RT Nr 6336](#)).



**WARNING :** To avoid damaging the plug, make sure that the spray gun positioning pin is opposite the positioning pin on the CRN 457 base plate.

The plug is locked by pushing it into the socket; comply with positioning pins: The flat on the spray gun cable plug must be at the top, a “click” must be heard. The click indicates that the plug is correctly locked in position.

The plug is unlocked by pulling it out of the socket.



Positioning pins

The mains power cable is connected to the back of the CRN 457 module (see figure below). It is imperative to check that the plug sector is connected to the ground.



Mains power cable

Plug “A”, spray gun

## 7. Using the equipment "eJet2"

### 7.1. Main rules

The equipment has previously been installed according to the safety rules ([see § 1 page 4](#)) and the instructions indicated ([see § 6 page 9](#)), follow the steps described below:

- **Step 1:** Connect the ground cable of the cart to a conducting and connected ground part of the application booth; the ground potential must be equal to the potential of the part to be painted.
- **Step 2:** Supply electrically and pneumatically the equipment.
- **Step 3:** Fill the tank with powder and close the cover with clamps, **attention** tank under pressure in operation.
- **Step 4:** Put in operation the CRN 457 control module ([see RT Nr 6336](#)) (switch located in the back of the module). Configure the CRN 457 control module ([see RT Nr 6336](#)), operation with vibrating table.
- **Step 5:** Choose the type of needle and select on the spray gun or on the control module the suitable high voltage characteristic.
- **Step 6:** Direct the needle of the spray gun towards the booth and activate the trigger; adjust the regulator of the vibrator (recommended pressure 1 bar) and the regulator of fluidization (recommended pressure 1 bar).

#### 7.1.1. In Nondestructive testing version

The CSV 230 tank is equipped with a 2.7mm injector, a 2.7mm ejector and either a hose dia. 6mm or 7 mm delivered.

Close the CSV 230 tank shutter completely (position 0). The flow of the developer product is adjustable on the CRN 457 module or directly on the spray gun by varying the parameter of injection (0 - 12). If the flow is not sufficient, it is also possible to open slightly the shutter.

#### 7.1.2. In powdering version

This equipment can be used to coat complex powders, very strong flows can be then reached. However the limit of reasonable use of a conventional electrostatic spray gun (charge capacity) is reached at 15kg / hour of powder ( 250g / min ).

The CSV 230 tank is then equipped in option of a special powdering ejector (Dia: 1,7mm), of an EAV 9/ 13 hose and of a powder fitting (Dia: 10), [see § 9.1.3 page 23](#).

Adjust the injection parameter (on the CRN 457 module or directly on the spray gun) to 6. Then adjust the flow of powder by varying the position of the shutter on the tank.

For information, with a long 6m hose dia.9mm and with a standard powder

Shutter position	1	2	3	4	5
Powder flow (g/min)	40	120	160	230	680

## 8. Maintenance

### 8.1. Cleaning



**WARNING :** Cleaning operations must only be carried out using compressed air and a wet cloth. Neither water nor solvents must be used to clean the equipment (spray gun and control module). The equipment must be cleaned at the end of each shift.

- Check regularly the air filter cartridge replace if necessary.
- If there is water or oil in the filter, dump the bowl and check the air dryer or oil remover in the installation. To dump the bowl, unscrew the black plastic part located underneath the filter bowl.

### 8.2. Cleaning of the check valve fitted on the injection air supply

- **Step 1:** Swith off the air supplies.
- **Step 2:** Disconnect the hose upstream to the check valveby pressing on the green ring, then downstream on the red ring.



- **Step 3:** Then clean the check valve with compressed air. If necessary, clean the injector of the tank.

### 8.3. Dump of tank

#### 8.3.1. Procedure 1

- **Step 1:** Disconnect the air supplies on the tank.
- **Step 2:** Unscrew the ground thimble of the tank located on the side of the cart
- **Step 3:** Remove the cover by screwing the clamps.
- **Step 4:** Unscrew the three bolts securing the tank on the support. Remove the tank by taking care not shocking the vibrator.
- **Step 5:** Empty the tank in the booth then clean the remaining powder with compressed air.

#### 8.3.2. Procedure 2

- **Step 1:** Disconnect the injection air supply from the tank.
- **Step 2:** Place a recovery container under the tank
- **Step 4:** Unscrew the threaded ring and withdraw the injector/ ejector assembly upward. The powder falls then in the container. Clean the remaining powder with compressed air.



## 9. Spare parts

### 9.1. "e-Jet2" equipment, nondestructive testing version



## Europe version

Item	Part Number	Description	Qty	Sale unit	Maintenance level for Spare part (*)
	910020277	e-Jet2, nondestructive testing version	1	1	3
1	-	Cart ( <a href="#">see § 9.1.1 page 19</a> )	1	-	-
2	1524463	“Mach-Jet Gun” spray gun ( <a href="#">see RT Nr 6336</a> )	1	1	3
3	910014738	CSV 230 Tank ( <a href="#">see RT Nr 6431</a> )	1	1	3
4	1523297	CRN 457 control module ( <a href="#">see RT Nr 6336</a> )	1	1	3
5	910015302	CRN 457 securing kit on cart	1	1	3
		<b>Not shown</b>			
	E4PCAL206	Main power cable 10A 250V	1	1	3
	842635	5-metre ground cable, thimble dia.: 6	1	1	3
	910003576	Nondestructive testing powder union	1	1	2
	F6RLZX396	Quick release plug Dia: 6 mm	1	1	3

## ”US” Version

Item	Part Number	Description	Qty	Sale unit	Maintenance level for Spare part (*)
	910020548	e-Jet2, nondestructive testing version	1	1	3
1	-	Cart ( <a href="#">see § 9.1.1 page 19</a> )	1	-	-
2	1524463	“Mach-Jet Gun” spray gun ( <a href="#">see RT Nr 6336</a> )	1	1	3
3	910014738	CSV 230 Tank ( <a href="#">see RT Nr 6431</a> )	1	1	3
4	1523297	CRN 457 control module ( <a href="#">see RT Nr 6336</a> )	1	1	3
5	910015302	CRN 457 securing kit on cart	1	1	3
		<b>Not shown</b>			
	E4PCAL459	US Main power cable	1	1	3
	842635	5-metre ground cable, thimble dia.: 6	1	1	3
	F6RLHG362	Conical adapter	1	1	3
	910003576	Nondestructive testing powder union	1	1	2
	F6RLZX396	Quick release plug Dia: 6 mm	1	1	3

(\*)

**Level 1: Standard preventive maintenance**

**Level 2: Corrective maintenance**

**Level 3: Exceptional maintenance**



9.1.1. Cart  
Tank fastening assemblies

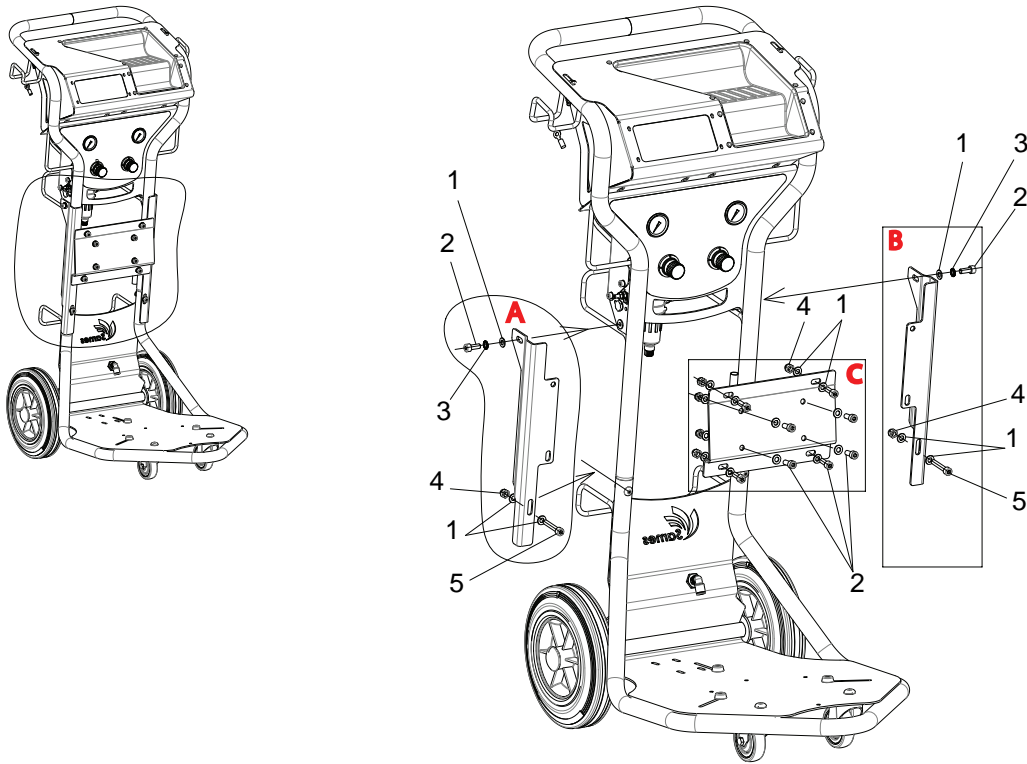

DES06247

Item	Part Number	Description	Qty	Sale unit	Maintenance level for Spare part (*)
	<b>A or B</b>	<b>Left or right fixing of the tank</b>	<b>1</b>	<b>-</b>	<b>-</b>
1	X2BDZU008	Zinc coated steel Z 8 U washer	3	1	3
2	X3AVSY283	Chc M8x20 zinc coated 8/8 screw	1	1	3
3	X2BDVX008	Fan washer AZ8	1	1	3
4	X2BEHS008	Nylstop self locking nut M8	1	1	3
5	X3AVSY288	Chc M8x45 zinc coated 8/8 screw	1	1	3
	<b>C</b>	<b>Central fixing of the tank</b>	<b>1</b>	<b>-</b>	<b>-</b>
1	X2BDZU008	Zinc coated Z 8 U washer	16	1	3
2	X3AVSY283	Chc M8x20 zinc coated 8/8 screw	8	1	3
4	X2BEHS008	Nylstop self locking nut M8	8	1	3

(\*)

Level 1: Standard preventive maintenance

Level 2: Corrective maintenance

Level 3: Exceptional maintenance

**Cart assembly**

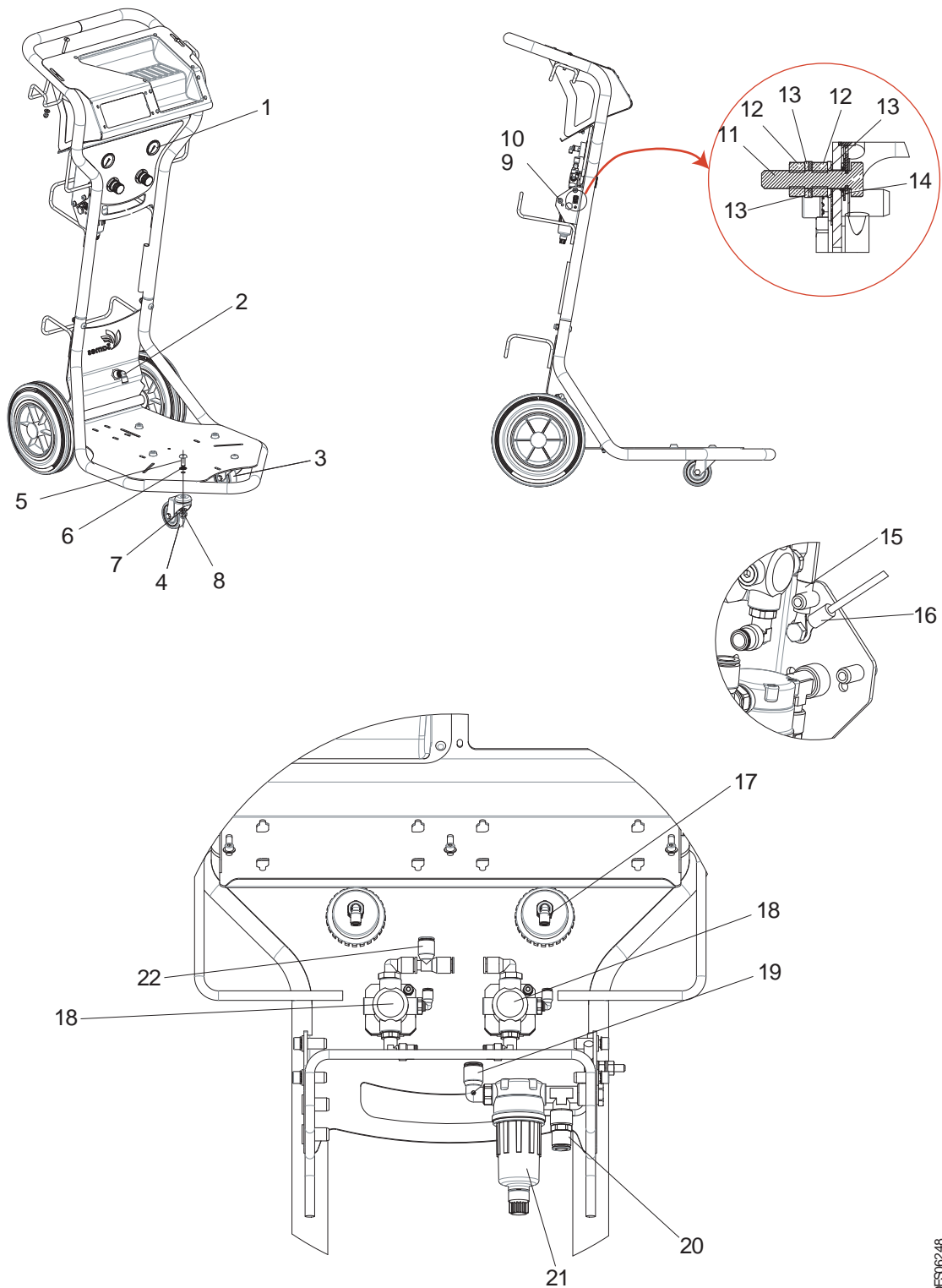

DES06248



Item	Part Number	Description	Qty	Sale unit	Maintenance level for Spare part (*)
1	EU9001879	Pressure gauge 4 bars	2	1	3
2	F6RLCS204	Elbow union	1	1	3
<b>Rollers and securing</b>					
3	EU9000064	Conductive pivoting roller	1	1	3
4	EU9000065	Pivoting roller	1	1	3
5	EU9000760	Black Chc M10 x 30 screw	2	1	3
6	EU9000837	Fan washer Dia.:10	2	1	3
7	X2BDZU010	Zinc coated Z10 U washer	2	1	3
8	X2BEHS010	Zinc coated M 10 U nylstop nut	2	1	3
<b>Securing back cover</b>					
9	X3AVSY223	Zinc coated Chc M6 x16 screw	4	1	3
10	EU9000835	Fan washer Dia:6	4	1	3
<b>Ground screw on cart</b>					
11	X7CVHA228	Brass H M6 x 30 screw	1	1	3
12	X7CEHU006	Brass H M6 U nut	2	1	3
13	X7DDZU006	Brass Z6 U washer	3	1	3
14	EU9000835	Fan washer Dia:6	1	1	3
<b>15</b>	<b>910014956</b>	<b>Ground strip</b>	<b>1</b>	<b>1</b>	<b>3</b>
<b>16</b>	<b>910014955</b>	<b>Ground wire CRN e-Jet2</b>	<b>1</b>	<b>1</b>	<b>3</b>
17	F6RLCS016	Female elbow fitting	2	1	3
<b>18</b>	<b>910014735</b>	<b>Regulator assembly</b> <a href="#">(see § 9.1.1.1 page 22)</a>	<b>2</b>	<b>1</b>	<b>2</b>
19	F6RLCS008	Male elbow fitting	1	1	3
20	F6RLUS225	Male union	1	1	3
21	160000152	Filtering cartridge - 5 µm	1	1	1
22	F6RLTS416	Tee fitting	1	1	3
-	F6RLDS145	Quick release elbow fitting (back of CRN)	1	1	3

(\*)

**Level 1: Standard preventive maintenance**

**Level 2: Corrective maintenance**

**Level 3: Exceptional maintenance**



9.1.1.1. Regulator assembly

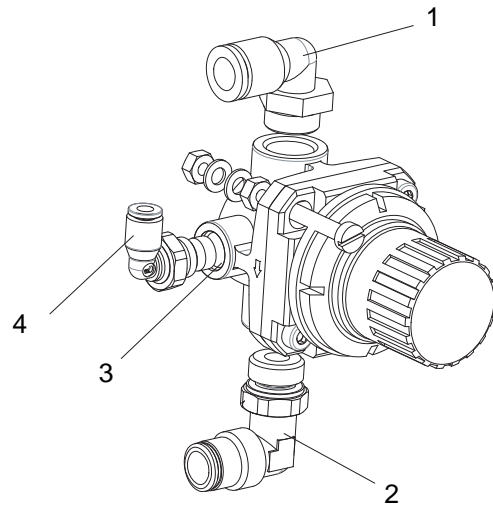

DES05497

Item	Part Number	Description	Qty	Sale unit	Maintenance level for Spare part (*)
	<b>910014735</b>	<b>Regulator assembly</b>	<b>2</b>	<b>1</b>	<b>2</b>
1	F6RLCS411	Male elbow fitting	1	1	3
2	130001160	Swivel fitting	1	1	3
3	EU5000050	Porous ring	1	1	2
4	EU9000062	Male elbow fitting	1	1	3

(\*)

**Level 1: Standard preventive maintenance**

**Level 2: Corrective maintenance**

**Level 3: Exceptional maintenance**

### 9.1.2. Hoses

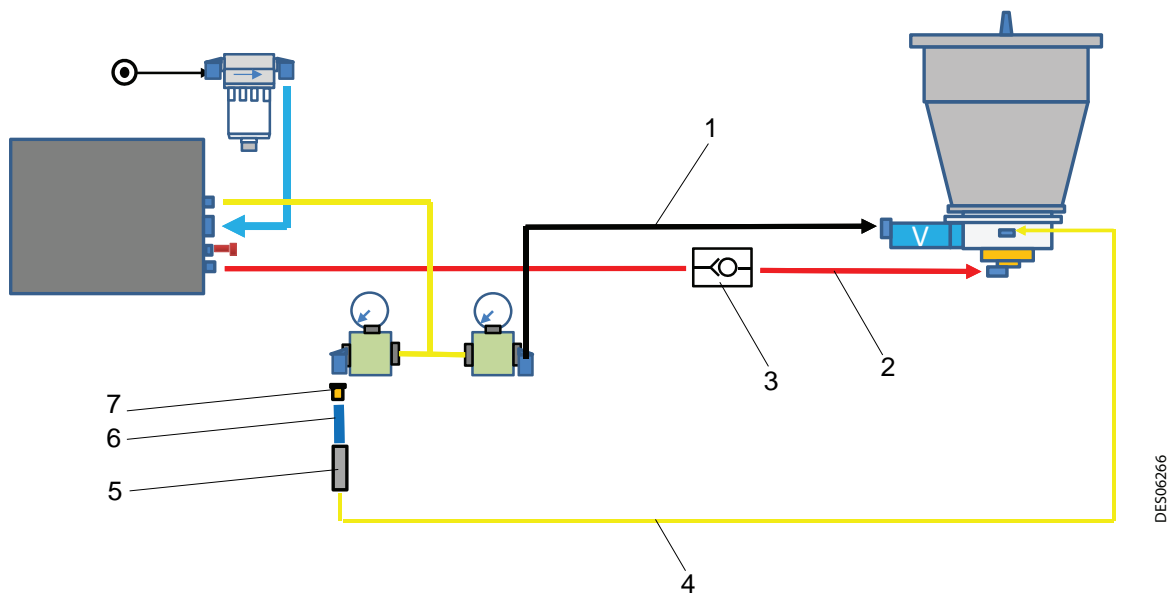

Item	Part Number	Description	Qty	Sale unit	Maintenance level for Spare part (*)
1	130000624	Black antistatic hose Dia: 5.5 x 8	1.05	m	3
2	U1GRBW197	Red Polyurethane hose, Dia: 5.5 x 8	1.1	m	2
3	F6RRAF043	Check valve	1	1	2
4	U1CBBJ001	Yellow rilsan hose, Dia: 4x6	0.9	m	2
5	F6RLUS483	Dual union	1	1	3
6	U1CBBT003	Blue rilsan hose, Dia: 6x8	0.04	m	3
7	900002308	Brass restrictor	1	1	3

### 9.1.3. Options for use in powdering version

Item	Part Number	Description	Qty	Sale unit	Maintenance level for Spare part (*)
	441216	Ejector for powdering	1	1	2
	U1FGBA104	Swivel fitting	6 m	m	3
	1409627	Powder fitting Dia.:10	1	1	2