

DIVISION: 05 00 00—METALS
Section: 05 52 00—Metal Railings
Section: 05 73 13—Glazed Decorative Metal Railings

DIVISION: 08 00 00—OPENINGS
Section: 08 81 00—Glass Glazing
Section: 08 88 00—Special Function Glazing

REPORT HOLDER:

Q-RAILING USA CO.

EVALUATION SUBJECT:

EASY GLASS RAILING SYSTEMS

1.0 EVALUATION SCOPE

Compliance with the following codes:

- 2021, 2018 and 2015 International Building Code® (IBC)
- 2021, 2018 and 2015 International Residential Code® (IRC)

For evaluation for compliance with codes adopted by Los Angeles Department of Building and Safety (LADBS), see [ESR-4688 LABC and LARC Supplement](#).

Properties evaluated:

- Structural
- Durability

2.0 USES

The Easy Glass Railing Systems are intended for use in interior and exterior locations of all construction types.

3.0 DESCRIPTION

The Easy Glass Railing Systems consist of continuous aluminum base shoes, cap rails (if applicable), handrails (if applicable), edge protection (if applicable), glass panels and Wedge or Q-disk dry glaze mechanisms.

3.1 Top Rails: The cap rails (also known as top rails) are manufactured from ASTM A554 304 or 316 stainless steel (See Table 1 and Figure 4).

3.1.1 Edge Protection: Edge Protection is a non-structural profile placed on the top edge of balustrade glass. Edge protection is manufactured from ASTM A554 316 stainless steel (See Table 2 and Figure 5).

3.2 Handrails: The handrails are manufactured from ASTM A554 304 or 316 stainless steel. (See Table 3 and Figure 6).

3.3 Handrail Brackets: The handrail brackets are manufactured from ASTM A276 304 or 316 stainless steel. (See Table 4 and Figure 7).

3.4 Laminated Glass Panels: The laminated glass panels must comply with ASTM C1172 and Category II of CPSC 16 CFR Part 1201 or Class A of ANSI Z97.1. The panels must consist of two lites of glass with an interlayer.

Lites: The lites must be Kind FT tempered glass complying with ASTM C1048 and have a minimum Modulus of Rupture (Fr) ≥ 24,000 psi (165 MPa).

Interlayer: The interlayer must be a minimum 0.060-inch-thick (1.52 mm) and have a minimum shear modulus of 3828 psi (26.4 MPa) for T ≤ 122°F (50°C).

The minimum glass thicknesses in this report must be constructed as follows:

- The 9/16-inch (14.29 mm) laminated tempered glass must be made from 1/4-inch (6.35 mm) nominal tempered glass with a minimum true thickness of 0.22 inch (5.59 mm). The overall true thickness of the laminated tempered glass must be a minimum of 0.50 inch (12.7 mm).
- The 11/16-inch (17.46 mm) laminated tempered glass must be made from 5/16-inch (7.94 mm) nominal tempered glass with a minimum true thickness of 0.29 inch (7.37 mm). The overall true thickness of the laminated tempered glass must be a minimum of 0.64 inch (16.26 mm).
- The 27/32-inch (21.43 mm) laminated tempered glass must be made from 3/8-inch (9.53 mm) nominal tempered glass with a minimum true thickness of 0.36 inch (9.14 mm). The overall true thickness of the laminated tempered glass must be a minimum of 0.78 inch (19.81 mm).
- The 1-inch (25.4 mm) laminated tempered glass must be made from 1/2-inch (12.7 mm) nominal tempered glass with a minimum true thickness of 0.47 inch (11.94 mm). The overall true thickness of the laminated tempered glass must be a minimum of 1.0 inch (25.4 mm).
- The 1-1/16-inch (26.99 mm) laminated tempered glass must be made from 1/2-inch (12.7 mm) nominal tempered glass with a minimum true thickness of 0.47 inch (11.94 mm). The overall true thickness of the laminated tempered glass must be a minimum of 1.0 inch (25.4 mm).

3.5 Base Shoe: The Easy Glass base shoes are manufactured from ASTM B221 6063-T6 aluminum (See Figure 8).

3.6 Dry Glazing Systems:

3.6.1 Wedge System: The wedge system for Easy Glass Slim and Easy Glass Max consists of an ABS plastic L-shape inlay and an ABS plastic wedge. The wedge is tapped in until sufficiently fixed as specified in the manufacturer's installation instructions using the Easy Glass multi-tool. Easy Glass wedge kits are provided with rubber sets to match selected glass thickness. See Figure 2.

3.6.2 Q-disk System: The Q-disk system for Easy Glass Smart and Easy Glass Prime consist of an ABS plastic inlay and the ABS plastic Q-disk. The Q-disk is tightened to one pound-foot torque using the specific tool. Glass is adjustable by moving the inlay left-right. Easy Glass Q-disk kits are provided with rubber gaskets to match selected glass thickness. See Figure 3.

3.7 Durability: The Easy Glass materials supplied by Q-railing USA Co. are inherently corrosion-resistant. The material type specified must be appropriate for the environment of the installation. Information verifying the durability must be submitted to the code official, when requested.

4.0 DESIGN AND INSTALLATION

4.1 Installation:

Installation of the guardrail systems, including the handrails and top rails, must comply with the manufacturer's published instructions, this report, and the IBC or IRC, as applicable.

The manufacturer's published installation instructions must be available at the jobsite at all times during installation. In the event of a conflict between this report and the manufacturer's instructions, this report governs.

4.1.1 Top Rails: The maximum spans in Table 1 are based on the capacities of the top rails. At the balustrade end, the top rail must be attached to a structure, wall, or post able to support the code-prescribed loads listed in Section 4.2.1.

4.1.2 Edge Protection: The edge protection in Table 2 may be installed on the top edge of glass where a handrail is used or installation without a top rail is permitted. The edge protection is not designed to carry the code prescribed loads listed in Section 4.2.1 of this report.

4.1.3 Handrails:

4.1.3.1 General: Handrails must be installed as required per the applicable code.

4.1.3.2 Brackets: The handrail brackets are installed through holes located near the ends of the glass panels. See Table 4 for compatible handrail and bracket combinations.

4.1.3.3 Installation: Handrails are installed to glass panels using the through-glass mounting brackets shown in Figure 7. The mounting brackets are installed at the ends of the glass panels. The holes in the laminated glass panels must comply with Section 4.3 of this report.

4.1.3.4 Spacing: The handrail bracket spacing must be within the limits shown in Table 4.

4.1.4 Dry Glazing Mechanisms:

The wedge supports, used with the Easy Glass Slim and Easy Glass Max base shoes, must be spaced a maximum of 3 inches from the ends of the base shoe and a maximum

of 6 inches on center in the base shoe. The Q-disk supports, used with the Easy Glass Smart and Easy Glass Prime base shoes, must be spaced a maximum of 4.92 inches from the ends of the base shoe and a maximum of 9.84 inches on center in the base shoe.

4.1.5 Installation Without a Top Rail or Handrail:

The Easy Glass systems (Wedge or Q-disk) may be installed without a top rail or handrail when using laminated tempered glass panels with an interlayer meeting the requirements of Section 3.4 and dimensions meeting the following:

- $1\frac{1}{16}$ -inch thick (17.46 mm) laminated tempered glass with a height from the top of the base shoe up to $37\frac{1}{2}$ inches (952.5 mm)
- $2\frac{7}{32}$ -inch thick (21.43 mm), 1-inch thick (25.4 mm) or $1\frac{1}{16}$ -inch thick (26.99 mm) laminated tempered glass with a height from the top of the base shoe up to 42 inches (1066.8 mm)

Installation without a top rail or handrail complies with the Exceptions noted in IBC Section 2407.1.2 and IRC Section R308.4.4.1.

4.2 Design:

4.2.1 Live Loads: The following project specific live loads must be identified while limiting stresses within the glass panels to 6,000 psi (41.3 MPa) [modulus of rupture (24,000 psi) divided by a safety factor of 4] and the deflection to 1 inch (25.4 mm) or less:

- A live load of 50 lb/ft applied in any direction along the handrail or top rail.
- A single concentrated live load of 200 pounds (0.89 kN) applied in any direction at any point on the top of glass panel.
- A horizontally applied normal live load of 50 pounds applied perpendicular to the glass panel on an area not to exceed 12-inches-by-12 inches (305 mm-by-305 mm).

Tables 5 through 8 provide the maximum height of the guard (Hg) for the base shoes and glass thicknesses based on allowable stress and deflection with an applied live load of 50 plf (0.73 kN/m). For installations in accordance with the IRC, the 50 plf (0.73 kN/m) load is not applicable.

4.2.2 Wind Loads: The allowable stress due to wind loading is 10200 psi (70.3 MPa). The required wind load must be determined by a qualified design professional based on the project-specific conditions, taking into account the balustrade location on the structure, and must not exceed the values shown in the tables of this report. Tables 5 through 8 provide the allowable wind loads for the various combinations of base shoes and glass thicknesses.

4.3 Holes and Notches: Holes and notches are permitted for mounting handrails. Holes and notches must conform to ASTM C1048 and must not exceed 2 inches wide (50.8 mm). Notches or holes must not exceed $\frac{1}{12}$ of the glass width. Holes or notches must not be located within the first third of the glass panel (balustrade) height from the shoe.

5.0 CONDITIONS OF USE

The Easy Glass systems described in this report comply with, or are a suitable alternative to what is specified in, those codes listed in Section 1.0 of this report, subject to the following conditions:

5.1 The product is limited to installation where it is not subject to vehicle impacts.

- 5.2 The supporting structure and anchorage of the system to the supporting structure is outside of the scope of this report and must be designed by a registered design professional and constructed to support the loads imposed by the guards in accordance with the applicable code.
 - 5.3 The systems described in this report must not be used in Wind-borne Debris Regions. Use of the Easy Glass railing systems in Wind-borne Debris Regions is outside the scope of this report.
 - 5.4 Drawings and design details for the Easy Glass systems, using the information noted in this report, must be included on construction plans submitted to the code official for approval. The drawings and details must be prepared by a registered design professional where required by the statutes of the jurisdiction in which the project is to be constructed.
 - 5.5 Drawings and design details for the Easy Glass systems, using the information noted in this report, must be included on construction plans submitted to the code official for approval. The drawings and details must be prepared by a registered design professional where required by the statutes of the jurisdiction in which the project is to be constructed.
 - 5.6 When installed where the base shoe anchors are exposed to moisture, the base shoe anchors must be of a material intended for the use and identified by the manufacturer as acceptable for exterior applications.
 - 5.7 All metals in contact with aluminum must either be an alloy approved for direct aluminum contact, or isolated from the aluminum by an approved coating.
 - 5.8 Both ends of the top rails must be supported by a wall or post, and the attachment must be capable of supporting a concentrated horizontal shear load of 200lbs (0.89kN).
 - 5.9 Glass sand-blasted or etched on surfaces 1 (outside face) or 4 (inside face) is outside the scope of this report.
 - 5.10 Use of the system as a grab bar is outside the scope of this report.
 - 5.11 All laminated glass panels must be fully tempered Type II laminated glass, with an interlayer complying with Section 3.4, and fabricated and inspected in accordance with ASTM C1172. The glass fabricator must provide certification of compliance with ASTM C1172 for fully tempered glass. Glass must be procured directly from a qualified glass fabricator and is not produced or supplied by Q-railing USA Co.
 - 5.12 The Easy Railing System components, except for the glass panels, are supplied by Q-railing USA Co.
- 6.0 EVIDENCE SUBMITTED**
- Data in accordance with the ICC-ES Acceptance Criteria for Glass Railing and Balustrade Systems (AC439) dated April 2019 (editorially revised August 2020).
- 7.0 IDENTIFICATION**
- 7.1 The Easy Glass Railing System components described in this report are identified by a label on the packaging bearing the manufacturer’s name; product description and/or part number; and the ICC-ES evaluation report number (ESR-4688).
 - 7.2 The glass panels must be identified as specified in the applicable code.
 - 7.3 The report holder’s contact information is the following:
Q-RAILING USA CO.
14321 FRANKLIN AVENUE, SUITE A
TUSTIN, CA 92780
(714) 259-1372
www.q-railing.com
sales.us@q-railing.com

TABLE 1—TOP RAIL SPAN LENGTHS
 (Based on the top rail spanning over a minimum of three glass panels)

SHAPE	PART NUMBER	MATERIAL	MAXIMUM SPAN (inches) ^{1,2,4}
Round	MOD 6920.042	304/316 Stainless Steel	48- ¹ / ₂
	MOD 6920.048	304/316 Stainless Steel	47- ¹ / ₄
	MOD 6920.060	304/316 Stainless Steel	47- ¹ / ₄

For SI: 1 inch = 25.4 mm.

1. Based on the capacity of the top rail considering the worst case between a 50 plf uniform load and a 200 lb. concentrated load.
2. The maximum middle glass panel widths must not be greater than the maximum middle top rail span.
3. The maximum end glass panel must not be greater than the maximum end top rail span, except as noted in Footnote 5.
4. The glass panels widths must not be less than the minimum glass panel width noted in Tables 5 through 8.
5. At the balustrade end, the top rail must be attached to a structure, wall, or post able to support the code-prescribed loads listed in Section 4.2.1.

TABLE 2—EDGE PROTECTION¹

SHAPE	PART NUMBER	MATERIAL
Edge Protection	MOD 6940.114	316 Stainless Steel
	MOD 6940.118	316 Stainless Steel
	MOD 6940.122	316 Stainless Steel

1. Edge protection must be used with a handrail and is not a substitute for a top rail.

TABLE 3—HANDRAIL PROFILES

SHAPE	PART NUMBER	MATERIAL
Round	MOD 8925.038	304/316 Stainless Steel
	MOD 0900.038	304/316 Stainless Steel
	MOD 8925.248	304/316 Stainless Steel
	MOD 0900.248	304/316 Stainless Steel
Square	MOD 4900.040	304/316 Stainless Steel
	MOD 4925.040	304 Stainless Steel

TABLE 4—HANDRAIL BRACKETS¹

SHAPE	PART NUMBER	MATERIAL	COMPATIBLE HANDRAIL PROFILES	MAXIMUM BRACKET SPACING (inches)
L-shape, adjustable	MOD 0150.000 ²	316 Stainless Steel	MOD 4900.040, MOD 4925.040	42- ¹ / ₂
L-shape, adjustable	MOD 0150.038 ²	304/316 Stainless Steel	MOD 8925.038, MOD 0900.038	42- ¹ / ₂
L-shape, adjustable	MOD 0150.048 ²	316 Stainless Steel	MOD 8925.248, MOD 0900.248	42- ¹ / ₂
L-shape, adjustable	MOD 0151.038 ²	304/316 Stainless Steel	MOD 8925.038, MOD 0900.038	42- ¹ / ₂
L-shape, adjustable	MOD 0155.000 ²	304/316 Stainless Steel	MOD 4900.040, MOD 4925.040	42- ¹ / ₂
L-shape, adjustable	MOD 0155.038 ²	304/316 Stainless Steel	MOD 8925.038, MOD 0900.038	42- ¹ / ₂
L-shape, adjustable	MOD 0155.048 ²	304/316 Stainless Steel	MOD 8925.248, MOD 0900.248	42- ¹ / ₂
L-shape, adjustable	MOD 0156.038 ²	304/316 Stainless Steel	MOD 8925.038, MOD 0900.038	42- ¹ / ₂
L-shape, adjustable	MOD 4155.000 ²	304/316 Stainless Steel	MOD 4900.040, MOD 4925.040	42- ¹ / ₂
L-shape, adjustable	MOD 4155.038 ²	304/316 Stainless Steel	MOD 8925.038, MOD 0900.038	42- ¹ / ₂
L-shape	MOD 0117.038	304/316 Stainless Steel	MOD 8925.038, MOD 0900.038	42- ¹ / ₂
L-shape	MOD 0117.048	304/316 Stainless Steel	MOD 8925.248, MOD 0900.248	42- ¹ / ₂
L-shape	MOD 9350.038	304 Stainless Steel	MOD 8925.038, MOD 0900.038	42- ¹ / ₂

1. All holes and notches must comply with Section 4.3.
2. Adjustable height of vertical rod measured from centerline of horizontal rod to centerline of circular or square handrail must less than or equal to 2.75 inches. See dimension B in Figure 1 for reference.

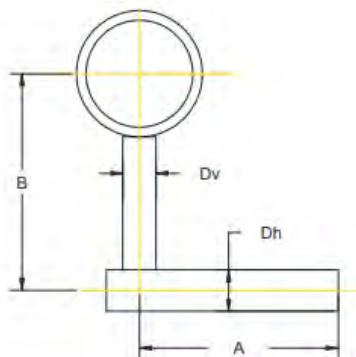

FIGURE 1—ADJUSTABLE HANDRAIL BRACKET

TABLE 5—EASY GLASS SLIM WIND LOAD STRENGTHS¹

Base Shoe Profile ^{3,4}	Glass Thickness (in.)	Min. Panel Width (in)	Interlayer Shear Modulus ² (psi)	Max. Guard Height, H _g (in.) ^{5,7}	M _{all wind} (lb-in/ft) ⁸	Allowable wind pressure (W _{all wind}), psf ⁹
Top Mount ⁶ (MOD 6904)	9/16	37.469	3828	42	1907	30
Fascia Mount ¹⁰ (MOD 6905)	9/16	42	3828	42	2426	30

For SI: 1 inch = 25.4 mm; 1 ft = 305mm; 1lb = 4.45 N

1. A cap rail or handrail is required for all installations.
2. Minimum interlayer shear modulus for T <= 122° F.
3. See Figure 8 for Base Shoe Profiles.
4. Wedge dry mount mechanism must be used with the specified base shoe profiles.
5. H_g – height of top of glass above finished floor.
6. Deflection of the glass component is less than 1-inch (25.4 mm) under a live load of 50 lbs/ft. Other loads in Section 4.2.1 must be considered for deflection.
7. 6000 psi allowable stress of glass not exceeded under a live load of 50 lbs/ft. Other loads in Section 4.2.1 must be considered for allowable stress.
8. $M_{all\ wind} (lb-in/ft) = (W_{all\ wind} * 0.55 * H^2) / 12$; H indicates glass height above top of base shoe; units: W_{all wind} (psf), H (in)
9. Does not exceed allowable wind load stresses of ASTM E1300.
10. Deflection of the glass component exceeds 1-inch (25.4 mm) under a live load of 50 lbs/ft, but allowable stress of 6000 psi is not exceeded. Other loads in Section 4.2.1 must be considered for deflection

TABLE 6—EASY GLASS SMART WIND LOAD STRENGTHS¹

Base Shoe Profile ^{3,4}	Glass Thickness (in.)	Min. Panel Width (in)	Interlayer Shear Modulus ² (psi)	Max. Guard Height, H _g (in.) ^{5,7}	M _{all wind} (lb-in/ft) ⁸	Allowable wind pressure (W _{all wind}), psf ⁹
Top Mount ⁶ (MOD 6930)	9/16	37.469	3828	42	1930	30
Top Mount ^{6,11} (MOD 6930)	11/16	37.469	3828	42	3861	60
Fascia Mount ¹⁰ (MOD 6931)	9/16	42	3828	42	2426	30
Fascia Mount ⁶ (MOD 6931)	11/16	42	3828	42	2426	30
F- Top Mount ⁶ (MOD 6932)	9/16	37.469	3828	42	1931	30
F- Top Mount ^{6,11} (MOD 6932)	11/16	37.469	3828	42	3861	60
Y-Fascia Mount ¹⁰ (MOD 6933)	9/16	42	3828	42	2426	30
Y-Fascia Mount ⁶ (MOD 6933)	11/16	42	3828	42	2426	30

For SI: 1 inch = 25.4 mm; 1 ft = 305mm; 1lb = 4.45 N

1. A cap rail or handrail is required for all installations, unless noted in Section 4.1.5 and by Footnote 11.
2. Minimum interlayer shear modulus for T <= 122° F.
3. See Figure 8 for Base Shoe Profiles.
4. Q-disk dry mount mechanism must be used with the specified base shoe profiles.
5. H_g – height of top of glass above finished floor.
6. Deflection of the glass component is less than 1-inch (25.4 mm) under a live load of 50 lbs/ft. Other loads in Section 4.2.1 must be considered for deflection.
7. 6000 psi allowable stress of glass not exceeded under a live load of 50 lbs/ft. Other loads in Section 4.2.1 must be considered for allowable stress.
8. $M_{all\ wind} (lb-in/ft) = (W_{all\ wind} * 0.55 * H^2) / 12$; H indicates glass height above top of base shoe; units: W_{all wind} (psf), H (in)
9. Does not exceed allowable wind load stresses of ASTM E1300.
10. Deflection of the glass component exceeds 1-inch (25.4 mm) under a live load of 50 lbs/ft, but allowable stress of 6000 psi is not exceeded. Other loads in Section 4.2.1 must be considered for deflection
11. May be installed without a cap rail or handrail.

TABLE 7—EASY GLASS PRIME WIND LOAD STRENGTHS¹

Base Shoe Profile ^{3,4}	Glass Thickness (in.)	Min. Panel Width (in)	Interlayer Shear Modulus ² (psi)	Max. Guard Height, H _g (in.) ^{5,6,7}	M _{all wind} (lb-in/ft) ⁸	Allowable wind pressure (W _{all wind}), psf ⁹
Top Mount ¹⁰ (MOD 6960)	11/16	36.875	3828	42	4176	67
Top Mount ¹⁰ (MOD 6960)	27/32	36.875	3828	42	4176	67
Fascia Mount (MOD 6961)	11/16	42	3828	42	4366	54
Fascia Mount ¹⁰ (MOD 6961)	27/32	42	3828	42	4366	54
F- Top Mount ¹⁰ (MOD 6962)	11/16	42	3828	42	4279	67
F- Top Mount ¹⁰ (MOD 6962)	27/32	42	3828	42	4279	67
Y-Fascia Mount (MOD 6963)	11/16	42	3828	42	4366	54
Y-Fascia Mount ¹⁰ (MOD 6963)	27/32	42	3828	42	4366	54

For SI: 1 inch = 25.4 mm; 1 ft = 305mm; 1lb = 4.45 N

1. A cap rail or handrail is required for all installations, unless noted in Section 4.1.5 and by Footnote 10.
2. Minimum interlayer shear modulus for T <= 122° F.
3. See Figure 8 for Base Shoe Profiles.
4. Q-disk dry mount mechanism must be used with the specified base shoe profiles.
5. H_g – height of top of glass above finished floor.
6. Deflection of the glass component is less than 1-inch (25.4 mm) under a live load of 50 lbs/ft. Other loads in Section 4.2.1 must be considered for deflection.
7. 6000 psi allowable stress of glass not exceeded under a live load of 50 lbs/ft. Other loads in Section 4.2.1 must be considered for allowable stress.
8. M_{all wind} (lb-in/ft) = (W_{all wind}*0.55*H²)/12; H indicates glass height above top of base shoe; units: W_{all wind} (psf), H (in)
9. Does not exceed allowable wind load stresses of ASTM E1300.
10. May be installed without a cap rail or handrail.

TABLE 8—EASY GLASS MAX WIND LOAD STRENGTHS¹

Base Shoe Profile ^{3,4}	Glass Thickness (in.)	Min. Panel Width (in)	Interlayer Shear Modulus ² (psi)	Max. Guard Height, H _g (in.) ^{5,6,7}	M _{all wind} (lb-in/ft) ⁸	Allowable wind pressure (W _{all wind}), psf ⁹
Top Mount (MOD 6926)	27/32	36.875	3828	42	4666	75
Top Mount (MOD 6926)	1	36.875	3828	42	7466	120
Top Mount (MOD 6926)	1- ¹ / ₁₆	36.875	3828	42	7466	120
Fascia Mount (MOD 6935)	27/32	42	3828	42	3638	45
Fascia Mount (MOD 6935)	1	42	3828	42	8085	100

For SI: 1 inch = 25.4 mm; 1 ft = 305mm; 1lb = 4.45 N

1. Systems within tabulated parameters may be installed without a cap rail or handrail.
2. Minimum interlayer shear modulus for T <= 122° F.
3. See Figure 8 for Base Shoe Profiles.
4. Wedge dry mount mechanism must be used with the specified base shoe profiles.
5. H_g – height of top of glass above finished floor.
6. Deflection of the glass component is less than 1-inch (25.4 mm) under a live load of 50 lbs/ft. Other loads in Section 4.2.1 must be considered for deflection.
7. 6000 psi allowable stress of glass not exceeded under a live load of 50 lbs/ft. Other loads in Section 4.2.1 must be considered for allowable stress.
8. M_{all wind} (lb-in/ft) = (W_{all wind}*0.55*H²)/12; H indicates glass height above top of base shoe; units: W_{all wind} (psf), H (in)
9. Does not exceed allowable wind load stresses of ASTM E1300.

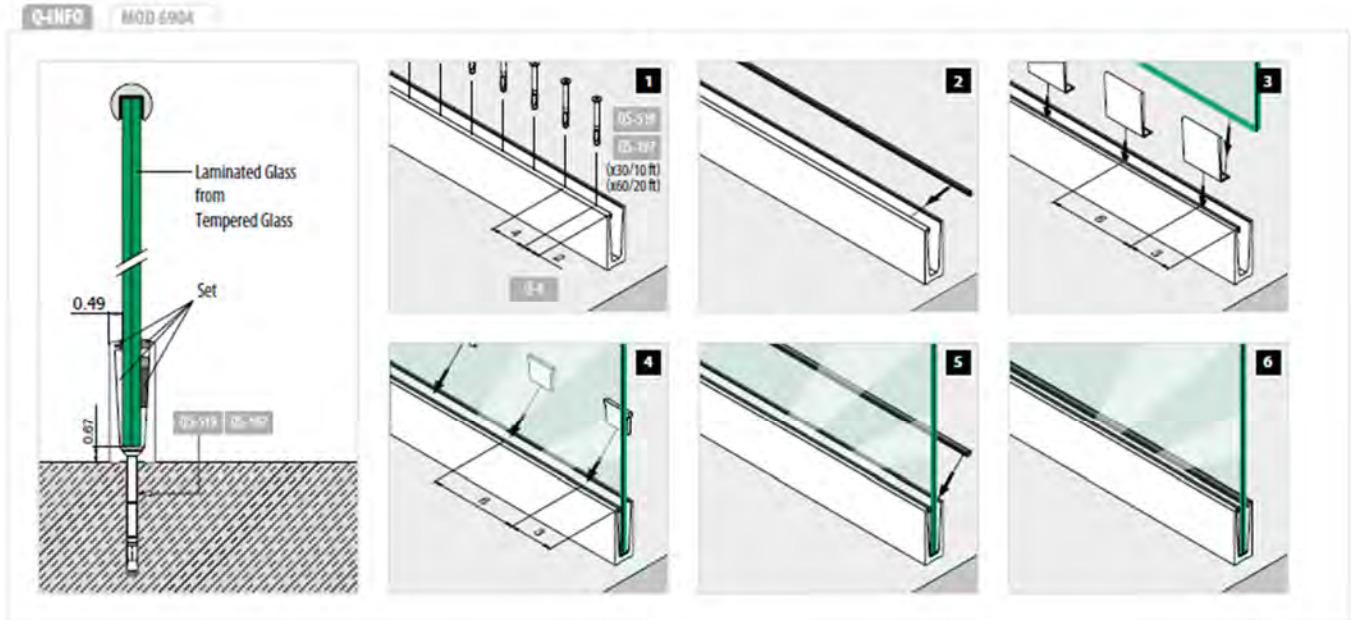

FIGURE 2—GUARD RAIL ASSEMBLY COMPONENTS (WEDGE SYSTEM)

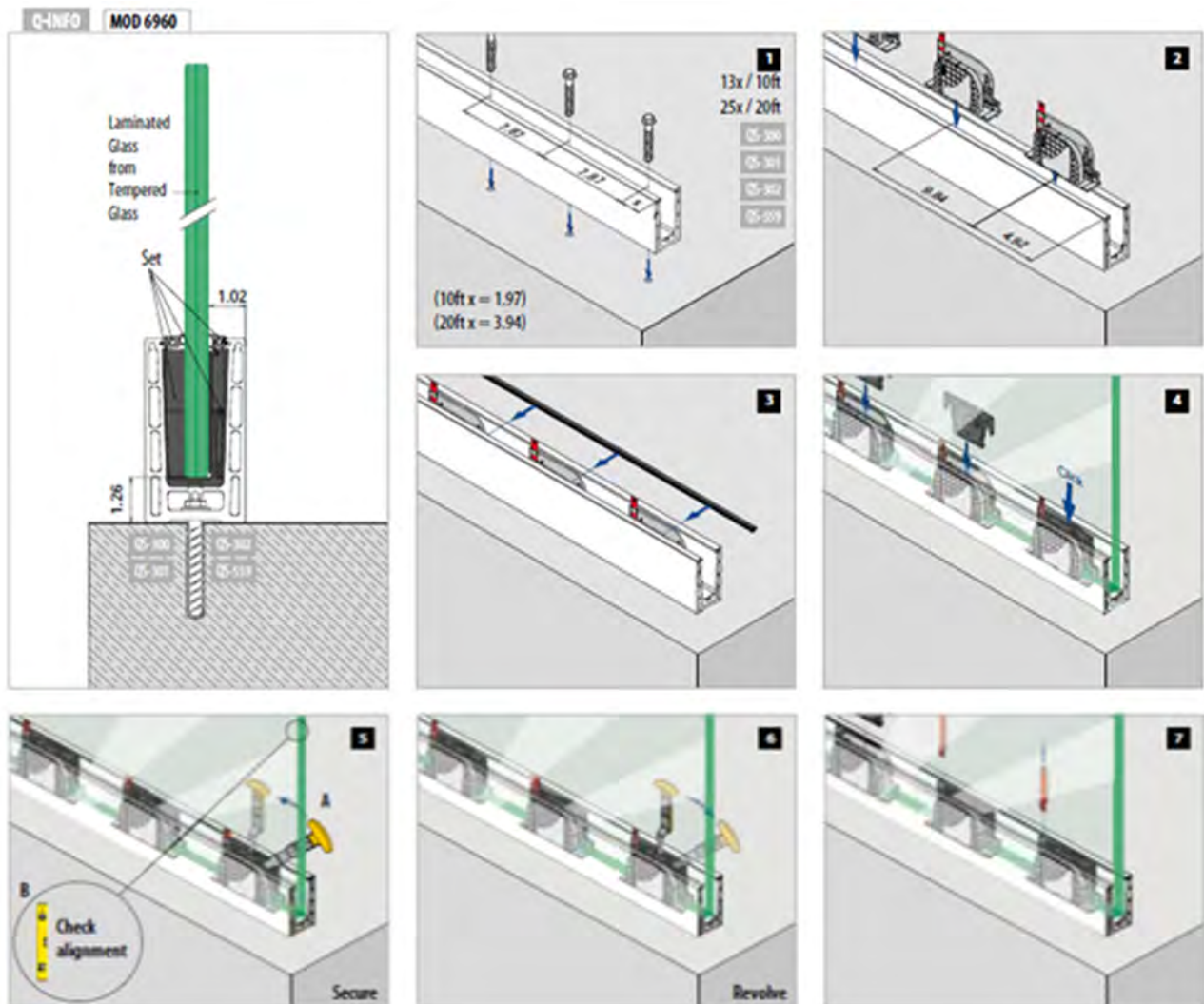

FIGURE 3—GUARD RAIL ASSEMBLY COMPONENTS (Q-DISK SYSTEM)

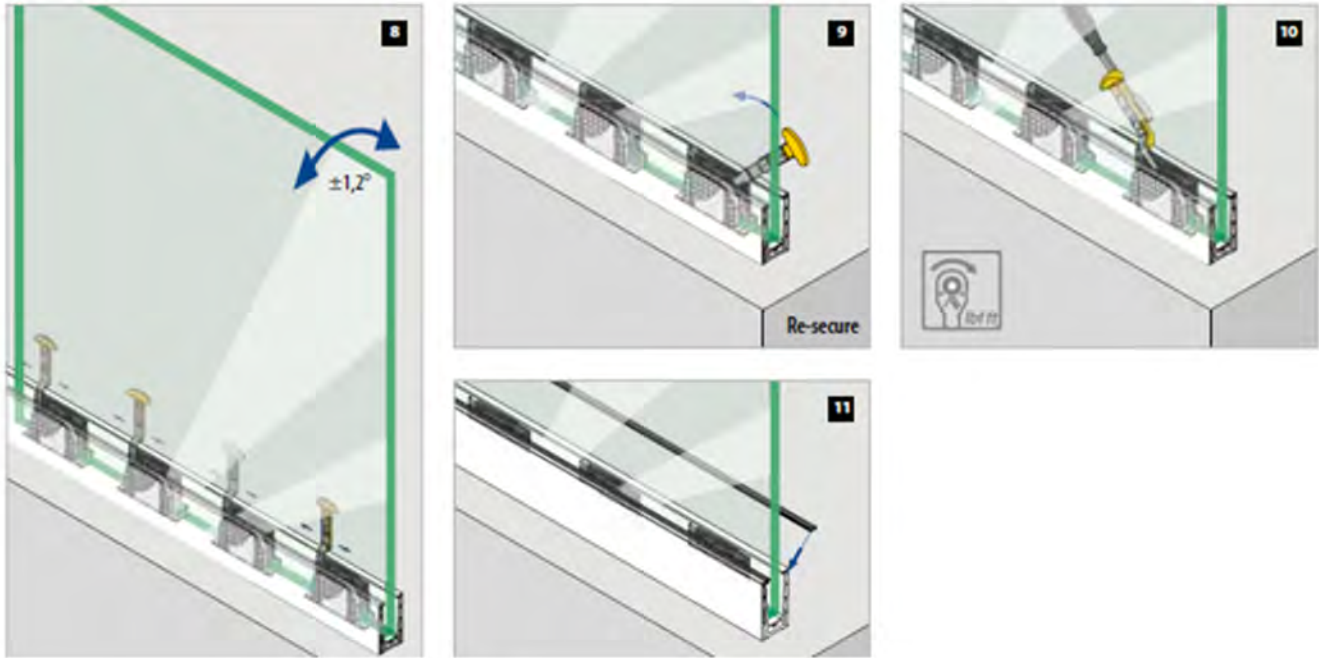
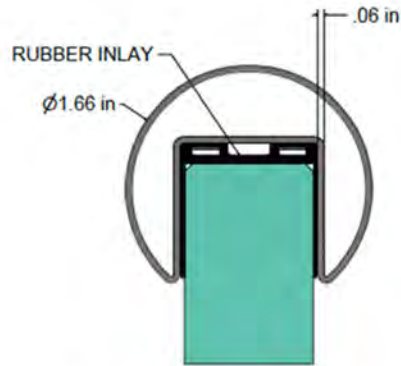
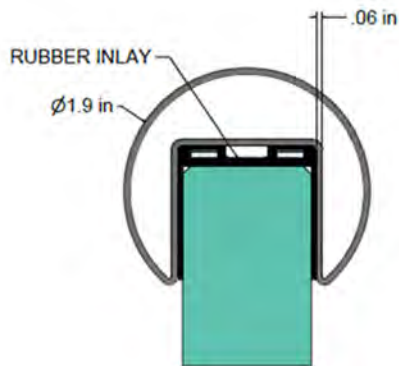

FIGURE 3 (CONT'D)—GUARD RAIL ASSEMBLY COMPONENTS (Q-DISK SYSTEM)



Ø 1.66 in CAP RAIL - ROUND
MAT.: SS 304, SS 316



Ø 1.9 in CAP RAIL - ROUND
MAT.: SS 304, SS 316

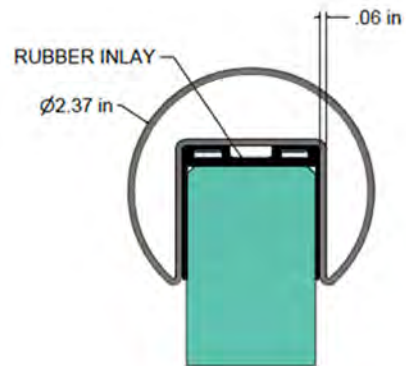

Ø 2.37 in CAP RAIL - ROUND
MAT.: SS 304, SS 316

FIGURE 4—TOP RAIL PROFILES

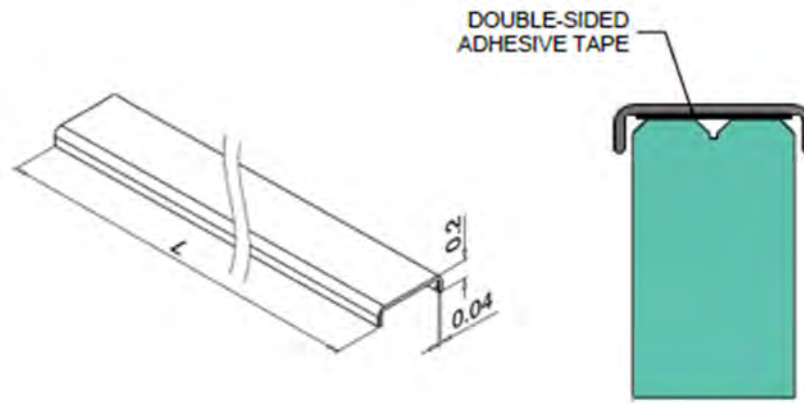

MOD 6940 (EDGE PROTECTION, RECTANGULAR, SS 316)
(GLASS THICKNESS: 1/2" - 27/32")

FIGURE 5—EDGE PROTECTION



MOD 8925 / 0900

Ø 1-1/2" (38.1 mm)

304		
INDOOR	X	
13.8925.038.12	0.078" (2.0 mm)	L = 8.2' (2500 mm)
13.0900.038.12	0.078" (2.0 mm)	L = 16.4' (5000 mm)
316		
OUTDOOR	X	
14.8925.038.12	0.078" (2.0 mm)	L = 8.2' (2500 mm)
14.0900.038.12	0.078" (2.0 mm)	L = 16.4' (5000 mm)

Ø 1.9" (48.3 mm)

304		
INDOOR	X	
13.8925.248.12	0.078" (2.0 mm)	L = 8.2' (2500 mm)
13.0900.248.12	0.078" (2.0 mm)	L = 16.4' (5000 mm)
316		
OUTDOOR	X	
14.8925.248.12	0.078" (2.0 mm)	L = 8.2' (2500 mm)
14.0900.248.12	0.078" (2.0 mm)	L = 16.4' (5000 mm)

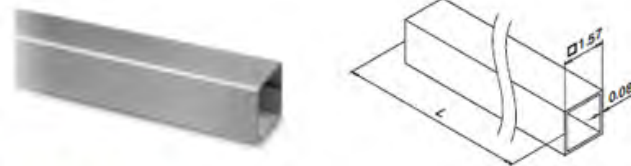

MOD 4925 / 4900

304		
INDOOR		
13.4925.040.12	1.57" x 1.57" x 0.078" (40 x 40 x 2.0 mm)	L = 8.2' (2500 mm)
13.4900.040.12	1.57" x 1.57" x 0.078" (40 x 40 x 2.0 mm)	L = 16.4' (5000 mm)
316		
OUTDOOR		
14.4900.040.12	1.57" x 1.57" x 0.078" (40 x 40 x 2.0 mm)	L = 16.4' (5000 mm)

FIGURE 6—HANDRAIL PROFILES

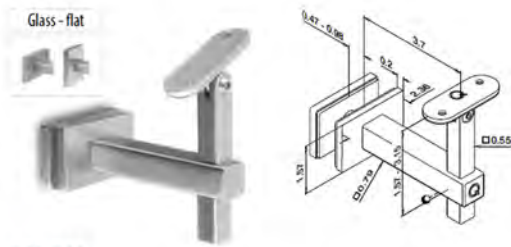

MOD 4155

304				
INDOOR				
13.4155.000.12	Q-32	1-1/2" (38.1 mm)	OS-113 # 224	2
316				
OUTDOOR				
14.4155.000.12	Q-32	1-1/2" (38.1 mm)	OS-113 # 224	2



MOD 4155

304				
INDOOR	Q	Ø		
13.4155.038.12	Q-32	1-1/2" (38.1 mm)	OS-111 # 225	2
316				
OUTDOOR	Q	Ø		
14.4155.038.12	Q-32	1-1/2" (38.1 mm)	OS-111 # 225	2

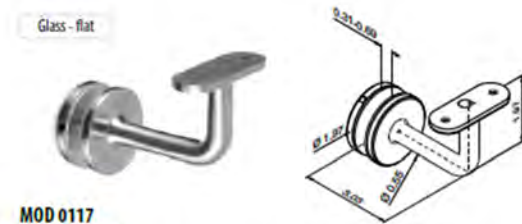

MOD 0117

304				
INDOOR	Q	Ø		
13.0117.000.12	Q-32	1-1/2" (38.1 mm)	OS-113 # 224	2
316				
OUTDOOR	Q	Ø		
14.0117.000.12	Q-32	1-1/2" (38.1 mm)	OS-113 # 224	2



MOD 0117

304				
INDOOR	Q	Ø		
13.0117.038.12	Q-32	1-1/2" (38.1 mm)	OS-111 # 225	2
13.0117.048.12	Q-32	1.9" (48.3 mm)	OS-111 # 225	2
316				
OUTDOOR	Q	Ø		
14.0117.038.12	Q-32	1-1/2" (38.1 mm)	OS-111 # 225	2
14.0117.048.12	Q-32	1.9" (48.3 mm)	OS-111 # 225	2



MOD 9350

304				
INDOOR	Q	Ø		
13.9350.038.12	Q-32	1-1/2" (38.1 mm)	OS-125 # 224	2

FIGURE 7—HANDRAIL BRACKETS



MOD 0150

316				
OUTDOOR				
Q	Ø	Key	Box	
14.0150.000.12	Q-32	05-111	224	2



MOD 0150

304					
INDOOR					
Q	Ø	Key	Box		
13.0150.038.12	Q-32	1-1/2" (38.1 mm)	05-111	225	2



MOD 0155

304				
INDOOR				
Q	Ø	Key	Box	
13.0155.000.12	Q-32	05-111	224	2

316				
OUTDOOR				
Q	Ø	Key	Box	
14.0155.000.12	Q-32	05-111	224	2



MOD 0155

304					
INDOOR					
Q	Ø	Key	Box		
13.0155.038.12	Q-32	1-1/2" (38.1 mm)	05-111	225	2
13.0155.048.12	Q-32	1.9" (48.3 mm)	05-111	225	2

316					
OUTDOOR					
Q	Ø	Key	Box		
14.0155.038.12	Q-32	1-1/2" (38.1 mm)	05-111	225	2
14.0155.048.12	Q-32	1.9" (48.3 mm)	05-111	225	2

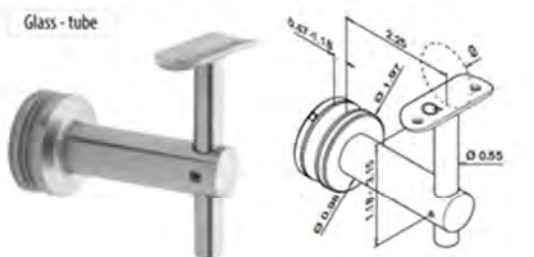
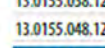

MOD 0151

304					
INDOOR					
Q	Ø	Key	Box		
13.0151.038.12	Q-32	1-1/2" (38.1 mm)	05-111	225	2

316					
OUTDOOR					
Q	Ø	Key	Box		
14.0151.038.12	Q-32	1-1/2" (38.1 mm)	05-111	225	2



MOD 0156

304					
INDOOR					
Q	Ø	Key	Box		
13.0156.038.12	Q-32	1-1/2" (38.1 mm)	05-111	225	2

316					
OUTDOOR					
Q	Ø	Key	Box		
14.0156.038.12	Q-32	1-1/2" (38.1 mm)	05-111	225	2

FIGURE 7 (CONT'D)—HANDRAIL BRACKETS









E.G.SLIM				
	SLIM TOP MOUNT (MOD 6904)	SLIM FASCIA MOUNT (MOD 6905)		
E.G.SMART				
	SMART TOP MOUNT (MOD 6930)	SMART FASCIA MOUNT (MOD 6931)	SMART TOP MOUNT - F Profile (MOD 6932)	SMART FASCIA MOUNT - Y Profile (MOD 6933)
E.G.PRIME				
	PRIME TOP MOUNT (MOD 6960)	PRIME FASCIA MOUNT (MOD 6961)	PRIME FASCIA MOUNT - Y Profile (MOD 6963)	PRIME TOP MOUNT - F Profile (MOD 6962)
E.G.MAX				
	MAX TOP MOUNT (MOD 6926)	MAX FASCIA MOUNT (MOD 6935)		

FIGURE 8—BASE SHOE PROFILES

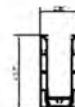
DIVISION: 05 00 00—METALS**Section: 05 52 00—Metal Railings****Section: 05 73 13—Glazed Decorative Metal Railings****DIVISION: 08 00 00—OPENINGS****Section: 08 81 00—Glass Glazing****Section: 08 88 00—Special Function Glazing****REPORT HOLDER:**

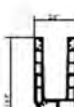
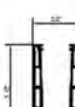
Q-RAILING USA CO.

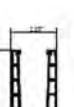
EVALUATION SUBJECT:

EASY GLASS RAILING SYSTEMS

1.0 REPORT PURPOSE AND SCOPE**Purpose:**

The purpose of this evaluation report supplement is to indicate that Easy Glass Railing Systems, described in ICC-ES evaluation report [ESR-4688](#), have also been evaluated for compliance with the codes noted below as adopted by the Los Angeles Department of Building and Safety (LADBS).

Applicable code editions:

- 2020 *City of Los Angeles Building Code* (LABC)
- 2020 *City of Los Angeles Residential Code* (LARC)

2.0 CONCLUSIONS

The Easy Glass Railing Systems, described in Sections 2.0 through 7.0 of the evaluation report [ESR-4688](#), comply with the LABC Chapter 24, and the LARC, and are subject to the conditions of use described in this supplement.

3.0 CONDITIONS OF USE

The Easy Glass Railing Systems described in this evaluation report supplement must comply with all of the following conditions:

- All applicable sections in the evaluation report [ESR-4688](#).
- The design, installation, conditions of use and identification of the Easy Glass Railing Systems are in accordance with the 2018 *International Building Code*® (IBC) provisions noted in the evaluation report [ESR-4688](#).
- The design, installation and inspection are in accordance with additional requirements of LABC Chapters 16 and 17, as applicable.
- Under the LARC, an engineered design in accordance with LARC Section R301.1.3 must be submitted.

This supplement expires concurrently with the evaluation report, issued June 2021.

DIVISION: 05 00 00—METALS

Section: 05 52 00—Metal Railings

Section: 05 73 13—Glazed Decorative Metal Railings

DIVISION: 08 00 00—OPENINGS

Section: 08 81 00—Glass Glazing

Section: 08 88 00—Special Function Glazing

REPORT HOLDER:

Q-RAILING USA CO.

EVALUATION SUBJECT:

EASY GLASS RAILING SYSTEMS

1.0 REPORT PURPOSE AND SCOPE**Purpose:**

The purpose of this evaluation report supplement is to indicate that the Easy Glass Railing Systems, described in ICC-ES evaluation report ESR-4688, have also been evaluated for compliance with the codes noted below.

Applicable code editions:

- 2019 *California Building Code* (CBC)

For evaluation of applicable chapters adopted by the California Office of Statewide Health Planning and Development (OSHPD) and Division of State Architect (DSA), see Sections 2.1.1 and 2.1.2 below.

- 2019 *California Residential Code* (CRC)

2.0 CONCLUSIONS**2.1 CBC:**

The Easy Glass Railing Systems, described in Sections 2.0 through 7.0 of the evaluation report ESR-4688, comply with CBC Chapters 10 and 24, provided the design and installation are in accordance with the 2018 *International Building Code*® (IBC) provisions noted in the evaluation report and the additional requirements of CBC Chapters 10, 16 and 24, as applicable.

2.1.1 OSHPD: The applicable OSHPD Sections of the CBC are beyond the scope of this supplement.

2.1.2 DSA: The applicable DSA Sections of the CBC are beyond the scope of this supplement.

2.2 CRC:

The Easy Glass Railing Systems, described in Sections 2.0 through 7.0 of the evaluation report ESR-4688, comply with CRC Chapter 3, provided the design and installation are in accordance with the 2018 *International Residential Code*® (IRC) provisions noted in the evaluation report.

This supplement expires concurrently with the evaluation report, issued June 2021.

DIVISION: 05 00 00—METALS

Section: 05 52 00—Metal Railings

Section: 05 73 13—Glazed Decorative Metal Railings

DIVISION: 08 00 00—OPENINGS

Section: 08 81 00—Glass Glazing

Section: 08 88 00—Special Function Glazing

REPORT HOLDER:

Q-RAILING USA CO.

EVALUATION SUBJECT:

EASY GLASS RAILING SYSTEMS

1.0 REPORT PURPOSE AND SCOPE**Purpose:**

The purpose of this evaluation report supplement is to indicate that the Easy Glass Railing Systems, described in ICC-ES evaluation report ESR-4688, have also been evaluated for compliance with the codes noted below.

Applicable code editions:

- 2020 *Florida Building Code—Building*
- 2020 *Florida Building Code—Residential*

2.0 CONCLUSIONS

The Easy Glass Railing Systems, described in Sections 2.0 through 7.0 of ICC-ES evaluation report ESR-4688, comply with the *Florida Building Code—Building* and the *Florida Building Code—Residential*. The design requirements must be determined in accordance with the *Florida Building Code—Building* or the *Florida Building Code—Residential*, as applicable. The installation requirements noted in ICC-ES evaluation report ESR-4688 for the 2018 *International Building Code*® meet the requirements of the *Florida Building Code—Building* or the *Florida Building Code—Residential*, as applicable.

Use of the Easy Glass Railing Systems for compliance with the High-Velocity Hurricane Zone provisions of the *Florida Building Code—Building* or the *Florida Building Code—Residential* has not been evaluated and is outside the scope of this supplemental report.

For products falling under Florida Rule 61G20-3, verification that the report holder's quality assurance program is audited by a quality assurance entity approved by the Florida Building Commission for the type of inspections being conducted is the responsibility of an approved validation entity (or the code official when the report holder does not possess an approval by the Commission).

This supplement expires concurrently with the evaluation report, issued June 2021.