

# Server Provisioning and Lifecycle Management

Accelerate 5G rollouts with ATOM BLM (BareMetal Server Lifecycle Management)

*The process of readying a server for production generally involves numerous tasks, which, if done manually, adds to the communications service providers' (CSP) time to market and spikes operational expense. Even in the smallest environments, the task of server provisioning is never really "complete"— as business demands and technical changes often require administrators to re-configure settings and roles, driving further management complexity. On-going server maintenance activities, including health monitoring, firmware upgrades, and decommissioning, are also cumbersome.*

To anticipate the continuously changing and evolving network needs, one must shift toward virtualization and automated multi-vendor network support, as past legacy systems cannot provide the needed scale and speed required to deploy new access services such as 5G. Therefore, CSPs must build their IT infrastructure with agility, flexibility, and ability in mind. These capabilities will support needed scale for on-demand enterprise needs for data, video, and rich-media services. Shifting to virtual and cloud-native network functions (VNFs/CNFs) also allows network operators to reduce costs and improve business agility.

Since cloudification and virtualization of networks facilitates the flexibility of BYOD (Bring your own device), CSPs are no longer locked into a single vendor environment which allows for a best-of-breed approach to network design and the flexibility of choosing high-performance servers, switches, storage, and cloud solutions.

This approach undoubtedly brings advantages in terms of cost and flexibility to choose what is best for the network. Yet, there can be a potential downside to this model in increased management complexity and lifecycle management. Specifically, managing tens of thousands of servers, switches, and storage appliances in different geographical locations, involving different vendor and operating system types, can pressure operational expense levels and require incremental training.

## Key Considerations for ATOM BLM

CSPs wanting to implement 5G service delivery should consider the following requirements for network extensibility and scalability to support every enterprise, user, device, and application, anywhere in the world:



### Automatic server discovery

Instead of manual data entry by regional management teams, CSPs can remotely and centrally discover every server in their network using standards-based Redfish APIs for maximum efficiency. ATOM supports DELL and SuperMicro server platforms with the flexibility to add new servers supporting Redfish protocols.



### AI/ML powered server management

Manage onboarded servers and monitor their health dynamically with quick feedback and resolution suggestions with the help of ATOM's AI/ML capabilities. Sensing deviation ATOM can send an alert over email, slack, or a user-preferred communication channel and offer suggestions based on SLA compliance.



### Intelligent hardware provisioning

Fueled by AI/ML, ATOM uses predictive analysis to schedule tasks by estimating accurate completion time for various actions – update firmware versions, BIOS, BMC, etc. This intelligence will avoid idle time waiting for operator input or procurement of hardware resources to realize a Just-in-Time rollout.



### Centralized control and flexibility

Processes break down if users can't access data and applications. To address this, ATOM facilitates various actions on multiple servers with 100% visibility to each task within a single management console, thus avoiding data isolation and errors.



### Automated monitoring and troubleshooting

ATOM can define the thresholds as per SLA to trigger alerts about outliers such as CPU spikes and memory/disk usage. Multiple tests, including ping, VIM NIC, can be initiated to check connectivity and receive quick notification in the preferred Communication channel in case of deviation, reducing the mean time to repair (MTTR).

## Accelerating Server Provisioning

Servers can introduce complex deployment steps with multiple dependencies, primarily distributed ones. Manual server provisioning can also be incredibly tedious and error-prone.

Server deployment steps in the past:

1. Registering the newly provisioned server in the IT Service Management (ITSM) tool
2. Initiating approval processes before provisioning the server
3. Notifying the user of their new server address and credentials
4. Setting reminders to check when it's time to shut down the server so that it is utilized efficiently
5. Regular server lifecycle management tasks – updating the server memory and CPU cores when the load increases, monitoring temperature, health, and other utilization parameters, creating trouble tickets in case of any abnormal conditions, and more

These steps are just the tip of the iceberg because they solely focus on deployment. However, to keep the server up and running, one must manage the entire lifecycle. In addition to deployment, the operator also has to manage upgrades, failures, configuration changes, scaling, and SLA Compliance. Many companies are adopting hybrid models to choose the best network and infrastructure management scenario – and the process is quickly becoming cumbersome with all the different vendors.

Anuta Networks ATOM BLM comprehends the need to support multi-vendor servers, storage, and networking hardware with consistent functionality across each task -discovery, inventory, configuration, monitoring, control, diagnosis, and upgrade. The list also includes interworking with specific vendor management servers and functions in different configurations with total transparency through standardized protocols, adaptors, and APIs

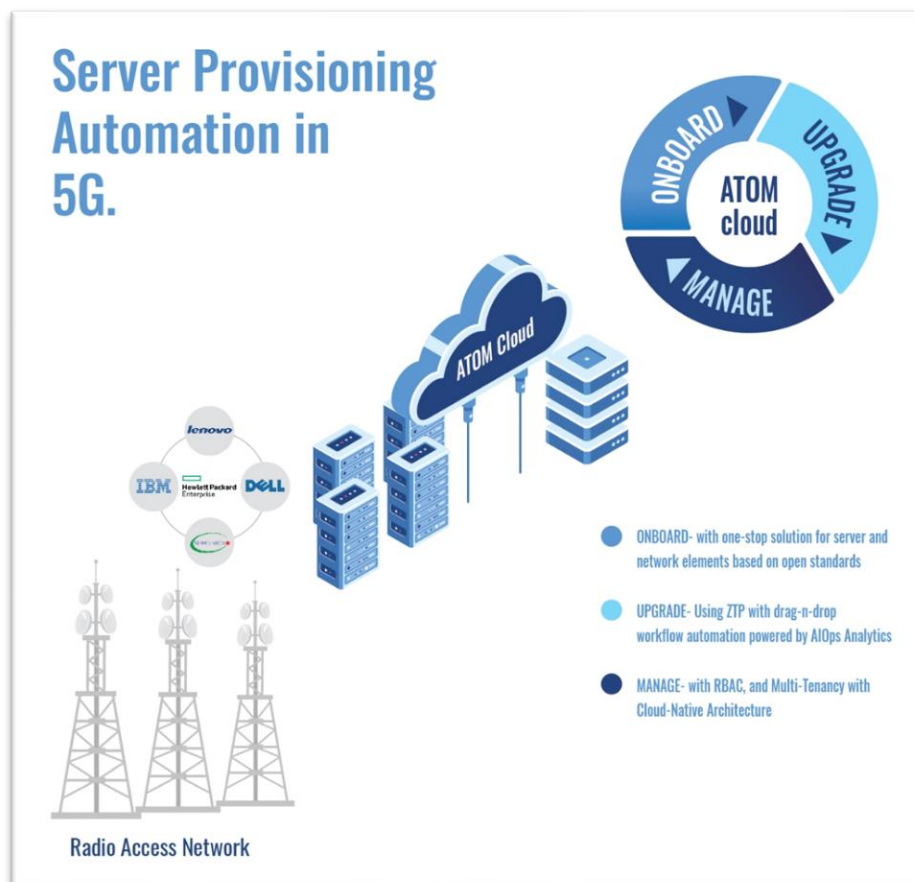

## Server Management at Scale

A network built to provide a fixed level of service capacity will occasionally be overwhelmed by peak loads that occur on rare occasions. This condition results in poor utilization of capital equipment and unnecessary energy consumption. Servers also require real-time scaling to accommodate for burst performance. However, if the number of servers is high, managing them will prove exorbitantly expensive.

Recalling the earlier example, one server single-handedly cannot support thousands of devices; there is typically a need to deploy countless servers in geographically distributed regions quickly. This situation raises the issue of scalability with multiple vendors and adds to the management complexity in validating metrics, implementing correct configurations, and adhering to SLAs. To address the issue, CSPs require ease of provisioning and orchestration. ATOM BLM can deliver!

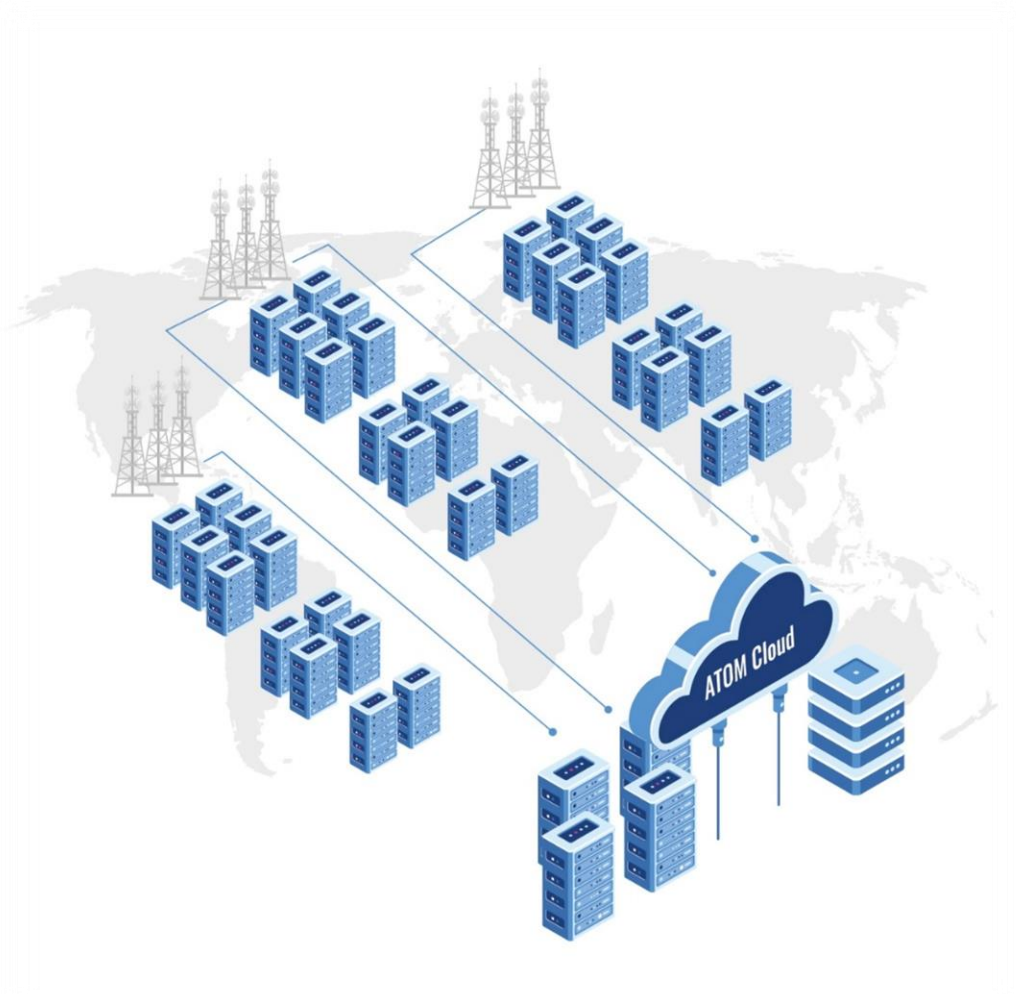

*(Massively Scalable ATOM Cloud Architecture)*

## Zero Touch Provisioning Orchestration

A core feature of ATOM is ‘zero-touch provisioning’ (ZTPO) which can deliver on the promise of horizontal scalability. ZTPO involves setting up devices and integrating them into a single harmonious working environment while eliminating manual steps and the possibility of human errors. ATOM offers a true multi-vendor ZTPO capability through its DHCP-based approach to automate steps such as deploying Day-0 configuration templates, updating software images, deploying patches, and fixing bugs with simple visual steps.

Additionally, ATOM makes these often-cumbersome processes simpler and faster by empowering operators to provision from anywhere, leverage massive scalability with microservices, containerized architecture, and customize deployment based on workload requirements.

### How does ATOM BLM implement ZTPO?

1. ATOM uses provisioning as a building block that takes input from the previous building block (Trigger PXE boot).

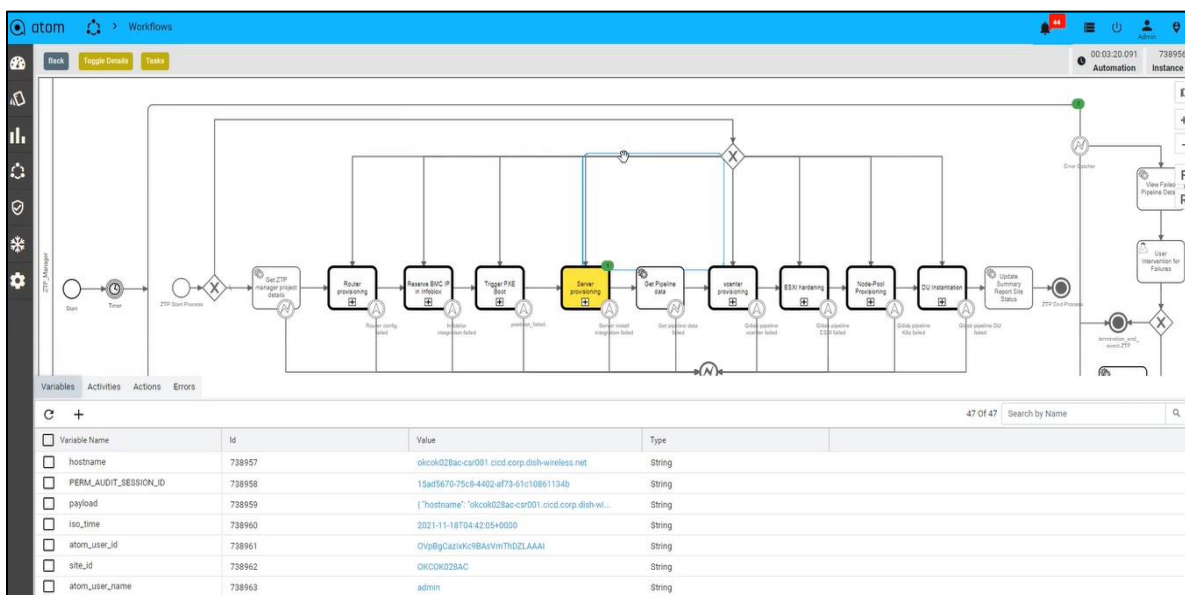

2. The server provisioning block comprises a collection of sub-blocks, each stitched together as a low code workflow object to achieve a specific outcome.

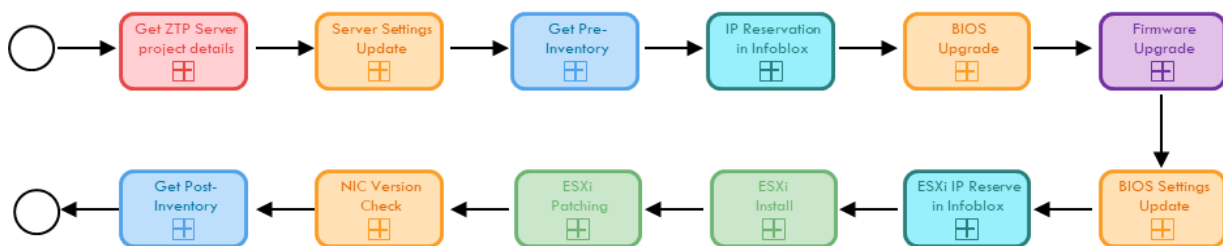

3. ATOM provides granular visibility into the status and health of each of these tasks for the ease of administration and management.

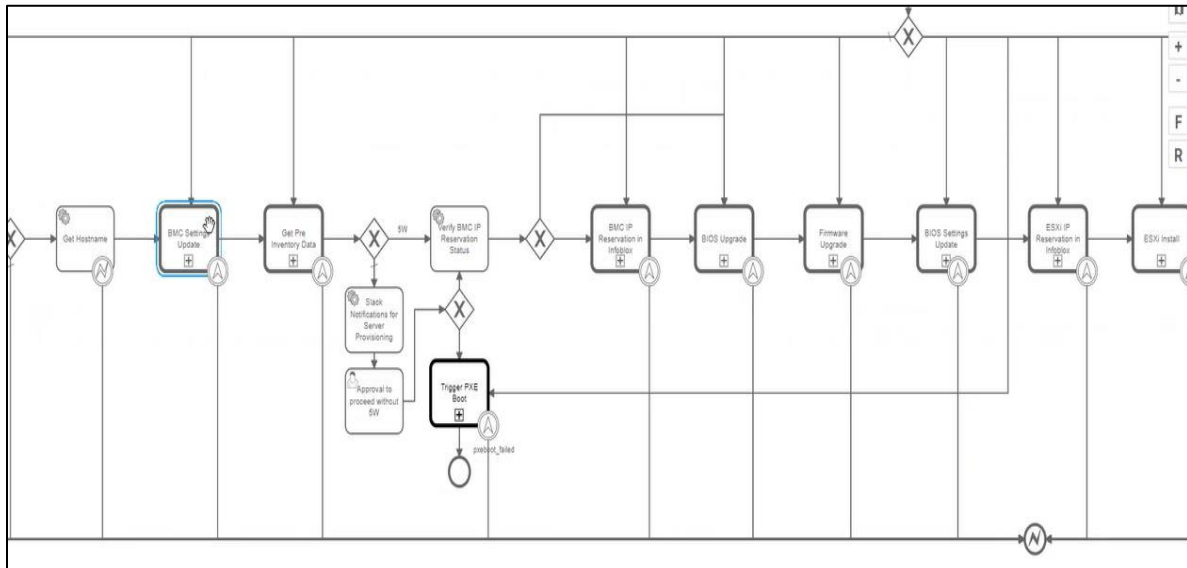

Once the workflow concludes, the server is provisioned. As opposed to taking 24 hours in a manual process, the entire workflow takes 20-30 mins to execute the whole process, including the deployment that also involves various computing and storage requirements. Additionally, user interventions can also be built within each of these tasks where a JIRA ticket can be raised for boot approval.

### Centralized Console

Clearly, with multi-vendor servers being hosted in hundreds of private and public locations around the world, CSPs require a single-pane-of-glass interface with high-fidelity visibility into the health of each server.

ATOM operates from the cloud and delivers all control and capabilities through a single unified framework, eliminating the need for stand-alone deployments. ATOM's customizable dashboards enable CSPs to gain complete transparency into real-time updates on how many sites are completed, servers in progress, or trouble spots. ATOM also displays where a particular server is located with accuracy, its age and shows trend analysis based on past data.

Backed by its cloud-native architecture, ATOM has achieved massive scalability by successfully provisioning as many as 900 servers in one hour! The secret lies in ATOM's ability to leverage the power of automation for lifecycle management— all from a single interface while collecting millions of performance metrics every second!

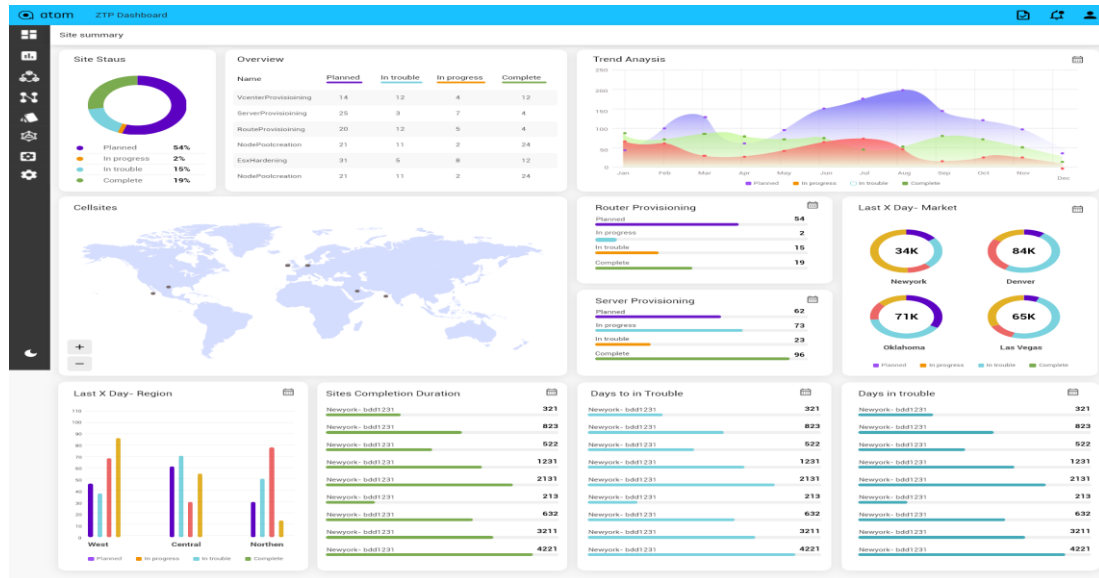

*(Centralized reporting in case of server provisioning)*

## Conclusion

CSPs building 5G networks and innovative services require CNF and VNFs installed on servers to achieve agility and economies of scale. Hence, server lifecycle automation is critical to ensure performance, availability, and efficiency. But it is impractical for operators to use large numbers of discrete suppliers and invest in extensive, custom integration work. Anuta Networks ATOM delivers an integrated server, network orchestration, and lifecycle management capability that not only saves time but provides greater visibility and control over complex and massive scale multi-vendor architectures and traffic flows. ATOM BLM accelerates network transformation with cost savings on bandwidth, network management, IT staff, security, and scalability to support disruptive technologies and connectivity platforms such as 5G. With the added benefits of AI and ML-based techniques, ATOM aims to make any server deployment smarter and auto-managed to increase productivity and 5 9's reliability.

## Additional Resources

[Video-on-demand](#) on Server Provisioning and Lifecycle management

To learn how Anuta Network's ATOM Workflow Automation and ZTP can help you simplify network provisioning, contact us at <https://www.anutanetworks.com>